

NÁBYTKOVÉ KOVANIE

2018





KNK Plus výrobné družstvo je výrobca a dodávateľ nábytkového a bytového kovania s tradíciou výroby od roku 1956.

KNK Plus, production cooperative, is a producer and distributor of furniture fittings with tradition of producing spanning from 1956.

TRADE BANSKÁ BYSTRICA / TRADE BANSKÁ BYSTRICA

- veľkoobchod s nábytkovým kovaním / wholesale store

adresa: Majerská cesta 73, Banská Bystrica

email: trade@knkplus.sk

tel: +421 48 411 51 32



NÁHRADNÉ PLNENIE

Každá firma, ktorá zamestnáva viac ako 20 zamestnancov je povinná, **podľa Zákona č. 5/2004 o službách zamestnanosti**, zamestnávať 3,2%-ný podiel zdravotne postihnutých občanov z celkového počtu svojich zamestnancov, inak platí štátu povinné odvody.

Možnosťou, ako ušetriť vlastné finančné prostriedky, je využiť náhradné plnenie a odobrať výrobky alebo služby **od chránenej dielne**, ktorá zamestnáva ľudí so zdravotným postihnutím - zadanie a realizácia zákazky podľa §64a zákona, zákon č. 05/2004 o službách zamestnanosti.

KNK PLUS v.d. chránená dielňa môže poskytnúť náhradné plnenie za:

- baliacu činnosť
- výrobu a predaj nábytkového kovania
- montáž nábytku z dielcov
- výroba kovových výrobkov





1 Bratislava

OD Slimák, Hálková 1
tel.: +421 2 44452938
email: predajnaba@knkplus.sk

2 Banská Bystrica

Nám. Slobody č.5
tel.: +421 48 4715952
email: predajnabb@knkplus.sk

3 Lučenec

Zvolenská cesta č.10
tel.: +421 917 938 631
email: predajnalc@knkplus.sk

4 Prešov

Levočská č. 2
tel.: +421 51 7710760
email: predajnapo@knkplus.sk

NÁBYTKOVÉ KOVANIE

PRE VÝROBCOV ČALÚNENÉHO NÁBYTKU

v1.0/2017

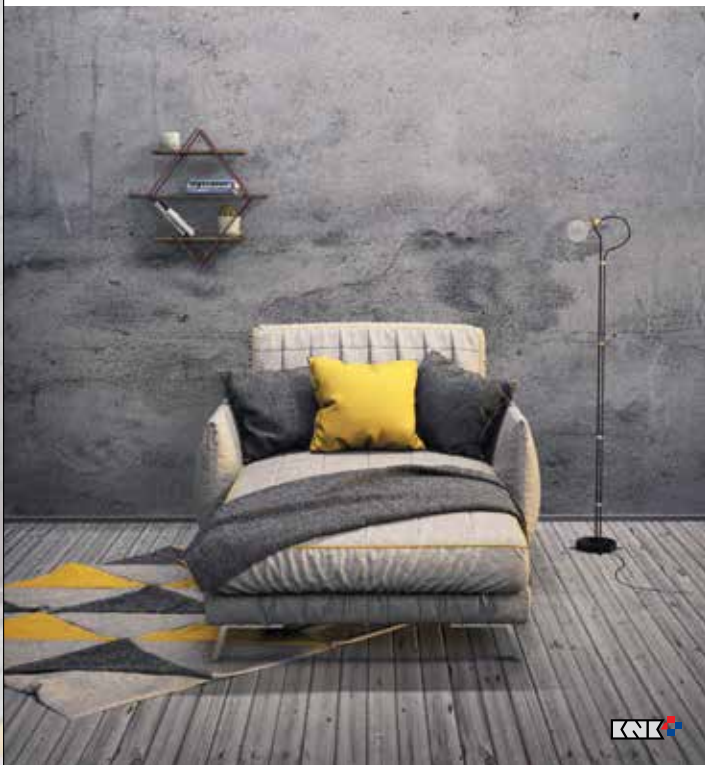







KATALÓG NÁBYTKOVÉHO KOVANIA PRE VÝROBCOV ČALÚNENÉHO NÁBYTKU

KNK PLUS vám predstavuje svoj nový katalóg kovania pre výrobcov čalúneného nábytku. V katalógu nájdete náš kompletný sortiment od nôh, podnoží a klzákov, cez kolieska, kovania pre podrúčky a opierky až po výklopné mechanizmy pre postele a sedačky, rozkladacie mechanizmy a množstvo doplnkového tovaru.

V prípade záujmu o tlačенú verziu katalógu prosím kontaktujte nášho obchodného zástupcu.

Elektronická verzia katalógu je prístupná na stiahnutie na našej internetovej stránke www.knkplus.sk v sekcii *Katalógy/Návody*.

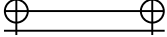
Symbols / Symbols

	Priemer / Diameter
	Dĺžka / Length
	Šírka / Width
	Výška / Height
	Rozteč / Hole spacing
	Hrúbka materiálu / Thickness
*	Voliteľný rozmer / Alternative measurement

Materiál / Material

Zn	Zinok / Zinc
S	Oceľ / Steel
I	Inox (nerez) / Stainless steel
Al	Hliník / Aluminium
B	Mosadz / Brass
P	Plast / Plastic
R	Guma / Rubber
CRM	Keramika / Ceramics
KR	Swarovski krištál / Swarovski crystal

W











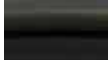

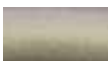
Drevo / Wood

smrek	Smrek / Spruce
buk	Buk / Beech
dub	Dub / Oak
borovica	Borovica / Pine
čerešňa	Čerešňa / Cherry
jelša	Jelša / Alder
orech	Orech / Walnut
mahagón	Mahagón / Mahogany

Povrchové úpravy / Finishing

Galvanické / Galvanic

G

Cr	
cCr	
Crn	
Ni	
Nim	
Ms	
pat	
Pat na Ms	
Pat na medi	
Bronz	
Te	
li	
Zn	
antracit	

Chróm / Chrome

Čierny chróm / Black chrome

Chróm matný / Chrome mat

Nikel / Nickel

Nikel matný / Nickel mat

Mosadz / Brass

Patina / Antique

Patina na mosadzi / Antique brass

Patina na medi / Antique copper

Bronz / Bronze

Imitácia cínu / Tin effect

Imitácia inox (nerez) / Stainless steel effect

Zinok / Zinc

Antracit / Antracit

C

biela

Biela / White

hnedá

Hnedá / Brown

čierna

Čierna / Black

šedá

Šedá / Gray

lak

Lak / Lacquer

*

Voliteľná farba / Alternative color

Vysvetlivky Hettich

SiSy Silent System

Zatváranie s integrovaným tlmením

P20 Push to open

Dotykové otváranie

P20 Si Push to open Silent

Dotyk. otváranie s tlmením pri zatváraní



KOVOVÉ ÚCHYTKY

6-21

METAL HANDLES



PLASTOVÉ A DREVENÉ ÚCHYTKY

22-27

PLASTIC AND WOODEN HANDLES

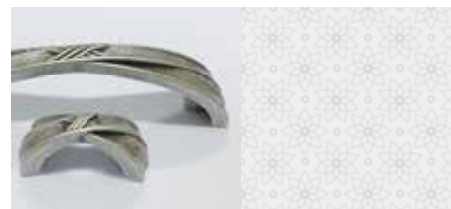

RUSTIKÁLNE ÚCHYTKY

28-39

RUSTIC HANDLES



KNOPKY

40-47

KNOBS



VEŠIAKY

48-57

HANGERS



DVEROVÉ KOVANIE

58-71

DOOR FITTINGS



KLZÁKY A NOHY

72-83

GLIDERS AND LEGS



STOLOVÉ KOVANIE

84-89

TABLE FITTINGS



KOLIESKA

90-95

WHEELS



KONŠTRUKČNÉ PRVKY

96-111

FITTING ELEMENTS



ZÁVESY, PÁNTY A ZÁMKY

112-125

HINGES AND LOCKS



VÝKLOPNÉ SYSTÉMY

126-129

LIFT SYSTEMS



ZÁSUVKY

130-143

DRAWER SYSTEMS



POSUVNÉ SYSTÉMY

144-153

SLIDING SYSTEMS



DRÔTENÝ PROGRAM

154-159

KITCHEN PARTS



HLINÍKOVÉ RÁMIKY A PROFILY

160-163

ALUMINIUM FRAMES



LED OSVETLENIE

164-171

LED LIGHTS



TESÁRSKE KOVANIE

172-175

CARPENTRY FITTINGS

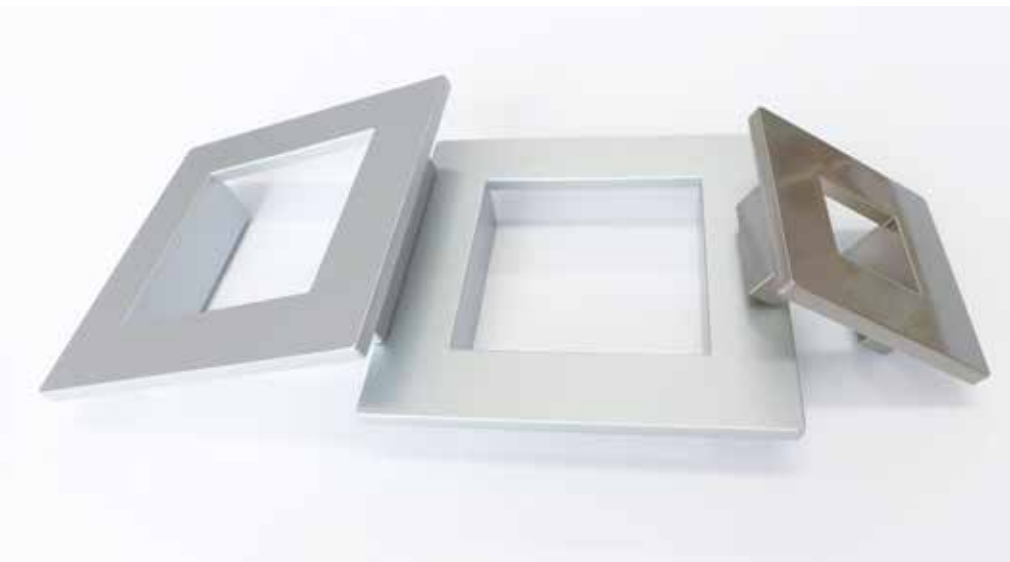

KOVOVÉ ÚCHYTKY
METAL HANDLES

MAXIM



Artik. číslo	Název	Materiál	Povrchová úprava	—	!	—	⊕	⊕
22 01 x xx	MAXIM 96	S	Cr, Crm, Nim	140	12	35	96	
22 02 x xx	MAXIM 128	S	Cr, Crm, Nim	172	12	35	128	
22 01 x xx	MAXIM 160	S	Cr, Crm, Nim	204	12	35	160	
22 01 x xx	MAXIM 192	S	Cr, Crm, Nim	236	12	35	192	
22 03 x xx	MAXIM 224	S	Cr, Crm, Nim	268	12	35	224	
22 04 x xx	MAXIM 320	S	Cr, Crm, Nim	364	12	35	320	
22 04 x xx	MAXIM 384	S	Cr, Crm, Nim	428	12	35	384	
22 04 x xx	MAXIM 432	S	Cr, Crm, Nim	476	12	35	432	
22 04 x xx	MAXIM 576	S	Cr, Crm, Nim	620	12	35	576	
22 04 x xx	MAXIM 608	S	Cr, Crm, Nim	652	12	35	608	
*	MAXIM	S	Cr, Crm, Nim	*	12	35	*	

MARIK



Artik. číslo	Název	Materiál	Povrchová úprava	—	!	—	⊕	⊕
22 05 x xx	MARIK 64	S	Cr, Crm, Nim	108	10	33	64	
22 06 x xx	MARIK 96	S	Cr, Crm, Nim	140	10	33	96	
22 07 x xx	MARIK 128	S	Cr, Crm, Nim	172	10	33	128	
22 08 x xx	MARIK 160	S	Cr, Crm, Nim	204	10	33	160	
22 08 x xx	MARIK 224	S	Cr, Crm, Nim	268	10	33	224	
22 09 x xx	MARIK 320	S	Cr, Crm, Nim	364	10	33	320	
22 09 x xx	MARIK 384	S	Cr, Crm, Nim	428	10	33	384	
*	MARIK	S	Cr, Crm, Nim	*	10	33	*	

MAXIM H



Artik. číslo	Název	Materiál	Povrchová úprava	—	!	—	⊕	⊕
22 01 0 01	MAXIM H 96	S	li	150	12	35	96	
22 01 0 02	MAXIM H 128	S	li	180	12	35	128	
22 01 0 03	MAXIM H 160	S	li	200	12	35	160	
22 01 0 04	MAXIM H 224	S	li	280	12	35	224	
22 01 0 05	MAXIM H 320	S	li	400	12	35	320	
22 01 0 06	MAXIM H 432	S	li	500	12	35	432	
22 01 0 07	MAXIM H 544	S	li	600	12	35	544	
22 01 0 08	MAXIM H 608	S	li	712	12	35	608	
22 01 0 09	MAXIM H 736	S	li	850	12	35	736	

DIANA



Artik. číslo	Název	Materiál	Povrchová úprava	—	!	—	⊕	⊕
51 37 9 01	DIANA 96	S	li	137	14	33	96	
51 38 9 01	DIANA 128	S	li	168	14	33	128	
51 39 9 01	DIANA 160	S	li	200	14	33	160	
51 40 9 01	DIANA 224	S	li	264	14	33	224	
51 41 9 01	DIANA 320	S	li	360	14	33	320	
51 42 9 01	DIANA 432	S	li	473	14	33	432	
51 43 9 01	DIANA 544	S	li	584	14	33	544	
51 44 9 01	DIANA 608	S	li	648	14	33	608	
51 45 9 01	DIANA 736	S	li	776	14	33	736	

ALENA



Artik. číslo	Název	Materiál	Povrchová úprava	—	!	—	⊕	⊕
55 90 9 01	ALENA 128	S	li	135	12	30	128	
55 91 9 01	ALENA 160	S	li	168	12	30	160	
55 92 9 01	ALENA 192	S	li	200	12	30	192	
55 93 9 01	ALENA 224	S	li	232	12	30	224	
55 94 9 01	ALENA 320	S	li	328	12	30	320	
55 95 9 01	ALENA 432	S	li	440	12	30	432	
55 96 9 01	ALENA 544	S	li	552	12	30	544	
55 97 9 01	ALENA 608	S	li	620	12	30	608	
55 98 9 01	ALENA 736	S	li	745	12	30	736	

MONIKA



Artik. číslo	Název	Materiál	Povrchová úprava	—	!	—	⊕	⊕
25 15 x 00	MONIKA 96	Zn	Cr, Crm, Nim, cCr	130	9	28	96	
25 10 x 00	MONIKA 128	Zn	Cr, Crm, Nim, cCr	162	9	28	128	
25 1x x xx	MONIKA 160	Zn	Cr, Crm, Nim, cCr, li, bronz	198	9	28	160	
25 16 x 00	MONIKA 192	Zn	Cr, Crm, Nim, cCr, li, bronz	230	9	28	192	
25 12 x 00	MONIKA 224	Zn	Cr, Crm, Nim, cCr	262	9	28	224	
25 13 x 00	MONIKA 256	Zn	Cr, Crm, Nim, cCr	294	9	28	256	
25 14 x 00	MONIKA 320	Zn	Cr, Crm, Nim, cCr	358	9	28	320	

KORA



Artik. číslo	Názov	Materiál	Povrchová úprava	▬	!	┌	⊕
51 00 8 xx	KORA 128	AL	Cr, biela	142	25	30	128
51 01 8 xx	KORA 160	AL	Cr, biela	174	25	30	160
51 02 8 xx	KORA 192	AL	Cr, biela	206	25	30	192
51 03 8 xx	KORA 224	AL	Cr, biela	238	25	30	224
51 04 8 xx	KORA 320	AL	Cr, biela	334	25	30	320
51 05 8 xx	KORA 432	AL	Cr, biela	446	25	30	432
51 06 8 xx	KORA 544	AL	Cr, biela	560	25	30	544
51 07 8 xx	KORA 736	AL	Cr, biela	751	25	30	736

PORTA



Artik. číslo	Názov	Materiál	Povrchová úprava	▬	!	┌	⊕
55 80 8 xx	PORTA 128	AL	Cr, Crm, biela, čierna, li	136	16	36	128
55 81 8 xx	PORTA 160	AL	Cr, Crm, biela, čierna, li	168	16	36	160
55 82 8 xx	PORTA 192	AL	Cr, Crm, biela, čierna, li	200	16	36	192
55 83 8 xx	PORTA 224	AL	Cr, Crm, biela, čierna, li	232	16	36	224
55 88 8 xx	PORTA 320	AL	Cr, Crm, biela, čierna, li	328	16	36	320
55 84 8 xx	PORTA 432	AL	Cr, Crm, biela, čierna, li	440	16	36	432
55 88 8 xx	PORTA 480	AL	Cr, Crm, biela, čierna, li	488	16	36	480
55 87 8 xx	PORTA 532	AL	Cr, Crm, biela, čierna, li	540	16	36	532
55 85 8 xx	PORTA 736	AL	Cr, Crm, biela, čierna, li	744	16	36	736
55 88 8 xx	PORTA 800	AL	Cr, Crm, biela, čierna, li	808	16	36	800
*	PORTA	AL	Cr, biela, čierna	*	16	36	*
55 89 8 9x	PORTO	AL	Cr, čierna, biela	20	16	36	-

MONA



Artik. číslo	Názov	Materiál	Povrchová úprava	▬	!	┌	⊕
51 57 8 xx	MONA 128	AL	Cr, biela, čierna	155	8	30	128
51 58 8 xx	MONA 160	AL	Cr, biela, čierna	188	8	30	160
51 59 8 xx	MONA 192	AL	Cr, biela, čierna	229	8	30	192
51 61 8 xx	MONA 320	AL	Cr, biela, čierna	348	8	30	320
51 60 8 xx	MONA 432	AL	Cr, biela, čierna	460	8	30	432
51 62 8 xx	MONA 480	AL	Cr, biela, čierna	509	8	30	480
51 64 8 xx	MONA 832	AL	Cr, biela, čierna	860	8	30	832

LIBRA



Artik. číslo	Názov	Materiál	Povrch. úprava	▬	!	┌	⊕
00 00 83 700	LIBRA 128	Al	Cr	146	10	32	128
00 00 82 901	LIBRA 128	Al	li	146	10	32	128
00 00 22 300	LIBRA 160	Al	Cr	178	10	32	160
00 00 22 837	LIBRA 160	Al	Cr	178	10	32	160
00 00 83 901	LIBRA 160	Al	li	178	10	32	160
00 00 84 837	LIBRA 192	Al	Cr	210	10	32	192
00 00 84 901	LIBRA 192	Al	li	210	10	32	192
00 00 25 837	LIBRA 224	Al	Cr	242	10	32	224
00 00 25 901	LIBRA 224	Al	li	242	10	32	224
00 00 23 300	LIBRA 256	Al	Cr	274	10	32	256
00 00 21 300	LIBRA 320	Al	Cr	338	10	32	320
00 00 21 700	LIBRA 320	Al	Cr	338	10	32	320
00 00 21 901	LIBRA 320	Al	li	338	10	32	320
00 00 25 300	LIBRA 400	Al	Cr	418	10	32	400
00 00 85 901	LIBRA 400	Al	li	418	10	32	400
00 00 24 837	LIBRA 416	Al	C	434	10	32	416

LORENA



Artik. číslo	Názov	Materiál	Povrchová úprava	▬	!	┌	⊕
59 10 3 00	LORENA 128/192	Zn	Cr	230	13	30	128/192
59 11 3 00	LORENA 192/256	Zn	Cr	294	13	30	192/256
59 12 3 00	LORENA 256/320	Zn	Cr	358	13	30	256/320
59 13 3 00	LORENA 384/448	Zn	Cr	486	13	30	384/448

200



Artik. číslo	Názov	Materiál	Povrchová úprava	▬	!	┌	⊕
02 24 8 xx	200-128	Zn	Cr, Ni	138	10	30	128

CRISTEN



NOVINKA

Artik. číslo	Názov	Materiál	Povrch. úprava	—	!	—	⊕
0000353x0	CRISTEN 192	Zn	Cr+Cr brúsená, Cr +biela	206	20	31	192
0000363x0	CRISTEN 320	Zn	Cr+Cr brúsená, Cr+biela	334	20	31	320
0000373x0	CRISTEN 480	Zn	Cr+Cr brúsená, Cr+biela	494	20	31	480
0000383x0	CRISTEN 672	Zn	Cr+biela	686	20	31	672

FLORIDA



NOVINKA

Artik. číslo	Názov	Materiál	Povrch. úprava	—	!	—	⊕
0000563xx	FLORIDA 160	Zn	Cr+Cr, Cr+li	170	18	34	160
0000573xx	FLORIDA 320	Zn	Cr+Cr, Cr+li	330	18	34	320

HANNAH



Artik. číslo	Názov	Materiál	Povrch. úprava	—	!	—	⊕
22 01 x 0x	HANNAH 160	Al,Zn	Cr, Crm	180	19	29	160
22 01 8 02	HANNAH 192	Al,Zn	Cr	212	19	29	192
22 01 x 0x	HANNAH 224	Al,Zn	Cr, Crm	243	19	29	224
22 0x x 0x	HANNAH 256	Al,Zn	Cr, Crm	276	19	29	256
22 0x x 0x	HANNAH 320	Al,Zn	Cr, Crm	339	19	29	320
22 0x x 0x	HANNAH 384	Al,Zn	Cr, Crm	402	19	29	384

LUNA



NOVINKA

Artik. číslo	Názov	Materiál	Povrch. úprava	—	!	—	⊕
000066xxx	LUNA 128	Zn	bronz, Cr, Crm, li	161	20	27	128

SARAH



Artik. číslo	Názov	Materiál	Povrch. úprava	—	!	—	⊕
22 00 8 01	SARAH 160	Al,Zn	Crm	218	19	29	160
22 01 3 02	SARAH 192	Al,Zn	Cr	250	19	29	192
22 0x x 0x	SARAH 224	Al,Zn	Cr,Crm	282	19	29	224
22 01 x 0x	SARAH 320	Al,Zn	Cr,Crm	348	19	29	320
22 01 x 0x	SARAH 384	Al,Zn	Cr,Crm	442	19	29	384

CHLOÉ



Artik. číslo	Názov	Materiál	Povrch. úprava	—	!	—	⊕
59 50 x 00	CHLOÉ 160	Al, Zn	Cr, Nim	225	25	30	160
59 51 3 00	CHLOÉ 192	Al, Zn	Cr	257	25	30	192
59 52 3 00	CHLOÉ 224	Al, Zn	Cr	289	25	30	224
22 00 x 0x	CHLOÉ 256	Al, Zn	Cr, Nim	321	25	30	256
59 53 x 00	CHLOÉ 320	Al, Zn	Cr, Nim	385	25	30	320
59 55 3 00	CHLOÉ 384	Al, Zn	Cr	449	25	30	384

CORINE



Artik. číslo	Názov	Materiál	Povrchová úprava	—	!	—	⊕
59 23 3 00	CORINE 96	Zn	Cr	106	10	36	96
59 24 3 00	CORINE 128	Zn	Cr	138	10	36	128
59 25 x 00	CORINE 160	Zn	Cr,Crm	170	10	36	160
59 00 0 02	CORINE 192	Zn	Cr	202	10	36	192
59 28 3 00	CORINE 320	Zn	Cr	330	10	36	320

CORINE S ADAPTÉROM



Artik. číslo	Názov	Materiál	Povrch. úprava	—	!	—	⊕
59 23 3 01	CORINE S ADAPTÉROM 96	Zn	Cr	106	10	36/21	
59 25 3 01	CORINE S ADAPTÉROM 160	Zn	Cr	170	10	36/21	
59 26 3 01	CORINE S ADAPTÉROM 192	Zn	Cr	202	10	36/21	
59 28 3 01	CORINE S ADAPTÉROM 320	Zn	Cr	330	10	36/21	

WMN 169



Artik. číslo	Název	Materiál	Povrchová úprava	☰	!	☷	⊕
53 86 x xx	WMN 169.128	Zn	Cr, Crm, li	136	25	24	128
53 87 x xx	WMN 169.160	Zn	Cr, Crm, li	168	30	24	160

NERA



Artik. číslo	Název	Materiál	Povrchová úprava	☰	!	☷	⊕
59 36 x 0x	NERA 128	Zn	Cr, Crm, Nim, li	135	31	31	128
59 47 x 0x	NERA 256	Zn	Cr, Crm, Nim, li	263	31	31	256

NICOLETTA



Artik. číslo	Název	Materiál	Povrch. úprava	☰	!	☷	⊕
22 00 x 11	NICOLETTA 160	Al	Cr, Crm	176	7	25	160
22 00 x 0x	NICOLETTA 224	Al	Cr, Crm	240	7	25	224
22 0x x 0x	NICOLETTA 320	Al	Cr, Crm	336	7	25	320
22 00 x xx	NICOLETTA 384	Al	Cr, Crm	450	7	25	384

WMN 136



Artik. číslo	Název	Materiál	Povrchová úprava	☰	!	☷	⊕
53 47 x xx	WMN 136.192	Zn	Cr, Crm, li	232	26	26	192

WMN 335



Artik. číslo	Název	Materiál	Povrch. úprava	☰	!	☷	⊕
22 0x x xx	WMN 335.320	Zn	Cr, Crm, li	328	9	28	320
22 0x x xx	WMN 335.128	Zn	Cr, Crm, li	136	9	28	128

WMN 001



Artik. číslo	Název	Materiál	Povrchová úprava	☰	!	☷	⊕
52 91 x xx	WMN 001.320	Zn	Cr, Crm, li	331	11	32	320
52 91 x xx	WMN 001.192	Zn	Cr, Crm, li	204	11	32	192
52 91 x xx	WMN 001.160	Zn	Cr, Crm, li	171	11	32	160

WMN 138



Artik. číslo	Název	Materiál	Povrchová úprava	☰	!	☷	⊕
53 49 x xx	WMN 138.128	Zn	Cr, Crm, li	190	26	28	128
53 51 x xx	WMN 138.192	Zn	Cr, Crm, li	224	28	28	192

WMN 020



Artik. číslo	Název	Materiál	Povrchová úprava	☰	!	☷	⊕
54 80 x xx	WMN 020.192	Zn	Cr, Crm, li	204	18	38	192
54 81 x xx	WMN 020.256	Zn	Cr, Crm, li	268	18	38	256

INTERIOR



NOVINKA

Artik. číslo	Název	Materiál	Povrchová úprava	☐	!	☐	⊕
22 00 0 xx	INTERIOR 96	Al	Cr, Nim	120	9	17	96
22 00 0 84	INTERIOR 128	Al	Cr	149	9	17	128

GOMERA



Artik. číslo	Název	Materiál	Povrchová úprava	☐	!	☐	⊕
02 22 8 xx	GOMERA 96	Al	Cr, C	120	15	14	96
*	GOMERA	Al	Cr, C	*	15	14	*

WMN 011

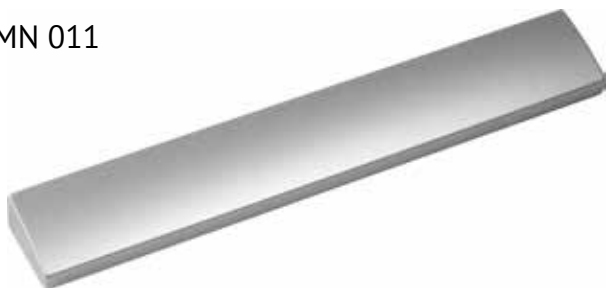

Artik. číslo	Název	Materiál	Povrchová úprava	☐	!	☐	⊕
54 95 x xx	WMN 011.128	Zn	Cr, Crm, li	146	12	22	128
54 96 x xx	WMN 011.192	Zn	Cr, Crm, li	210	12	22	192

AIDA



Artik. číslo	Název	Materiál	Povrch. úprava	☐	!	☐	⊕
59 80 9 00	AIDA 160	Zn	Cr, Crm, Nim	200	27	18	160

ADEA



Artik. číslo	Název	Materiál	Povrch. úprava	☐	!	☐	⊕
00 00 39 x0x	ADEA 128	Zn	Cr, Crm, Nim, li	147	15	30	128

FAB



Artik. číslo	Název	Materiál	Povrch. úprava	☐	!	☐	⊕
55 31 8 3x	FAB 32	AL	Cr, Nim	54	12	24	32
55 32 8 3x	FAB 64	AL	Cr, Nim	86	12	24	64
55 33 8 3x	FAB 96	AL	Cr, Nim	119	12	24	96
55 34 8 3x	FAB 128	AL	Cr, Nim	150	12	24	128
*	FAB	AL	Cr, Nim	*	12	24	*

LEMAN



Artik. číslo	Název	Materiál	Povrch. úprava	☐	!	☐	⊕
59 60 3 00	LEMAN 160	Al	Cr, Crm	200	18	20	160
59 61 3 00	LEMAN 255	Al	Cr, Crm	355	18	20	255
59 62 3 00	LEMAN 640	Al	Cr, Crm	685	18	20	640
*	LEMAN	Al	Cr	*	18	20	*

WMN 126



Artik. číslo	Název	Materiál	Povrchová úprava	☐	!	☐	⊕
53 28 x xx	WMN 126.064	Zn	Cr, Crm, li	80	18	20	64
53 29 x xx	WMN 126.096	Zn	Cr, Crm, li	112	18	20	96
53 30 x xx	WMN 126.128	Zn	Cr, Crm, li	160	26	28	128
53 31 x xx	WMN 126.9.128	Zn	Cr, Crm, li	144	18	20	128
53 32 x xx	WMN 126.192	Zn	Cr, Crm, li	208	18	20	192

WMN 006



Artik. číslo	Název	Materiál	Povrch. úprava	☐	!	☐	⊕
31 00 3 xx	WMN 006.192	Zn	Cr, Crm, li	290	30	30	192

MANTA



Artik. číslo	Název	Materiál	Povrchová úprava	☐	!	☐	⊕
55 00 x xx	MANTA 160	Zn	Cr, Nim	197	22	30	160

STELLA



Artik. číslo	Název	Materiál	Povrchová úprava	—	!	—	⊕	⊕
59 30 x 00	STELLA 224	Zn	Cr, Crm, Nim	250	8	32		224

STELLA PLUS



Artik. číslo	Název	Materiál	Povrchová úprava	—	!	—	⊕	⊕
59 32 x 00	STELLA PLUS 224	Zn	Cr, Crm, Nim	250	8	32		224

EVELIN



Artik. číslo	Název	Materiál	Povrch. úprava	—	!	—	⊕	⊕
00 1x x xx	EVELIN 128	Al	Al, Cr	157	8	30		128
00 1x x xx	EVELIN 192	Al	Al, Cr	221	8	30		192
00 1x x xx	EVELIN 256	Al	Al, Cr	285	8	30		256

MADISON



Artik. číslo	Název	Materiál	Povrch. úprava	—	!	—	⊕	⊕
00 0x x xx	MADISON 160	Zn	Cr, li	180	12	27		160
00 0x x xx	MADISON 256	Zn	Cr, li	276	12	27		256
00 0x x xx	MADISON 320	Zn	Cr, li	340	12	27		320

MARISA



Artik. číslo	Název	Materiál	Povrch. úprava	—	!	—	⊕	⊕
00 1x x xx	MARISA 192	Zn	Al, Cr	237	25	30		192
00 1x x xx	MARISA 224	Zn	Al, Cr	269	25	30		224

CHARLOTTE



Artik. číslo	Název	Materiál	Povrch. úprava	—	!	—	⊕	⊕
00 00 49 x0x	CHARLOTTE 192	Zn	Cr, li	211	10	34		192
00 00 50 x0x	CHARLOTTE 352	Zn	Cr, li	371	10	34		352

CHANTALL



Artik. číslo	Název	Materiál	Povrchová úprava	—	!	—	⊕	⊕
59 20 x 00	CHANTALL 128	Zn	Cr, Crm, Nim	192	10	31		128
59 21 x xx	CHANTALL 256	Zn	Cr, Crm, Nim	318	10	31		256

WMN 154



Artik. číslo	Název	Materiál	Povrchová úprava	—	!	—	⊕	⊕
53 67 x xx	WMN 154.160	Zn	Cr, Crm, li	225	20	26		160

WMN 153



Artik. číslo	Název	Materiál	Povrchová úprava	—	!	—	⊕	⊕
53 62 x xx	WMN 153.128	Zn	Cr, Crm, li	198	16	22		128
53 63 x xx	WMN 153.160	Zn	Cr, Crm, li	224	20	26		160

WMN 106



Artik. číslo	Název	Materiál	Povrchová úprava	—	!	—	⊕	⊕
53 23 x xx	WMN 106.160	Zn	Cr, Crm, li	178	20	30		160

STEFFI



Artik. číslo	Název	Materiál	Povrchová úprava		!		
25 56 x 00	STEFFI 96	Zn	Cr, Ms, Crm, Nim	109	13	25	96

SOFIA



Artik. číslo	Název	Materiál	Povrchová úprava		!		
25 53 x 00	SOFIA 128	Zn	Cr, Ms, Crm, Nim	152	14	25	128
25 54 x 00	SOFIA 96	Zn	Cr, Ms, Crm, Nim	114	14	25	96

INGA



Artik. číslo	Název	Materiál	Povrchová úprava		!		
22 67 x xx	INGA 128	Zn	Cr, Ms, Crm, Nim	156	10	29	128
22 68 x xx	INGA 96	Zn	Cr, Ms, Crm, Nim	126	10	28	96

PALOMA



Artik. číslo	Název	Materiál	Povrchová úprava		!		
22 75 x xx	PALOMA 128	Zn	Cr, Ms, Crm, Nim	158	13	24	128
22 73 x xx	PALOMA 16	Zn	Cr, Ms, Crm, Nim	42	12	20	16
22 74 x xx	PALOMA 96	Zn	Cr, Ms, Crm, Nim	124	11	23	96

LANTRA



Artik. číslo	Název	Materiál	Povrchová úprava		!		
55 04 x xx	LANTRA 128	Zn	Cr, Crm, Nim	135	24	27	128
55 05 x xx	LANTRA 160	Zn	Cr, Crm, Nim	167	24	27	160

LANA



Artik. číslo	Název	Materiál	Povrch. úprava		!		
-	LANA 64	Zn	li	72	35	40	64
00 00 55 901	LANA 224	Zn	li	232	35	40	224

VENICE



Artik. číslo	Název	Materiál	Povrch. úprava		!		
00 00 40 x0x	VENICE 128	Zn	Cr, li	138	30	21	128
00 00 41 x0x	VENICE 160	Zn	Cr, li	200	30	23	160
00 00 42 x0x	VENICE 192	Zn	Cr, li	232	30	23	192

GEMINI



NOVINKA

Artik. číslo	Název	Materiál	Povrchová úprava		!		
000067x0x	GEMINI 160	Zn	Cr, Nim, li	180	25	29	160
000068xxx	GEMINI 320	Zn	Cr, Nim, li, bronz	340	25	29	320

WMN 300

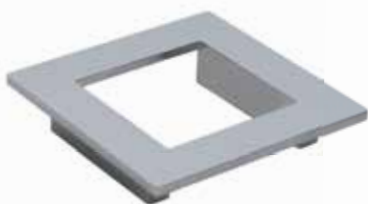

Artik. číslo	Název	Materiál	Povrchová úprava		!		
54 81 x xx	WMN 300.064	Zn	Cr, Crm, li	90	90	18	64

WMN 300



Artik. číslo	Název	Materiál	Povrchová úprava		!		
54 80 x xx	WMN 300.032	Zn	Cr, Crm, li	54	54	18	32

WMN 130



Artik. číslo	Název	Materiál	Povrchová úprava	—	!	—	⊕	⊕
53 36 x xx	WMN 130.064	Zn	Cr, Crm, li	94	12	20	64	
53 37 x xx	WMN 130.096	Zn	Cr, Crm, li	126	12	25	96	
53 38 x xx	WMN 130.128	Zn	Cr, Crm, li	166	12	27	128	
53 39 x xx	WMN 130.160	Zn	Cr, Crm, li	200	12	30	160	

WMN 132



Artik. číslo	Název	Materiál	Povrchová úprava	—	!	—	⊕	⊕
53 40 x xx	WMN 132.064	Zn	Cr, Crm, li	90	14	21	64	
53 41 x xx	WMN 132.096	Zn	Cr, Crm, li	122	14	25	96	
53 42 x xx	WMN 132.128	Zn	Cr, Crm, li	154	14	28	128	
53 43 x xx	WMN 132.160	Zn	Cr, Crm, li	186	14	28	160	

WMN 128



Artik. číslo	Název	Materiál	Povrchová úprava	—	!	—	⊕	⊕
54 37 x xx	WMN 128.064	Zn	Cr, Crm, li	88	13	22	64	
53 33 x xx	WMN 128.096	Zn	Cr, Crm, li	120	13	25	96	
53 34 x xx	WMN 128.128	Zn	Cr, Crm, li	152	13	26	128	
54 38 x xx	WMN 128.160	Zn	Cr, Crm, li	184	13	28	160	
53 35 x xx	WMN 128.192	Zn	Cr, Crm, li	216	13	28	192	

WMN 187



Artik. číslo	Název	Materiál	Povrchová úprava	—	!	—	⊕	⊕
54 82 x xx	WMN 187.096	Zn	Cr, Crm, li	108	12	22	96	
54 83 x xx	WMN 187.128	Zn	Cr, Crm, li	140	12	22	128	
54 85 x xx	WMN 187.160	Zn	Cr, Crm, li	172	12	22	160	
54 86 x xx	WMN 187.224	Zn	Cr, Crm, li	236	12	22	224	

WMN 142



Artik. číslo	Název	Materiál	Povrchová úprava	—	!	—	⊕	⊕
53 77 x xx	WMN 142.096	Zn	Cr, Crm, li	132	16	24	96	
53 78 x xx	WMN 142.128	Zn	Cr, Crm, li	168	18	25	128	

VERONA



Artik. číslo	Název	Materiál	Povrch. úprava	—	!	—	⊕	⊕
00 00 43 x0x	VERONA 160	Zn	Cr, li, Crm	193	24	28	160	

WMN 145



Artik. číslo	Název	Materiál	Povrchová úprava	—	!	—	⊕	⊕
53 83 x xx	WMN 145.160	Zn	Cr, Crm, li	180	15	26	160	

BAGIVA



Artik. číslo	Název	Materiál	Povrchová úprava	—	!	—	⊕	⊕
02 23 8 xx	BAGIVA 128	Zn	Crm, Nim, C	141	14	31	128	

WMN 102



Artik. číslo	Název	Materiál	Povrchová úprava	—	!	—	⊕	⊕
53 06 x xx	WMN 102.128	Zn	Cr, Crm, li	172	18	32	128	

CAROL



Artik. číslo	Název	Materiál	Povrchová úprava	—	!	—	⊕	⊕
000069x0x	CAROL 160	Zn	Cr, cNi, antracit, li	188	16	30	160	
000070x0x	CAROL 320	Zn	Cr, cNi, antracit, li	348	16	30	320	

NOVINKA

WMN 550 SWAROVSKI



Artik. číslo	Název	Materiál	Povrchová úprava	—	!	—	⊕
52 90 0 07	WMN550.128.KR02	Zn, KR	Cr	140	13	25	128
52 90 0 05	WMN550.096.KR02	Zn, KR	Cr	107	13	22	96

WPO 550 SWAROVSKI



Artik. číslo	Název	Materiál	Povrchová úprava	—	!	—	⊕
52 00 0 02	WPO550.032.KR02	Zn, KR	Cr	49	49	24	32
52 90 0 06	WPO550.016.KR02	Zn, KR	Cr	25	25	23	16
52 90 0 09	WPO550.000.KR02	Zn, KR	Cr	13	13	21	-

WMN 633 SWAROVSKI



Artik. číslo	Název	Materiál	Povrchová úprava	—	!	—	⊕
21 00 3 02	WMN 633.128.KR02	Zn, KR	Cr	145	21	25	128
21 00 4 02	WMN 633.096.KR02	Zn, KR	Cr	114	21	25	96

WPO 633 SWAROVSKI



Artik. číslo	Název	Materiál	Povrch. úprava	∅	—	!	⊕
52 92 0 13	WPO 633.A64.KR02	Zn, KR	Cr	86	24	64	
22 00 0 02	WPO 633.B32.KR02	Zn, KR	Cr	50	24	32	

WPO 633 SWAROVSKI WPO 633 SWAROVSKI



Artik. číslo	Název	Materiál	Povrch. úprava	∅	—	!	⊕
52 90 0 12	WMN 633.C32.KR02	Zn, KR	Cr	-	48	21	32
22 00 1 02	WPO 633.017.KR02	Zn, KR	Cr	17	-	21	-

WMN 335K



Artik. číslo	Název	Materiál	Povrch. úprava	—	!	—	⊕
22 04 0 02	WMN 335K.320.KR02	Zn, KR	Cr	328	9	28	320
22 03 9 02	WMN 335K.128.KR02	Zn, KR	Cr	136	9	28	128

WMN 693 SWAROVSKI



Artik. číslo	Název	Materiál	Povrch. úprava	—	!	—	⊕
-	WMN 693.128.KR02	Zn, KR	Cr	144	15	24	128
-	WMN 693.096.KR02	Zn, KR	Cr	110	15	24	96
-	WMN 693.032.KR02	Zn, KR	Cr	47	47	23	32

WPO 693 SWAROVSKI



Artik. číslo	Název	Materiál	Povrch. úprava	—	!	—	⊕
-	WPO 693.031.KR02	Zn, KR	Cr	31	31	21	-
-	WPO 693.015.KR02	Zn, KR	Cr	15	15	21	-

WMN 667 SWAROVSKI



Artik. číslo	Názov	Materiál	Povrch. úprava	▬	!	┌	⊕
52 90 0 14	WMN 667.128.KR02	Zn, KR	Cr	142	14	30	128
52 90 0 15	WMN 667.096.KR02	Zn, KR	Cr	112	14	29	96
52 90 0 16	WMN 667.032.KR02	Zn, KR	Cr	48	14	23	32

WPN 667 SWAROVSKI



Artik. číslo	Názov	Materiál	Povrch. úprava	▬	!	┌	⊕
-	WPN 667 016	Zn, KR	Cr	14	58	23	16

WMN 694 WPO 694



Artik. číslo	Názov	Materiál	Povrch. úprava	▬	!	┌	⊕
22 03 x xx	WMN 694.160	Zn	Cr	180	22	25	160
22 03 x xx	WMN 694.128	Zn	Cr	148	22	24	128
22 03 x xx	WMN 694.096	Zn	Cr	116	22	24	96
22 01.5 03	WPO 694	Zn	Cr	30	30	22	-

WMN 640 SWAROVSKI WPO 640 SWAROVSKI



Artik. číslo	Názov	Materiál	Povrchová úprava	▬	!	┌	⊕
52 90 0 xx	WMN 640.128 KR02	Zn, KR	G,čierna	150	22	25	128
52 90 0 xx	WMN 640.096 KR02	Zn, KR	cCr, čierna	121	22	25	96
52 90 0 xx	WPO 640.032 KR02	Zn, KR	cCr, čierna	65	22	23	32
52 90 0 xx	WPO 640.016 KR02	Zn, KR	cCr, čierna	37	22	21	16

ZARA



Artik. číslo	Názov	Materiál	Povrch. úprava	▬	!	┌	⊕
51 33 x 00	ZARA 128	Zn	Cr	164	25	24	128
51 34 3 00	ZARA 32	Zn	Cr	48	24	20	32

ZARA ZAPUSTENÁ

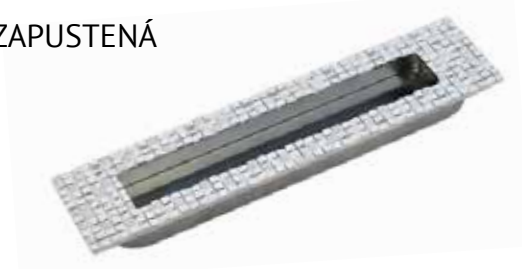

Artik. číslo	Názov	Materiál	Povrch. úprava	▬	!	┌	⊕
51 33 3 01	ZARA ZAPUSTENÁ	Zn	Cr	153	38	13	128

ZARA II. ZARA 32



Artik. číslo	Názov	Materiál	Povrch. úprava	▬	!	┌	⊕
-	ZARA II. 128	Zn	Cr	146	24	18	128
-	ZARA II. 160	Zn	Cr	178	24	18	160
-	ZARA 32	Zn	Cr	48	48	21	32

ZUNA



Artik. číslo	Názov	Materiál	Povrch. úprava	▬	!	┌	⊕
59 71 3 00	ZUNA 160	Zn	Cr	168	28	28	160
59 72 3 00	ZUNA 32	Zn	Cr	28	28	29	32

WMN 040



Artik. číslo	Název	Materiál	Povrch. úprava	☐	!	☐	⊕
46 03 x xx	WMN 040.128	Zn	Cr, pat na Ms, li, Te	140	38	23	128
46 02 x xx	WMN 040.064	Zn	Cr, pat na Ms, li, Te	77	32	20	64
21 00 x xx	WMN 040.032	Zn	Cr, pat na Ms, li, Te	44	35	20	32

TWIX



Artik. číslo	Název	Materiál	Povrch. úprava	☐	!	☐	⊕
22 03 5 02	TWIX 128	Zn	Cr	138	24	26	128
22 03 4 02	TWIX 160	Zn	Cr	170	24	26	160

KUGA



Artik. číslo	Název	Materiál	Povrchová úprava	☐	!	☐	⊕
59 50 x xx	KUGA 128	Zn	G, C	144	11	28	128

ANGELIKA



Artik. číslo	Název	Materiál	Povrchová úprava	☐	!	☐	⊕
25 17 x 00	ANGELIKA 128	Zn	Cr, Ms, Crm, Nim	151	8	34	128
25 18 x 00	ANGELIKA 224	Zn	Cr, Ms, Crm, Nim	247	8	34	224

TAMPA



NOVINKA

Artik. číslo	Název	Materiál	Povrchová úprava	☐	!	☐	⊕
000045x0x	TAMPA 160	Zn	Cr, li, Nim, antracit	185	22	20	160
000044x0x	TAMPA 320	Zn	Cr, li, Nim, antracit	339	23	20	320

BUMERANG



Artik. číslo	Název	Materiál	Povrchová úprava	☐	!	☐	⊕
22 43 x 00	BUMERANG 32	Zn	Cr, Ms, Crm, Nim	50	18	20	32
22 42 x 00	BUMERANG 64	Zn	Cr, Ms, Crm, Nim	81	18	30	64
22 44 x 00	BUMERANG 96	Zn	Cr, Ms, Crm, Nim	119	18	30	96

MINEAPOLIS



Artik. číslo	Název	Materiál	Povrch. úprava	☐	!	☐	⊕
-	MINEAPOLIS	Al	Cr, Crm	351	37	10	

WMN 002



Artik. číslo	Název	Materiál	Povrch. úprava	☐	!	☐	⊕
31 00 3 5x	WMN 002.160	Zn	Cr, Crm, li	190	16	30	160
-	WMN 002.192	Zn	Cr, Crm, li	222	16	30	192
31 00 3 6x	WMN 002.320	Zn	Cr, Crm, li	350	16	30	320

LEA



Artik. číslo	Název	Materiál	Povrchová úprava	☐	!	☐	⊕
51 10 8 37	LEA 96	AL	Crm	118	25	28	96
51 11 8 37	LEA 128	AL	Crm	152	25	28	128
51 12 8 37	LEA 160	AL	Crm	192	25	28	160

LENKA



Artik. číslo	Název	Materiál	Povrchová úprava	☐	!	☐	⊕
51 30 8 37	LENKA 96	AL	Crm	121	25	28	96
51 31 8 37	LENKA 128	AL	Crm	156	25	29	128
51 32 8 37	LENKA 160	AL	Crm	191	25	27	160

NATÁLIA



Artik. číslo	Názov	Materiál	Povrchová úprava	—	!	—	⊕
22 58 x xx	NATÁLIA 128	Zn	Cr, Ms, Crm, Nim	146	18	27	128

SONGO



NOVINKA

Artik. číslo	Názov	Materiál	Povrchová úprava	—	!	—	⊕
55 38 x 00	SONGO 128	Zn	Cr, Crm, Nim	145	20	25	128

NATÁLKA



Artik. číslo	Názov	Materiál	Povrchová úprava	—	!	—	⊕
22 46 x 00	NATÁLKA 96	Zn	Cr, Ms, Crm, Nim	117	13	20	96

STANA



Artik. číslo	Názov	Materiál	Povrchová úprava	—	!	—	⊕
25 40 x 00	STANA 128	Zn	Cr, Ms, Crm, Nim	137	13	26	128
25 41 x 00	STANA 96	Zn	Cr, Ms, Crm, Nim	105	13	25	96

BETA



Artik. číslo	Názov	Materiál	Povrchová úprava	—	!	—	⊕
02 85 x xx	BETA 96	Zn	Cr, Ms, Crm, Nim, C	117	10	26	96
02 86 x xx	BETA 128	Zn	Cr, Ms, Crm, Nim, C	151	10	30	128

CHIARA



Artik. číslo	Názov	Materiál	Povrch. úprava	—	!	—	⊕
59 41 3 00	CHIARA 160	Zn	Cr, Crm, Nim	172	26	38	160
59 42 3 00	CHIARA 320	Zn	Cr, Crm, Nim	332	26	38	320

DUET



Artik. číslo	Názov	Materiál	Povrchová úprava	—	!	—	⊕
22 40 x 00	DUET 128	Zn	Cr, Ms, Crm, Nim	170	18	28	128
22 39 x 00	DUET 96	Zn	Cr, Ms, Crm, Nim	123	12	27	96

SANDRA



Artik. číslo	Názov	Materiál	Povrchová úprava	—	!	—	⊕
25 50 x 00	SANDRA 128	Zn	Cr, Ms, Crm, Nim	138	13	27	128
25 51 x 00	SANDRA 96	Zn	Cr, Ms, Crm, Nim	106	13	27	96

MARÍNA



Artik. číslo	Názov	Materiál	Povrchová úprava	—	!	—	⊕
25 31 x 00	MARÍNA 64	Zn	Cr, Ms, Crm, Nim	81	10	24	64

ADVERB



Artik. číslo	Názov	Materiál	Povrchová úprava	—	!	—	⊕
02 88 x xx	ADVERB 305	S	Cr, Ms, Crm, Nim, C	353	10	34	305
02 88 x xx	ADVERB 320	S	Cr, Ms, Crm, Nim, C	353	10	34	320

GITKA



Artik. číslo	Název	Materiál	Povrchová úprava				
22 59 x xx	GITKA 96	Zn	Cr, Ms, Crm, Nim	114	10	25	96
25 92 x xx	GITKA 128	Zn	Cr, Ms, Crm, Nim	160	11	28	128

GITA



Artik. číslo	Název	Materiál	Povrchová úprava				
02 21 x xx	GITA 96	Zn	Cr, Ms, Crm, Nim, C	117	13	29	96

BRIDGE



Artik. číslo	Název	Materiál	Povrchová úprava				
02 01 8 3x	BRIDGE 128	Zn	Crm, Nim	152	9	29	128

KATRIN



Artik. číslo	Název	Materiál	Povrchová úprava				
25 24 x 00	KATRIN 96	Zn	Cr, Ms, Crm, Nim	120	11	21	96

JAMAHA



Artik. číslo	Název	Materiál	Povrchová úprava				
22 91 x xx	JAMAHA 128	Zn	Cr, Ms, Crm, Nim	165	16	29	128

GOYA



Artik. číslo	Název	Materiál	Povrchová úprava				
22 64 x xx	GOYA 128	Zn	Cr, Ms, Crm, Nim	141	19	23	128
22 65 x xx	GOYA 96	Zn	Cr, Ms, Crm, Nim	106	14	21	96

LEONARDO



Artik. číslo	Název	Materiál	Povrchová úprava				
22 71 x 0x	LEONARDO	Zn	Cr, Ms, Crm, Nim, li	140	18	28	128

SIMONA



Artik. číslo	Název	Materiál	Povrchová úprava				
25 47 x 00	SIMONA 128	Zn	Cr, Ms, Crm, Nim	149	13	27	128
25 48 x 00	SIMONA 96	Zn	Cr, Ms, Crm, Nim	109	13	25	96

JANO



Artik. číslo	Název	Materiál	Povrchová úprava				
22 36 x 00	JANO 128	Zn	Cr, Ms, Crm, Nim	159	17	30	128
22 35 x 00	JANO 96	Zn	Cr, Ms, Crm, Nim	127	17	30	96

JAMO



Artik. číslo	Název	Materiál	Povrchová úprava				
22 94 8 x 0	JAMO 128	Zn	Cr, Ms, Crm, Nim	164	16	29	128
22 93 8 x 0	JAMO 96	Zn	Cr, Ms, Crm, Nim	131	16	28	96

SAMARA



Artik. číslo	Název	Materiál	Povrchová úprava	—	!	—	⊕
55 41 x 00	SAMARA 32	Zn	Cr, Ms, Crm, Nim	43	10	27	32
55 43 x 00	SAMARA 64	Zn	Cr, Ms, Crm, Nim	75	9	24	64

MODUS

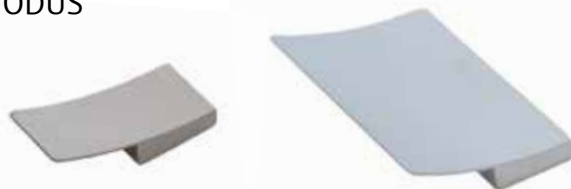

Artik. číslo	Název	Materiál	Povrchová úprava	—	!	—	⊕
55 52 x xx	MODUS	Zn	Crm, Nim	22	18	50	-
55 53 x xx	MODUS 32	Zn	Crm, Nim	50	18	50	32
55 54 x xx	MODUS 64	Zn	Crm, Nim	80	18	50	64

EXPLORER



Artik. číslo	Název	Materiál	Povrchová úprava	—	!	—	⊕
55 55 x xx	EXPLORER 32	Zn	Crm, Nim	50	9	50	32
55 56 x xx	EXPLORER 64	Zn	Crm, Nim	80	8	50	64

FIESTA



Artik. číslo	Název	Materiál	Povrchová úprava	—	!	—	⊕
55 58 x xx	FIESTA 32	Zn	Crm, Nim	40	8	40	32

FOCUS

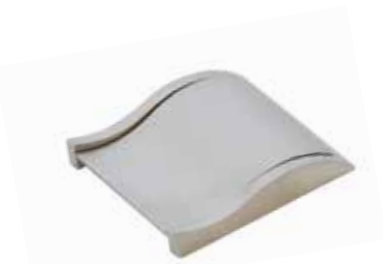

Artik. číslo	Název	Materiál	Povrchová úprava	—	!	—	⊕
55 27 x xx	FOCUS 32	Zn	Crm, Nim	50	50	9	32

WPO 119



Artik. číslo	Název	Materiál	Povrchová úprava	—	!	—	⊕
54 59 x xx	WPO 119.016	Zn	Cr, Crm	38	38	25	16
46 04 9 01	WPO 119.016	Zn	li	38	38	25	16

WPO 019



Artik. číslo	Název	Materiál	Povrchová úprava	—	!	—	⊕
54 64 x xx	WPO 019.A32	Zn	Cr, Crm, li	70	70	25	32

POPULAR



Artik. číslo	Název	Materiál	Povrchová úprava	—	!	—	⊕
55 14 7 00	POPULAR 32	Zn	Crm	55	8	23	32

IVA



Artik. číslo	Název	Materiál	Povrchová úprava	—	!	—	⊕
02 04 x xx	IVA 64	S	Cr, Ms, Crm, Nim, C	72	8	26	64
02 05 x xx	IVA 96	S	Cr, Ms, Crm, Nim, C	104	8	26	96
02 06 x xx	IVA 128	S	Cr, Ms, Crm, Nim, C	136	8	26	128
02 07 x xx	IVA 160	S	Cr, Ms, Crm, Nim, C	168	8	26	160
02 08 x xx	IVA 288	S	Cr, Ms, Crm, Nim, C	296	8	26	288

IDA



Artik. číslo	Název	Materiál	Povrchová úprava	—	!	—	⊕
02 44 x xx	IDA 64	Zn	Cr, Ms, Crm, Nim, C	71	7	35	64
02 45 x xx	IDA 96	Zn	Cr, Ms, Crm, Nim, C	103	7	35	96
02 46 x xx	IDA 128	Zn	Cr, Ms, Crm, Nim, C	135	7	35	128

LEONTÍNA



Artik. číslo	Název	Materiál	Povrch. úprava	☐	!	┌	⊕
22 16 x 00	LEONTÍNA 76	Zn	Cr, Crm, Ms, Nim	93	32	11	76

057



Artik. číslo	Název	Materiál	Povrchová úprava	☐	!	┌	⊕
60 03 8 37	057	P	Cr	125	40	15	-

WMN 124



Artik. číslo	Název	Materiál	Povrchová úprava	☐	!	┌	⊕
53 24 x xx	WMN 124.064	Zn	Cr, Crm, li	74	50	19/13	64
53 25 x xx	WMN 124.096	Zn	Cr, Crm, li, pat. na Ms	106	50	19/13	96
53 26 x xx	WMN 124.128	Zn	Cr, Crm, li, pat. na Ms	138	50	19/13	128

QUATRA



Artik. číslo	Název	Materiál	Povrchová úprava	☐	!	┌	⊕
25 37 x 00	QUATRA	Zn	Cr, Ms, Crm, Nim	86	37	13	-

KAMILA



Artik. číslo	Název	Materiál	Povrchová úprava	☐	!	┌	⊕
51 20 8 37	KAMILA 96	AL	Cr	131	64	18	96
51 22 8 37	KAMILA 160	AL	Cr	211	64	18	160
51 24 8 37	KAMILA 224	AL	Cr	311	64	18	224

MILENA



Artik. číslo	Název	Materiál	Povrchová úprava	☐	!	┌	⊕
22 24 x 00	MILENA 96	Zn	Cr, Ms, Crm, Nim	106	42	12	96

ZUZANA



Artik. číslo	Název	Materiál	Povrch. úprava	☐	!	┌	⊕
22 26 7 00	ZUZANA 192	Zn	Cr	214	40	17	192

FINESA



Artik. číslo	Název	Materiál	Povrchová úprava	☐	!	┌	⊕
55 66 x 00	FINESA 160	Zn	Cr, Nim	173	42	17	160
55 65 x 00	FINESA 96	Zn	Cr, Nim	108	42	17	96
55 64 x 00	FINESA 32	Zn	Cr, Nim	44	35	17	32

HANDLA SO ŠTÍTKOM



Artik. číslo	Název	Materiál	Povrchová úprava	☐	!	┌	⊕
05 47 x xx	HANDLA so štítkom	S	Ni	67	30	25	58

MARKÍZA



Artik. číslo	Název	Materiál	Povrchová úprava	☐	!	┌	⊕
22 45 x 00	MARKÍZA 64	Zn	Cr, Ms, Crm, Nim, pat. na Ms, C	94	27	20	64

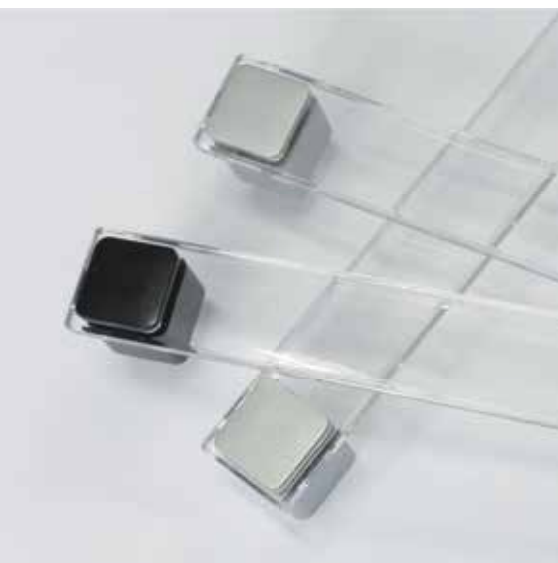
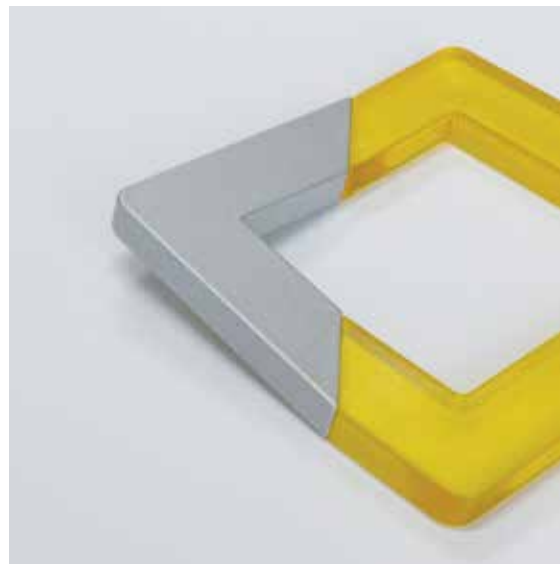
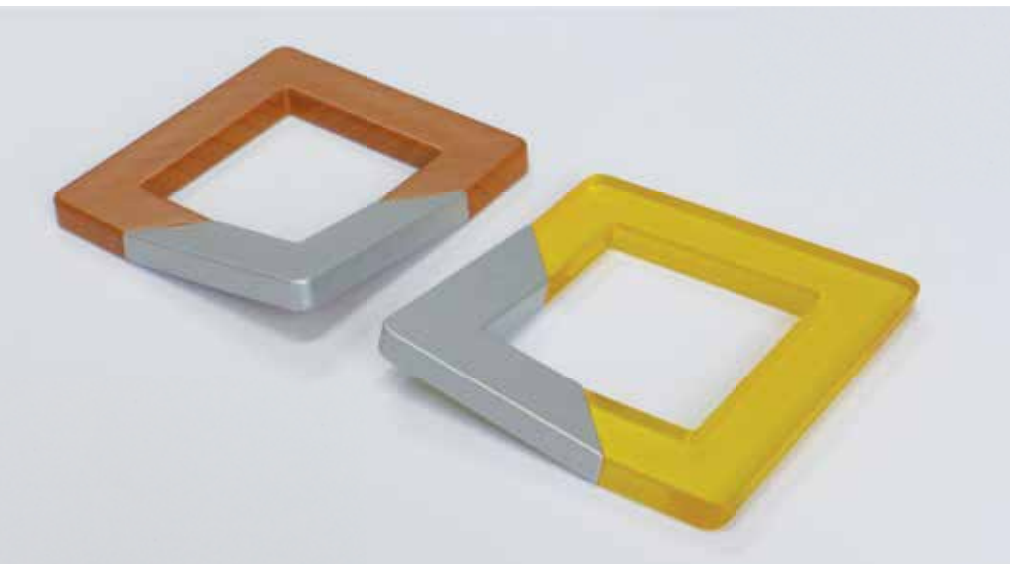

PLASTOVÉ A DREVENÉ ÚCHYTKY
PLASTIC AND WOODEN HANDLES

36



Artik. číslo	Název	Materiál	Povrch. úprava	☰	!	☷	⊕
28 005 01	36 - 128	P, B	C	177	12	34	128

HANA



Artik. číslo	Název	Materiál	Povrch. úprava	☰	!	☷	⊕
28 00 0 01	HANA 64	P	C	114	9	22	64

076



Artik. číslo	Název	Materiál	Povrchová úprava	☰	!	☷	⊕
60 01 8 xx	076 - 64	P, B	Crn, C	86	10	26	64
60 47 8 xx	076A - 96	P, B	Crn, C	122	9	26	96
60 48 8 xx	076B - 128	P, B	Crn, C	150	9	29	128
60 49 8 xx	076C - 160	P, B	Crn, C	200	9	30	160
60 50 8 xx	076E - 288	P, B	Crn, C	317	10	34	288

MARTA



Artik. číslo	Název	Materiál	Povrchová úprava	☰	!	☷	⊕
28 67 8 3x	MARTA 32	P	Crn, Nim	51	18	22	32
28 67 8 3x	MARTA 96	P	Crn, Nim	116	18	28	96
28 67 8 3x	MARTA 128	P	Crn, Nim	148	18	28	128
28 67 8 3x	MARTA 160	P	Crn, Nim	180	18	28	160

66



Artik. číslo	Název	Materiál	Povrch. úprava	☰	!	☷	⊕
28 00 4 01	66 - 96	P, B	C	124	27	26	96

389



Artik. číslo	Název	Materiál	Povrch. úprava	☰	!	☷	⊕
28 00 2 01	389-96	P, B	C	108	17	28	96
60 00 0 73	389-128	P, B	C	141	20	28	128

86



Artik. číslo	Název	Materiál	Povrch. úprava	☰	!	☷	⊕
28 00 3 01	86 - 96	P, B	C	106	18	26	96

329



Artik. číslo	Název	Materiál	Povrch. úprava	☰	!	☷	⊕
-	329 - 128	P, B	C	200	22	26	128

300



Artik. číslo	Název	Materiál	Povrch. úprava	☰	!	☷	⊕
60 23 8 37	300 - 64	P, B	C	110	14	22	64
60 24 8 37	300 - 96	P, B	C	150	14	24	96
-	300 - 128	P, B	C	182	16	26	128
-	300 - 160	P, B	C	214	16	27	160
-	300 - 192	P, B	C	250	16	29	192

366 F



Artik. číslo	Název	Materiál	Povrch. úprava	☰	!	☷	⊕
-	366 F - 192	P, B	C	230	10	28	192

VLASTA



Artik. číslo	Název	Materiál	Povrchová úprava	127	9	30	96
28 63 8 39	VLASTA 96	P	Nim, C				

366



Artik. číslo	Název	Materiál	Povrchová úprava	90	10	21	64
60 06 8 37	366 - 64	P, B	C				
60 07 8 37	366B - 96	P, B	C	129	10	25	96
60 08 8 37	366C - 128	P, B	C	164	12	29	128

094, 096



Artik. číslo	Název	Materiál	Povrchová úprava	150	25	24	128
60 42 x xx	094-128	P, B	G, C				
60 43 x xx	096-160	P, B	G, C	183	25	24	160
60 40 x xx	KNOPOK 414Q	P, B	G, C	40	40	21	-

ELIS



Artik. číslo	Název	Materiál	Povrch. úprava	205	30	30	192
59 73 3 00	ELIS 192	Zn, P	Cr + P				
59 74 3 00	ELIS 256	Zn, P	Cr + P	271	31	32	256

42



Artik. číslo	Název	Materiál	Povrch. úprava	50	14	22	32
28 00 6 01	42 - 32	P, B	G, C				

097



Artik. číslo	Název	Materiál	Povrchová úprava	66	24	29	32
60 60 x xx	097 - 32	P, B	Crn, C				

393



Artik. číslo	Název	Materiál	Povrch. úprava	140	32	14	128
-	393 - 128	P, B	C				

398
014



Artik. číslo	Název	Materiál	Povrch. úprava	153	18	28	96
-	398 - 096	P, B	C				
-	014	P, B	C	50	18	26	-

314

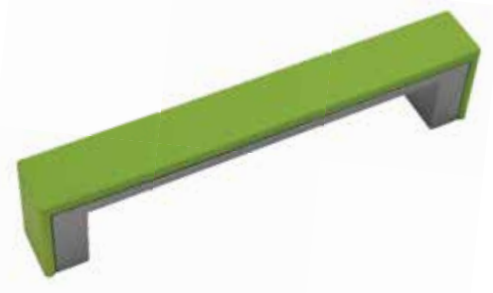

Artik. číslo	Název	Materiál	Povrch. úprava	140	20	32	128
28 00 7 01	314 - 128	P	Cr, C				

337



Artik. číslo	Název	Materiál	Povrchová úprava	173	60	30	128
60 51 x xx	337 - 128	P, B	C				

030



Artik. číslo	Název	Materiál	Povrchová úprava	—	!	—	⊕	⊕
60 44 x xx	030-128	P, B	G, C	140	20	29		128
60 45 x xx	030-160	P, B	G, C	170	20	29		160
60 46 x xx	030-192	P, B	G, C	220	20	29		192

430



Artik. číslo	Název	Materiál	Povrchová úprava	—	!	—	⊕	⊕
60 52 x xx	430-064	P, B	C	110	110	22		64

317



Artik. číslo	Název	Materiál	Povrch. úprava	—	!	—	⊕	⊕
-	317-064	P, B	C	80	80	14		64

318



Artik. číslo	Název	Materiál	Povrch. úprava	—	!	—	⊕	⊕
28 00 0 70	318-064	P, B	C	80	80	14		64

NUMERO



Artik. číslo	Název	Materiál	Povrch. úprava	—	!	—	⊕	⊕
04 02 0 0x	NUMERO 64	P, B	C	87	50	24		64

25

306
603



Artik. číslo	Název	Materiál	Povrchová úprava	—	!	—	⊕	⊕
60 63 x xx	306-160	P, B	C	202	30	30		160
-	603-032	P, B	C	42	46	25		32

062

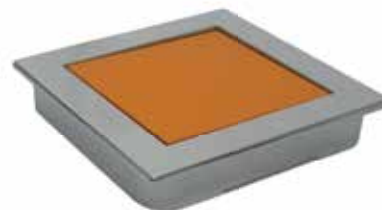

Artik. číslo	Název	Materiál	Povrchová úprava	—	!	—	⊕	⊕
60 54 x xx	062-64	P, B	G, C	78	78	12		64

399



Artik. číslo	Název	Materiál	Povrch. úprava	—	!	—	⊕	⊕
-	399-32	P, B	C	110	110	27		32

310
311

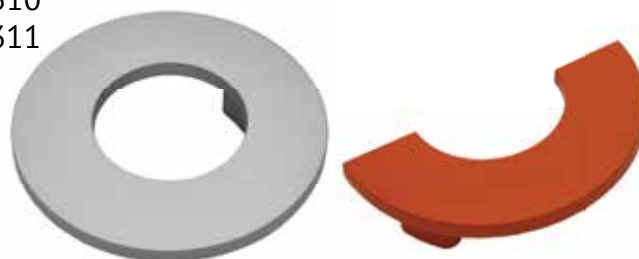

Artik. číslo	Název	Materiál	Povrch. úprava	—	!	—	⊕	⊕
28 00 0 68	310-64	P, B	C	97	97	22		64
28 00 0 6x	311-64	P	C, G	97	48	22		64

312



Artik. číslo	Název	Materiál	Povrch. úprava	—	!	—	⊕	⊕
-	312-32	P	C, G	95	95	25		32

309



Artik. číslo	Názov	Materiál	Povrch. úprava	—	!	—	⊕	⊕
60 26 x xx	309 - 128 prevítaná	P	C, G	168	18	26	128	
60 25 x xx	309 - 128 neprevítaná	P	C, G	168	18	26	128	

VLÁČIK



Artik. číslo	Názov	Materiál	Povrch. úprava	—	!	—	⊕	⊕
25 02 x 00	VLÁČIK 96	R, Zn	C	130	27	23	96	

390



Artik. číslo	Názov	Materiál	Povrch. úprava	—	!	—	⊕	⊕
-	390 - 96	P, B	C	135	40	25	96	

053



Artik. číslo	Názov	Materiál	Povrch. úprava	∅	—	!
-	053	P	C, G	35	14	

056



Artik. číslo	Názov	Materiál	Povrch. úprava	∅	—	!
-	056	P	C, G	50	13	

059



Artik. číslo	Názov	Materiál	Povrch. úprava	∅	—	!	—	⊕	⊕
60 02 8 37	059	P	Crn	50	55	65	14		

GALA



Artik. číslo	Názov	Materiál	Povrchová úprava	∅	—	!
28 10 0 x 0	GALA	P	biela, hnedá, čierna, buk, čerešňa	55	16	

MUŠĽA



Artik. číslo	Názov	Materiál	Povrchová úprava	☰	!	☰	⊕
28 00 0 x0	MUŠĽA	P	biela, hnedá, čierna, buk, čerešňa	88	30	11	

MUŠĽA D



Artik. číslo	Názov	Materiál	Povrchová úprava	☰	!	☰	⊕
23 25 x xx	MUŠĽA D	W	buk, borovica, dub	121	40	16	-

LUCA



Artik. číslo	Názov	Materiál	Povrchová úprava	☰	!	☰	⊕
23 20 8 xx	LUCA 96	W, S	buk, borovica, dub, čerešňa	112	17	30	96

LUCKA



Artik. číslo	Názov	Materiál	Povrchová úprava	☰	!	☰	⊕
23 20 7 xx	LUCKA 64	W, S	buk, borovica, dub, čerešňa	83	17	30	64

BARBORA



Artik. číslo	Názov	Materiál	Povrchová úprava	☰	!	☰	⊕
23 20 3 xx	BARBORA 96	W, S	buk, borovica, dub, čerešňa	112	16	31	96

BARBORKA



Artik. číslo	Názov	Materiál	Povrchová úprava	☰	!	☰	⊕
23 20 4 xx	BARBORKA 64	W, S	buk, bor., dub, lak, jelša	80	16	31	64

INA



Artik. číslo	Názov	Materiál	Povrchová úprava	☰	!	☰	⊕
23 23 8 xx	INA 128	W, S	buk, borovica, dub, čerešňa	172	12	33	128

INKA



Artik. číslo	Názov	Materiál	Povrchová úprava	☰	!	☰	⊕
23 23 9 xx	INKA 96	W, S	buk, borovica, dub, čerešňa	137	12	27	96

ŠIROKÁ



Artik. číslo	Názov	Materiál	Povrchová úprava	☰	!	☰	⊕
23 21 8 xx	ŠIROKÁ 96	W, S	buk, borovica, dub, čerešňa	117	18	29	96

ÚZKA



Artik. číslo	Názov	Materiál	Povrchová úprava	☰	!	☰	⊕
23 20 1 xx	ÚZKA 96	W, S	buk, borovica, dub, čerešňa	120	10	28	96

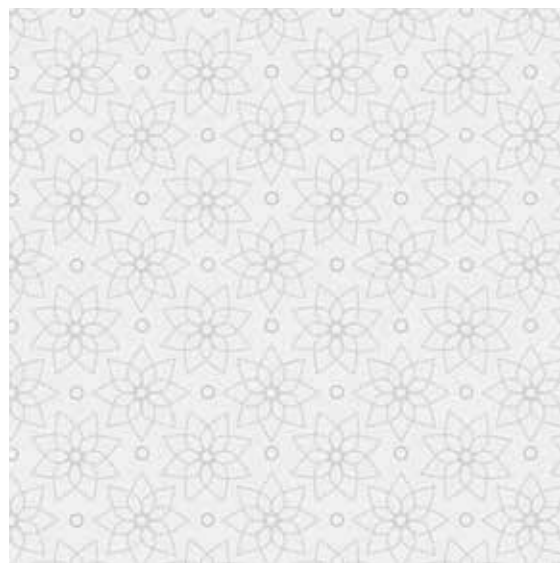

RUSTIKÁLNE ÚCHYTKY
RUSTIC HANDLES

EVITA



NOVINKA

Artik. číslo	Názov	Materiál	Povrchová úprava	—	!	—	⊕
52 54 0 04	EVITA 96	Zn	pat na Ms	111	15	33	96
52 55 0 04	EVITA 128	Zn	pat na Ms	143	15	33	128
52 56 0 04	EVITA 160	Zn	pat na Ms	175	15	33	160

LATINA



NOVINKA

Artik. číslo	Názov	Materiál	Povrchová úprava	—	!	—	⊕
52 57 0 0x	LATINA 64	Zn	pat na Ms, Te	95	14	24	64
52 58 0 0x	LATINA 96	Zn	pat na Ms, Te	131	22	28	96

CALABRIA



NOVINKA

Artik. číslo	Názov	Materiál	Povrchová úprava	—	!	—	⊕
52 59 0 0x	CALABRIA 96	Zn	pat na Ms, Te	130	20	24	96

CATANIA



NOVINKA

Artik. číslo	Názov	Materiál	Povrchová úprava	—	!	—	⊕
52 60 0 0x	CATANIA 64	Zn	pat na Ms, Te	94	16	21	64
52 61 0 0x	CATANIA 96	Zn	pat na Ms, Te	126	16	23	96
52 62 0 0x	CATANIA 128	Zn	pat na Ms, Te	156	16	25	128

LESANA



NOVINKA

Artik. číslo	Názov	Materiál	Povrchová úprava	—	!	—	⊕
NEW	LESANA	Zn	pat na Ms, pat na medi, Te	165	19	25	128

CORNÉLIA



NOVINKA

Artik. číslo	Názov	Materiál	Povrchová úprava	—	!	—	⊕
NEW	CORNÉLIA	Zn	pat na Ms, pat na medi, bronz, Te	128	20	22	96
NEW	CORNÉLIA	Zn	pat na Ms, pat na medi, bronz, Te	160	20	22	128
NEW	CORNÉLIA	Zn	pat na Ms, pat na medi, bronz, Te	192	20	22	160

ANIA



NOVINKA

Artik. číslo	Názov	Materiál	Povrchová úprava	—	!	—	⊕
NEW	ANIA 160	Zn	Te	169	19	26	160

NYA



NOVINKA

Artik. číslo	Názov	Materiál	Povrchová úprava	—	!	—	⊕
NEW	NYA 160	Zn	Te	169	24	25	160

DÁRIA



NOVINKA

Artik. číslo	Názov	Materiál	Povrchová úprava	—	!	—	⊕
NEW	DÁRIA 96	Zn	pat na Ms, pat na medi, Te	106	17	35	96
NEW	DÁRIA 128	Zn	pat na Ms, pat na medi, Te	148	17	35	128
NEW	DÁRIA 160	Zn	pat na Ms, pat na medi, Te	180	17	35	160
NEW	DÁRIA 192	Zn	pat na Ms, pat na medi, Te	212	17	35	192

DÁRIUS



NOVINKA

Artik. číslo	Názov	Materiál	Povrchová úprava	—	!	—	⊕
NEW	DÁRIUS	Zn	pat na Ms, pat na medi, Te	32	32	32	

WPO 647



NOVINKA

Artik. číslo	Názov	Materiál	Povrch. úprava	Ø	h
52 39 0 0x	WPO 647.036	Zn	pat na Ms, Te	36	22

WPO 602



NOVINKA

Artik. číslo	Názov	Materiál	Povrch. úprava	Ø	h
52 38 0 0x	WPO 602.030	Zn	pat na Ms, Te	30	20

WPO 649



NOVINKA

Artik. číslo	Názov	Materiál	Povrch. úprava	Ø	h
52 40 x xx	WPO 649.042	Zn	pat na Ms, Te, Cr, Nim	42	23

LEON HODINY



NOVINKA

Artik. číslo	Názov	Materiál	Povrch. úprava	Ø	h
52 11 0 16	LEON HODINY	Zn+CRM	bronz	35	27

LEON MARKET



NOVINKA

Artik. číslo	Názov	Materiál	Povrch. úprava	Ø	h
52 11 0 14	LEON MARKET	Zn+CRM	Te	35	27

LEON VINTAGE



NOVINKA

Artik. číslo	Názov	Materiál	Povrch. úprava	Ø	h
52 11 0 13	LEON VINTAGE	Zn+CRM	pat na Ms	35	27

PRATO



NOVINKA

Artik. číslo	Názov	Materiál	Povrch. úprava	Ø	h
52 42 0 0x	PRATO	Zn	pat na Ms, Te	24	20

EVIO



NOVINKA

Artik. číslo	Názov	Materiál	Povrchová úprava	Ø	h	h1	h2
52 53 0 xx	EVIO	Zn	bronz, pat na Ms	31	31	22	

WMN 541.064



NOVINKA

Artik. číslo	Názov	Materiál	Povrchová úprava	Ø	h	h1	h2	h3
52 80 0 05	WMN 541.064	Zn	pat na Ms	78	26	8	64	

WMN 5031



NOVINKA

Artik. číslo	Názov	Materiál	Povrchová úprava	Ø	h	h1	h2	h3
52 46 x xx	WMN 5031	Zn	pat na Ms, Te	105	35	21	64	

VIKTÓRIA



Artik. číslo	Názov	Materiál	Povrchová úprava	—	!	—	⊕
52 05 0 11	VIKTÓRIA 96	Zn	pat na Ms	128	18	24	96
52 06 0 11	VIKTÓRIA 128	Zn	pat na Ms	165	18	26	128

VIKTOR



Artik. číslo	Názov	Materiál	Povrchová úprava	—	!	—	⊕
52 15 0 04	VIKTOR	Zn + CRM	pat na Ms	35	35	29	

MARICA



Artik. číslo	Názov	Materiál	Povrchová úprava	—	!	—	⊕
52 08 0 xx	MARICA 64	Zn	pat na Ms, Te	94	12	22	64
52 09 0 xx	MARICA 96	Zn	pat na Ms, Te	126	14	26	96
52 07 0 xx	MARICA 128	Zn	pat na Ms, Te	158	14	26	128

RUDY



Artik. číslo	Názov	Materiál	Povrchová úprava	—	!	—	⊕
25 27 x 00	RUDY 96	Zn	pat na Ms	110	16	21	96

RUSTICA



Artik. číslo	Názov	Materiál	Povrchová úprava	—	!	—	⊕
22 96 x 00	RUSTICA 64	Zn	pat na Ms, čNi	103	14	24	64
25 95 x 00	RUSTICA 96	Zn	pat na Ms, čNi	135	13	24	96

ROMY



Artik. číslo	Názov	Materiál	Povrchová úprava	—	!	—	⊕
21 30 x 0x	ROMY 96	Zn	pat na Ms, Te	110	15	29	96

DENISA



Artik. číslo	Názov	Materiál	Povrchová úprava	—	!	—	⊕
02 26 x 00	DENISA 96	Zn	pat na Ms	120	14	26	96

OXFORD



Artik. číslo	Názov	Materiál	Povrch. úprava	—	!	—	⊕
22 0x x xx	OXFORD 96	Zn	pat na Ms, pat na Ni	136	20	25	96

SAMANTHA SAM



Artik. číslo	Názov	Materiál	Povrchová úprava	—	!	—	⊕
52 00 0 11	SAMANTHA 96	Zn	pat na Ms	114	18	22	96
52 01 0 11	SAMANTHA 128	Zn	pat na Ms	146	18	22	128
52 02 0 11	SAMANTHA 192	Zn	pat na Ms	210	18	22	192
52 04 0 11	SAM KNOPOK	Zn	pat na Ms	24	24	22	-

AGÁTA AGÁT



Artik. číslo	Názov	Materiál	Povrchová úprava	—	!	—	⊕
52 33 0 0x	AGÁTA 96	Zn	pat na Ms, Te	129	21	21	96
52 32 0 0x	AGÁTA 128	Zn	pat na Ms, Te	165	26	27	128
52 34 0 0x	AGÁT KNOPOK	Zn	pat na Ms, Te	44	23	25	-

LEONA KVET



Artik. číslo	Názov	Materiál	Povrchová úprava	—	!	—	⊕
52 19 0 04	LEONA KVET 96	Zn + CRM	pat na Ms	107	18	28	96

LEONA



Artik. číslo	Názov	Materiál	Povrchová úprava	—	!	—	⊕
52 10 0 04	LEONA 96	Zn + CRM	pat na Ms	107	18	28	96

ALEXANDRA



Artik. číslo	Názov	Materiál	Povrchová úprava	—	!	—	⊕
52 13 0 04	ALEXANDRA 96	Zn+CRM	pat na Ms, biela	107	18	26	96
52 13 0 03	ALEXANDRA 96	Zn+CRM	pat na Ms, kvet	107	18	26	96

ANDREA KLAS



Artik. číslo	Názov	Materiál	Povrchová úprava	—	!	—	⊕
52 16 0 04	ANDREA KLAS 96/128	Zn+CRM	pat na Ms	140	18	27	96 - 128

VALENTÍNA VALENTÍN



Artik. číslo	Názov	Materiál	Povrchová úprava	—	!	—	⊕
52 30 0 04	VALENTÍNA 96	Zn+CRM	pat na Ms	126	23	19	96
52 31 0 04	VALENTÍN KNOPOK	Zn+CRM	pat na Ms	31	31	19	-

LEON LEON KLAS



Artik. číslo	Názov	Materiál	Povrch. úprava	∅	—
52 11 0 04	LEON	Zn + CRM	pat na Ms	34	25
52 11 0 05	LEON KLAS	Zn + CRM	pat na Ms	34	25

ALEXANDRO KVET



Artik. číslo	Názov	Materiál	Povrch. úprava	∅	—
52 12 0 04	ALEXANDRO KVET	Zn+CRM	pat na Ms	34	25

ANDREJ KLAS



Artik. číslo	Názov	Materiál	Povrch. úprava	∅	—
52 18 0 04	ANDREJ KLAS	Zn+CRM	pat na Ms	29	24

OPAVIA KLAS



Artik. číslo	Názov	Materiál	Povrch. úprava	∅	—
52 21 0 04	OPAVIA KLAS	Zn+CRM	pat na Ms	31	25

P 18



Artik. číslo	Názov	Materiál	Povrch. úprava	—	!	—
52 00 1 14	P 18	Zn+CRM	pat na Ms	58	34	25

M 16 P 16



Artik. číslo	Názov	Materiál	Povrch. úprava	—	!	—	⊕
22 00 x 4	M 16 - 96	Zn+CRM	pat na Ms	136	30	32	96
04 00 0 17	P 16	Zn+CRM	pat na Ms	67	27	30	-

BISCUIT KLAS



Artik. číslo	Názov	Materiál	Povrchová úprava	—	!	—	⊕
52 20 0 04	BISCUIT KLAS 96	Zn+CRM	pat na Ms	116	24	34	96

BISCUIT



Artik. číslo	Názov	Materiál	Povrchová úprava	—	!	—	⊕
52 23 0 04	BISCUIT 96	Zn+CRM	pat na Ms	116	24	34	96

PEGGY KLAS



Artik. číslo	Názov	Materiál	Povrchová úprava	—	!	—	⊕
52 27 0 04	PEGGY KLAS 96	Zn+CRM	pat na Ms	106	54	24	96

PEGGY



Artik. číslo	Názov	Materiál	Povrchová úprava	—	!	—	⊕
52 25 0 04	PEGGY 96	Zn+CRM	pat na Ms	106	54	24	96

MEGGY KLAS



Artik. číslo	Názov	Materiál	Povrchová úprava	—	!	—	⊕
52 28 0 04	MEGGY KLAS 96	Zn+CRM	pat na Ms	122	20	29	96

AGGY KVET



Artik. číslo	Názov	Materiál	Povrchová úprava	—	!	—	⊕
52 29 0 04	AGGY KVET 96	Zn+CRM	pat na Ms	118	24	30	96

M 56



Artik. číslo	Názov	Materiál	Povrch. úprava	—	!	—	⊕
21 00 0 17	M 56 - 128	Zn+CRM	Te + biela	150	20	30	128
21 00 1 17	M 56 - 128	Zn+CRM	Te + čierna	150	20	30	128

M 53



Artik. číslo	Názov	Materiál	Povrch. úprava	—	!	—	⊕
21 00 8 17	M 53 - 128	Zn+CRM	Te + biela	146	25	26	28
21 00 0 18	M 53 - 128	Zn+CRM	bronz + biela	146	25	26	128
21 00 0 11	M 53 - 128	Zn+CRM	meď + biela	146	25	26	128

LISA ELISA



Artik. číslo	Názov	Materiál	Povrchová úprava	—	!	—	⊕
21 20 x 00	LISA 96	Zn	pat. na Ms, Te	108	13	25	96
21 21 x xx	ELISA 96	Zn, S	pat. na Ms, Te	153	24	25	96

GIULLIA GIULLIO



Artik. číslo	Názov	Materiál	Povrchová úprava	—	!	—	⊕
59 37 x xx	GIULLIA 128	Zn	pat. na Ms, Te	155	38	23	128
-	GIULLIO	Zn	pat. na Ms, Te	38	38	22	-

WMN 603



Artik. číslo	Názov	Materiál	Povrchová úprava	—	!	—	⊕	⊕
52 80 0 04	WMN 603.096	Zn	pat. na Ms, Te	112	24	23	96	
52 81 0 04	WMN 603.128	Zn	pat. na Ms, Te	134	24	23	128	
52 36 0 0x	WPO 603.032	Zn	pat. na Ms, Te	42	9	22	32	

WMN 555



Artik. číslo	Názov	Materiál	Povrch. úprava	—	!	—	⊕	⊕
21 00 x 1x	WMN 555.160	Zn	pat. na Ms, Te	171	11	30	160	

WMN 532



Artik. číslo	Názov	Materiál	Povrch. úprava	—	!	—	⊕	⊕
21 00 7 14	WMN 532.128	Zn	pat. na Ms	154	32	24	128	
21 00 8 14	WMN 532.096	Zn	pat. na Ms	120	32	23	96	

WMN 611



Artik. číslo	Názov	Materiál	Povrch. úprava	—	!	—	⊕	⊕
21 00 9 1x	WMN 611.128	Zn	pat. na Ms, Te	153	28	28	128	
21 01 0 1x	WMN 611.096	Zn	pat. na Ms, Te	121	25	28	96	
21 01 1 1x	WMN 611.032	Zn	pat. na Ms, Te	47	20	20	32	

MAREA



Artik. číslo	Názov	Materiál	Povrchová úprava	—	!	—	⊕	⊕
55 13 x xx	MAREA 96	Zn	Cr, Ms, Crm, Nim, pat	141	12	21	96	

WMN 675



Artik. číslo	Názov	Materiál	Povrch. úprava	—	!	—	⊕	⊕
-	WMN 675.192	Zn	pat. na Ms, Te	250	23	28	192	
-	WMN 675.128	Zn	pat. na Ms, Te	166	23	28	128	
-	WMN 675.096	Zn	Pat. na Ms, Te	140	21	26	96	

WMN 612



Artik. číslo	Názov	Materiál	Povrch. úprava	—	!	—	⊕	⊕
21 00 7 17	WMN 612.128	Zn	pat. na Ms, Te	138	20	25	128	
21 00 3 14	WMN 612.128	Zn	pat. na Ms, Te	138	20	25	128	
52 35 0 04	WPO 612.032	Zn	pat. na Ms, Te	42	20	23	32	

FORTUNA



NOVINKA

Artik. číslo	Názov	Materiál	Povrchová úprava	∅	—	!	—	⊕	⊕
52 51 0 10	FORTUNA 128	Zn	bronz	148	24	23	24	128	
52 52 0 10	FORTUNA 160	Zn	bronz	180	24	23	24	160	

WMN 628

WPO 628



Artik. číslo	Názov	Materiál	Povrch. úprava	—	!	—	⊕	⊕
52 00 0 xx	WMN 628.224	Zn	pat. na Ms, Te	255	27	28	224	
52 00 0 xx	WMN 628.128	Zn	pat. na Ms, Te	160	27	28	128	
52 00 0 xx	WMN 628.096	Zn	pat. na Ms, Te	128	25	25	96	
52 00 0 xx	WPO 628.000	Zn	pat. na Ms, Te	34	34	24	-	

WMN 538



Artik. číslo	Názov	Materiál	Povrch. úprava	—	!	—	⊕	⊕
21 0x x 1x	WMN 538.128	Zn	pat. na Ms, Te	192	28	23	128	
21 0x x 1x	WMN 538.096	Zn	pat. na Ms, Te	160	28	23	96	

WMN 683



Artik. číslo	Názov	Materiál	Povrch. úprava	☐	!	⊕	⊕
52 71 x xx	WMN 683.128	Zn	pat na Ms, Te	166	24	30	128
52 70 x xx	WMN 683.096	Zn	pat na Ms, Te	135	21	30	96

WMN 604



Artik. číslo	Názov	Materiál	Povrch. úprava	☐	!	⊕	⊕
21 00 x xx	WMN 604.128	Zn	pat na Ms, Te	172	26	25	128
21 00 x xx	WMN 604.096	Zn	pat na Ms, Te	136	26	25	96

WMN 668



Artik. číslo	Názov	Materiál	Povrch. úprava	☐	!	⊕	⊕
52 68 x xx	WMN 668.128	Zn	pat na Ms, Te	172	17	27	128
52 67 x xx	WMN 668.096	Zn	pat na Ms, Te	140	17	27	96

WMN 695



Artik. číslo	Názov	Materiál	Povrch. úprava	☐	!	⊕	⊕
52 65 x xx	WMN 695.128	Zn	pat na Ms, Te	142	25	26	128
52 64 x xx	WMN 695.096	Zn	pat na Ms, Te	109	22	25	96

GLADIOLA



Artik. číslo	Názov	Materiál	Povrchová úprava	☐	!	⊕	⊕
22 23 x 00	GLADIOLA 128	Zn	Cr, Ms, Crm, Nim, pat	160	14	24	128
22 22 x 00	GLADIOLA 96	Zn	Cr, Ms, Crm, Nim, pat	127	13	24	96

WPO 683



Artik. číslo	Názov	Materiál	Povrch. úprava	☐	!	⊕	⊕
52 69 x xx	WPO 683.028	Zn	pat na Ms, Te	28	28	28	

WPO 604



Artik. číslo	Názov	Materiál	Povrch. úprava	☐	!	⊕	⊕
52 37 0 0x	WPO 604.032	Zn	pat na Ms, Te	50	26	24	32

WPO 668



Artik. číslo	Názov	Materiál	Povrch. úprava	☐	!	⊕	⊕
52 66 x xx	WPO 668	Zn	pat na Ms, Te	30	30	23	

WPO 695



Artik. číslo	Názov	Materiál	Povrch. úprava	☐	!	⊕	⊕
52 78 0 0x	WPO 695	Zn	pat na Ms, Te	31	31	22	

KALA



Artik. číslo	Názov	Materiál	Povrchová úprava	☐	!	⊕	⊕
22 21 x 00	KALA	Zn	Cr, Ms, Crm, Nim, pat	27	27	25	

HERKULES



Artik. číslo	Názov	Materiál	Povrchová úprava	∅	—	!	—	!
21 12 4 03	HERKULES KNOPOK	Zn	G	35	20	21		
21 64 6 05	PODLOŽKA KU KNOPKU	Zn	G	63	35	3		

CERBERUS



Artik. číslo	Názov	Materiál	Povrchová úprava	∅	—	!	—	!
21 13 4 03	CERBERUS	Zn	G	25	-	-	23	
21 64 6 05	PODLOŽKA KU KNOPKU	Zn	G	-	63	35	3	

ZVONČEK ZVONČEK KNOPOK



Artik. číslo	Názov	Materiál	Povrchová úprava	∅	—	!	—	!
22 97 x xx	ZVONČEK	Zn	G	28	80	22	24	
22 97 x 03	ZVONČEK KNOPOK	Zn	G	28	-	-	22	

TANGO



Artik. číslo	Názov	Materiál	Povrchová úprava	∅	—	!	—	!
21 03 x 00	TANGO	Zn	G	37	-	-	23	

HELENA



Artik. číslo	Názov	Materiál	Povrchová úprava	—	!	—	!	⊕	⊖
21 37 x 00	HELENA 82	Zn	G	100	48	20	82		

SÝRIUS



Artik. číslo	Názov	Materiál	Povrchová úprava	—	!	—	!	⊕	⊖
21 45 x 00	SÝRIUS	Zn	G	55	34	16	-		

GORGONA



Artik. číslo	Názov	Materiál	Povrchová úprava	—	!	—	!	⊕	⊖
21 31 x 00	GORGONA 80	Zn	G	100	38	15	80		

ACHILES



Artik. číslo	Názov	Materiál	Povrchová úprava	—	!	—	!	⊕	⊖
21 40 x 00	ACHILES	Zn	G	31	53	20	-		

PANDORA



Artik. číslo	Názov	Materiál	Povrchová úprava	—	!	—	!	⊕	⊖
21 33 x 00	PANDORA 78	Zn	G	90	45	15	78		

HOMÉR



Artik. číslo	Názov	Materiál	Povrchová úprava	—	!	—	!	⊕	⊖
21 43 x 00	HOMÉR	Zn	G	39	46	16	-		

ANTIK SKLOPNÁ



Artik. číslo	Názov	Materiál	Povrch. úpr.	96	43	15	74
01 43 x 00	ANTIK SKLOPNÁ 74	Zn	G				

ANTIK



Artik. číslo	Názov	Materiál	Povrchová úprava	∅	24	-	20
01 40 x 00	ANTIK 24	Zn	G	24	-	-	20
01 40 x 00	ANTIK 32	Zn	G	32	-	-	24

HALFAR



Artik. číslo	Názov	Materiál	Povrchová úprava	106	48	18	71
21 00 x 54	HALFAR 71	Zn	Ms, pat				

AMOS



Artik. číslo	Názov	Materiál	Povrchová úprava	102	50	15	76
21 00 x 55	AMOS 76	Zn	Ms, pat				

RAMSES II.



Artik. číslo	Názov	Materiál	Povrchová úprava	100	35	15	-
21 00 x 02	RAMSES II.	Zn	Ms, pat				

RAMSES



Artik. číslo	Názov	Materiál	Povrchová úprava	100	35	15	-
21 00 x 01	RAMSES	Zn	Ms, pat				

RUKOK



Artik. číslo	Názov	Materiál	Povrchová úprava	82	28	20	-
21 00 x 06	RUKOK	Zn	Ms, pat				

RUBENS



Artik. číslo	Názov	Materiál	Povrchová úprava	62	16	20	-
21 00 x 07	RUBENS	Zn	Ms, pat				

OKTÁVA



Artik. číslo	Názov	Materiál	Povrchová úprava	89	28	20	-
21 00 x 05	OKTÁVA	Zn	Ms, pat				

ORINGEL



Artik. číslo	Názov	Materiál	Povrchová úprava	67	29	20	-
21 00 x 14	ORINGEL	Zn	Ms, pat				

URÁN



Artik. číslo	Názov	Materiál	Povrchová úprava	∅	!	∏	⊕
21 00 x 18	URÁN	Zn	Ms, pat	65	33	20	-

ROKOKO



Artik. číslo	Názov	Materiál	Povrchová úprava	∅	!	∏	⊕
21 00 x 19	ROKOKO	Zn	Ms, pat	53	39	19	-

ORIENT



Artik. číslo	Názov	Materiál	Povrchová úprava	∅	!	∏	⊕
21 00 x 20	ORIENT	Zn	Ms, pat	68	37	18	-

OPERA



Artik. číslo	Názov	Materiál	Povrchová úprava	∅	!	∏	⊕
21 00 x 16	OPERA	Zn	Ms, pat	50	33	14	-

QUATRO



Artik. číslo	Názov	Materiál	Povrch. úprava	∅	!	∏	⊕
21 00 x 29	QUATRO	Zn	Ms, pat	113	45	20	-

LEO



Artik. číslo	Názov	Materiál	Povrchová úprava	∅	!	∏	⊕
21 00 x 31	LEO	Zn	Ms, pat	58	35	12	-

ROTO



Artik. číslo	Názov	Materiál	Povrchová úprava	∅	!	∏	⊕
21 00 x 29	ROTO	Zn	Ms, pat	32	95	32	24

LOGO



Artik. číslo	Názov	Materiál	Povrchová úprava	∅	!	∏	⊕
21 00 x 47	LOGO	Zn	Ms, pat	41	-	-	22

MORÉNA



Artik. číslo	Názov	Materiál	Povrchová úprava	∅	!	∏	⊕
21 00 x 56	MORÉNA 87	Zn	Ms, pat	112	18	22	87

MERINO BIG MERINO



Artik. číslo	Názov	Materiál	Povrchová úprava	∅	!	∏	⊕
21 00 x 50	MERINO	Zn	Ms, pat	32	-	-	25
21 00 x 34	BIG MERINO	Zn	Ms, pat	49	-	-	32

HINDU



Artik. číslo	Názov	Materiál	Povrchová úprava	—	!	—	⊕
21 00 x 64	HINDU 96	Zn	Ms, pat	153	29	28	96

MONY



Artik. číslo	Názov	Materiál	Povrchová úprava	—	!	—	⊕
21 00 x 53	MONY 71	Zn	Ms, pat	-	33	20	71

ORION II.



Artik. číslo	Názov	Materiál	Povrchová úprava	—	!	—	⊕
21 00 x 15	ORION II.	Zn	Ms, pat	168	27	18	-

TOLIAR



Artik. číslo	Názov	Materiál	Povrchová úprava	—	!	—	⊕
21 00 x 26	TOLIAR	Zn	Ms, pat	45	38	3	

PLUTO



Artik. číslo	Názov	Materiál	Povrchová úprava	—	!	—	⊕
21 00 x 23	PLUTO	Zn	Ms, pat	46	32	4	

ROKO



Artik. číslo	Názov	Materiál	Povrchová úprava	—	!	—	⊕
21 00 x 25	ROKO	Zn	Ms, pat	43	29	3	

LOGO P



Artik. číslo	Názov	Materiál	Povrchová úprava	∅	—	!	—
21 00 x 48	LOGO P	Zn	Ms, pat	38	-	-	20

OKTAN



Artik. číslo	Názov	Materiál	Povrchová úprava	∅	—	!	—
21 00 x 51	OKTAN	Zn	Ms, pat	-	32	32	22

IKAROS



Artik. číslo	Názov	Materiál	Povrchová úprava	—	!	—	⊕
21 15 x 00	IKAROS	Zn	Ms, pat	63	35	3	

DANTHE



Artik. číslo	Názov	Materiál	Povrchová úprava	—	!	—	⊕
21 60 x 00	DANTHE	Zn	Ms, pat	46	22	3	

PARIS



Artik. číslo	Názov	Materiál	Povrchová úprava	—	!	—	⊕
21 00 x 21	PARIS	Zn	Ms, pat	50	28	4	

PERSEUS ZLATAR PLATÓN



Artik. číslo	Názov	Materiál	Povrchová úprava	—	!	—	⊕
21 55 x 00	PERSEUS	Zn	Ms, pat	70/54	28	6	
21 00 x 40	ZLATAR	Zn	Ms, pat	80	34	7	
21 51 x 00	PLATÓN	Zn	Ms, pat	65	27	6	

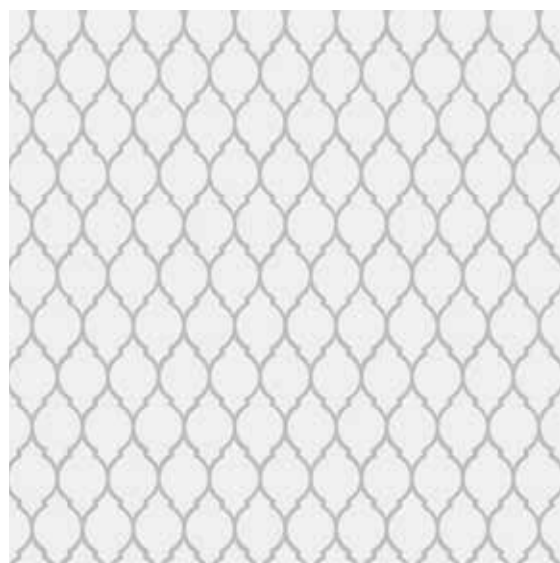

KNOPKY

KNOBS

SQUARE



Artik. číslo	Název	Materiál	Povrchová úprava			
25 32 x 00	SQUARE	Zn	Cr, Crm, Nim	45	45	22

KAMIL



Artik. číslo	Název	Materiál	Povrchová úprava			
25 45 x 00	KAMIL	Zn	Cr, Ms, Crm, Nim	28	18	23

STANO



Artik. číslo	Název	Materiál	Povrchová úprava			
25 42 x 00	STANO	Zn	Cr, Ms, Crm, Nim	32	20	23

STEFAN



Artik. číslo	Název	Materiál	Povrchová úprava			
25 57 x 00	STEFAN	Zn	Cr, Ms, Crm, Nim	29	24	23

JÁVA



Artik. číslo	Název	Materiál	Povrch. úprava				
22 92 x xx	JÁVA 16	Zn	Cr, Ms, Crm, Nim	43	21	25	16

SOKOL



Artik. číslo	Název	Materiál	Povrchová úprava	∅			
25 91 x xx	SOKOL	Zn	Cr, Ms, Crm, Nim, li	12	-	-	22

KAMO



Artik. číslo	Název	Materiál	Povrchová úprava			
25 46 x 00	KAMO	Zn	Cr, Ms, Crm, Nim	27	24	23

SANDRO



Artik. číslo	Název	Materiál	Povrchová úprava	∅			
25 52 x 00	SANDRO	Zn	Cr, Ms, Crm, Nim	28	-	-	23

SIMON



Artik. číslo	Název	Materiál	Povrchová úprava			
25 49 x 00	SIMON	Zn	Cr, Ms, Crm, Nim	32	20	23

JARO



Artik. číslo	Název	Materiál	Povrchová úprava	∅			
25 98 x 00	JARO 28	Zn	Cr, Ms, Crm, Nim	28	-	-	24

STILO



Artik. číslo	Název	Materiál	Povrchová úprava	∅			
55 20 x xx	STILO	Zn	Cr, Ms, Crm, Nim	15	-	-	21

PICASO



Artik. číslo	Název	Materiál	Povrchová úprava	∅			
22 86 x xx	PICASO	Zn	Cr, Ms, Crm, Nim	17	-	-	28
22 88 x xx	PICASO K	Zn	Cr, Ms, Crm, Nim	17/15	-	-	31
22 87 x xx	PICASO P	Zn	Cr, Ms, Crm, Nim	17/20	-	-	30

TIBER



Artik. číslo	Název	Materiál	Povrchová úprava	∅			
04 26 x xx	TIBER	Zn	Cr, Ms, Crm, Nim, C	20	-	-	32

KUGEL



Artik. číslo	Název	Materiál	Povrchová úprava	∅			
04 20 x xx	KUGEL	Zn	Cr, Ms, Crm, Nim, C	25	-	-	33

D 11 D 12



Artik. číslo	Název	Materiál	Povrchová úprava	∅			
-	D 11	Zn	Cr, Crm, Nim, li	11	-	-	21
-	D 12	Zn	Cr, Crm, Nim, li	20	-	-	23

VLASTO



Artik. číslo	Název	Materiál	Povrchová úprava	∅			
28 04 8 39	VLASTO	P	Nim	20	-	-	26

TAPER



Artik. číslo	Název	Materiál	Povrchová úprava	∅			
25 93 x 00	TAPER	Zn	Cr, Ms, Crm, Nim	25	-	-	25

25



Artik. číslo	Název	Materiál	Povrch. úprava			
04 00 0 01	25	P, B	C	16	16	19

OTHELO



Artik. číslo	Název	Materiál	Povrchová úprava			
22 79 x 0x	OTHELO	Zn	Cr, Ms, Crm, Nim	37	26	27

DITMAR



Artik. číslo	Název	Materiál	Povrchová úprava			
25 34 x 00	DITMAR	Zn	Cr, Ms, Crm, Nim	36	23	27

WPO 111



Artik. číslo	Název	Materiál	Povrchová úprava			
54 58 x xx	WPO 111.000	Zn	Cr, Crm, li, Nim, pat na Ms, Te	30	15	16

TIROL



Artik. číslo	Název	Materiál	Povrch. úprava				
00 00 48 x00	TIROL	Zn	G	25	13	15	-

TON



Artik. číslo	Název	Materiál	Povrch. úprava	∅			
-	TON	Zn	Cr, Crm, li, Nim	20	-	-	20

BALADA BALADA K2 BALADA D



Artik. číslo	Název	Materiál	Povrchová úprava	∅			
05 84 x 00	BALADA	Zn	Cr, Ms, Crm, Nim, C	12	-	-	28
05 85 x xx	BALADA K2	Zn	Cr, Ms, Crm, Nim, C	12	-	-	28
03 46 x xx	BALADA D	Zn, W	Crm, Nim + buk lak, jetša	10	-	-	31

LABEX



Artik. číslo	Název	Materiál	Povrch. úprava	∅	!	
04 00 0 03	LABEX	Zn	Nim	30		20

22



Artik. číslo	Název	Materiál	Povrchová úprava	∅	!	
04 22 x xx	22	Zn	Cr, Ms, Crm, Nim, C	22	-	21
04 22 x 01	22 bez podložky	Zn	Cr, Ms, Crm, Nim, C	22	-	19

YARIS



Artik. číslo	Název	Materiál	Povrchová úprava	!	
22 57 x xx	YARIS	Zn	Cr, Ms, Crm, Nim	40	19 30

WPO 694



Artik. číslo	Název	Materiál	Povrch. úprava	!	
21 00 5 03	WPO 694	Zn, KR	Cr	30	30 22

WIND



Artik. číslo	Název	Materiál	Povrchová úprava	!	
22 61 x xx	WIND	Zn	Cr, Ms, Crm, Nim	52	17 26

WPO 693



Artik. číslo	Název	Materiál	Povrch. úprava	!	
-	WPO 693	Zn, KR	Cr	15	15 21

398



Artik. číslo	Název	Materiál	Povrch. úprava	!		⊕	⊖
-	398	P, B	C	18	45 26		

419



Artik. číslo	Název	Materiál	Povrch. úprava	∅	!
60 21 8 37	419	P, B	C	52	38

439



Artik. číslo	Název	Materiál	Povrch. úprava	∅	!
-	439	P, B	C	70	25

008



Artik. číslo	Název	Materiál	Povrch. úprava	∅	!
60 22 8 37	008	P, B	C	52	22

434Q 434



Artik. číslo	Název	Materiál	Povrchová úprava	∅	!	
-	434Q	P	G, C	-	40 14	40
-	434	P	G, C	40	-	40

425



Artik. číslo	Název	Materiál	Povrch. úprava	∅	!	
-	425	P, B	C	70	-	29

414Q
414

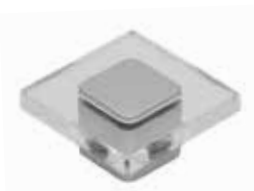

Artik. číslo	Názov	Materiál	Povrchová úprava	∅	—	!	—
60 40 1 00	414Q	P,B	G, C	-	40	40	21
60 41 1 00	414	P,B	G, C	40	-	-	21

440



Artik. číslo	Názov	Materiál	Povrchová úprava	∅	—	!	—
60 39 x xx	440	P,B	G, C	65	-	-	21

24Q
024

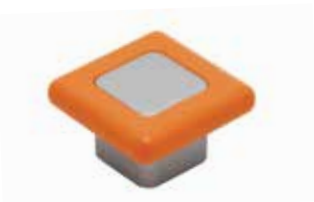

Artik. číslo	Názov	Materiál	Povrchová úprava	∅	—	!	—
60 30 1 xx	24Q	P,B	G, C	-	36	36	21
-	024	P,B	G, C	36	-	-	21

AQUA



Artik. číslo	Názov	Materiál	Povrchová úprava	∅	—	!	—
22 81 x xx	AQUA	P,B	biela, Ms, Cr	36	-	-	27

ŠTVORLÍSTOK



Artik. číslo	Názov	Materiál	Povrchová úprava	∅	—	!	—
04 00 1 xx	ŠTVORLÍSTOK	P,B	C	31	-	-	22

415



Artik. číslo	Názov	Materiál	Povrchová úprava	∅	—	!	—
60 53 x xx	415	P,B	C	55	55	-	25

MEDVEDÍKY
SAMOLEPIACE



Artik. číslo	Názov	Materiál	Povrch. úprava	∅	—	!	—
-	MEDVEDÍK	P	C	-	82/103	72/91	8

STRAŠIDIELKO



Artik. číslo	Názov	Materiál	Povrchová úprava	∅	—	!	—
04 00 x xx	STRAŠIDIELKO	P,B	C	100	95	-	22

SLON



Artik. číslo	Názov	Materiál	Povrchová úprava	∅	—	!	—
60 20 0 0x	SLON 427E	P,B	C	52	55	-	25

RYBA



Artik. číslo	Názov	Materiál	Povrchová úprava	∅	—	!	—
60 20 0 2x	RYBA 427P	P,B	C	41	46	-	23

MAČKA



Artik. číslo	Názov	Materiál	Povrchová úprava		!	
60 20 0 3x	MAČKA 427G	P, B	C	55	27	24

MOTÝĽ



Artik. číslo	Názov	Materiál	Povrchová úprava		!	
60 20 0 1x	MOTÝĽ 427F	P, B	C	70	53	27

KROKODÍL ŽABA



Artik. číslo	Názov	Materiál	Povrchová úprava		!	
25 01 9 00	KROKODÍL	R, B	C	55	40	25
25 00 1 00	ŽABA	R, B	C	47	42	24

ZAJKO LIENKA



Artik. číslo	Názov	Materiál	Povrchová úprava		!	
25 01 8 00	ZAJKO	R, B	C	36	40	23
25 00 0 01	LIENKA	R, B	C	44	42	23

VLÁČIK KNOPOK



NOVINKA

Artik. číslo	Názov	Materiál	Povrchová úprava		!	
25 02 x x1	VLÁČIK KNOPOK	R, S	C	52	27	25

AUTÍČKO ŽLTÉ BLESK MC



NOVINKA

Artik. číslo	Názov	Materiál	Povrchová úprava		!	
	AUTÍČKO ŽLTÉ	R, S	C	50	39	23
25 00 0 10	BLESK MC	R, S	C	50	45	23

VLÁČIK TOMÁŠ LIETADLO



NOVINKA

Artik. číslo	Názov	Materiál	Povrchová úprava		!	
25 00 0 08	VLÁČIK TOMÁŠ	R, S	C	46	32	23
25 00 0 07	LIETADLO	R, S	C	46	36	24

BASKET LOPTA



NOVINKA

Artik. číslo	Názov	Materiál	Povrchová úprava	∅	!
25 00 0 16	BASKET	R, S	C	40	25
04 00 3 00	LOPTA	R, S	C	40	24

RUGBY SMAJÍK



NOVINKA

Artik. číslo	Názov	Materiál	Povrchová úprava		!	
25 00 0 15	RUGBY	R, S	C	48	31	24
25 00 0 09	SMAJÍK	R, S	C	42	42	25

KVIETOK AUTO

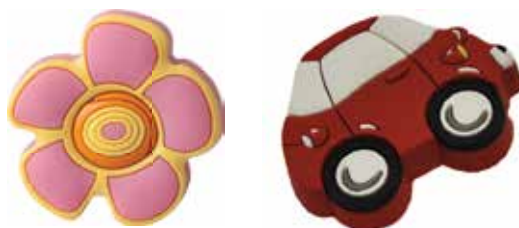

Artik. číslo	Názov	Materiál	Povrchová úprava	∅	!
04 00 4 0x	KVIETOK	R, S	C	40	24
25 00 0 00	AUTO	R, S	C	36	24

SLNIEČKO MESIAČIK



NOVINKA

Artik. číslo	Názov	Materiál	Povrchová úprava	☐	!	☐
25 00 0 05	SLNIEČKO	R, S	C	46	46	23
25 00 0 06	MESIAČIK	R, S	C	57	46	23

SOVIČKA MOTÝL ZELENÝ



NOVINKA

Artik. číslo	Názov	Materiál	Povrchová úprava	☐	!	☐
25 00 0 02	SOVIČKA	R, S	C	39	39	23
25 00 0 17	MOTÝL ZELENÝ	R, S	C	46	45	24

KURIATKO KOHÚTIK



Artik. číslo	Názov	Materiál	Povrchová úprava	☐	!	☐
25 02 2 00	KURIATKO	R, B	C	36	35	24
25 02 1 00	KOHÚTIK	R, B	C	36	40	24

PONY KRAVIČKA



Artik. číslo	Názov	Materiál	Povrchová úprava	☐	!	☐
25 01 6 00	PONY	R, B	C	36	40	23
25 02 3 00	KRAVIČKA	R, B	C	38	40	26

PANDA LADY



Artik. číslo	Názov	Materiál	Povrchová úprava	☐	!	☐
25 01 1 00	PANDA	R, B	C	38	40	23
25 01 4 00	LADY	R, B	C	43	48	23

MAČKA TIGER



Artik. číslo	Názov	Materiál	Povrchová úprava	☐	!	☐
25 00 2 00	MAČKA	R, B	C	30	48	23
25 01 2 00	TIGER	R, B	C	43	48	23

SLON HROCH



Artik. číslo	Názov	Materiál	Povrchová úprava	☐	!	☐
25 00 4 00	SLON	R, B	C	47	37	24
25 01 0 00	HROCH	R, B	C	35	45	23

SLONÍK S LOPTOU MYŠKA



NOVINKA

Artik. číslo	Názov	Materiál	Povrchová úprava	☐	!	☐
25 00 0 13	SLONÍK S LOPTOU	R, S	C	46	52	23
25 00 0 11	MYŠKA	R, S	C	50	51	24

TUČNIAK MALÝ TUČNIAK



NOVINKA

Artik. číslo	Názov	Materiál	Povrchová úprava	☐	!	☐
25 00 0 14	TUČNIAK MALÝ	R, S	C	39	29	24
25 02 0 00	TUČNIAK	R, B	C	29	39	24

SLIMÁK RYBA



Artik. číslo	Názov	Materiál	Povrchová úprava	☐	!	☐
25 00 3 00	SLIMÁK	R, B	C	42	47	23
04 00 2 00	RYBA	R, B	C	50	36	24

VIVA, VIVA K ROTANA



Artik. číslo	Názov	Materiál	Povrchová úprava	∅	h
04 46 x xx	VIVA	Zn, W	Ms, Nim + buk lak, dub lak, jelša	29	34
04 44 x xx	VIVA K	Zn, S, W	Ms, Nim + buk lak, dub lak, jelša	29	40
04 48 x xx	ROTANA	S, W	Cr + buk lak	27	35

COMBI D



Artik. číslo	Názov	Materiál	Povrchová úprava	∅	h
23 15 1 xx	COMBI D	W, S	buk lak., borovica lak.	30	30

S1



Artik. číslo	Názov	Materiál	Povrchová úprava	∅	h
23 27 0 00	S1	W	buk	33	27

CORDOBA



Artik. číslo	Názov	Materiál	Povrchová úprava	∅	h
23 10 1 xx	CORDOBA	W, S	lak- buk, borovica, dub, čerešňa	32	28

NOVONA



Artik. číslo	Názov	Materiál	Povrchová úprava	∅	h
23 03 0 xx	NOVONA	W	borovica	37	39

ECO



Artik. číslo	Názov	Materiál	Povrchová úprava	∅	h
23 02 7 21	ECO	W, S	borovica	26	33
23 02 7 20	ECO malý	W	borovica	23	24

ALPIN



Artik. číslo	Názov	Materiál	Povrchová úprava	∅	h
23 12 0 xx	ALPIN	W	buk	31	36

PD 3



Artik. číslo	Názov	Materiál	Povrchová úprava	∅	h
23 20 0 01	PD 3	W	borovica	39	29

AACHEN



Artik. číslo	Názov	Materiál	Povrchová úprava	∅	h
23 11 1 xx	AACHEN malý	W	buk, orech, mahagón, biela, čierna	28	32
23 11 0 xx	AACHEN	W	buk, biela, orech, mahagón, čierna	34	34

S 3



Artik. číslo	Názov	Materiál	Povrchová úprava	∅	h
23 26 0 00	S 3	W	buk	39	29

VIVIANA



Artik. číslo	Názov	Materiál	Povrchová úprava	∅	h
23 28 0 xx	VIVIANA	W, S	buk lak, čerešňa	30	29

CASIO



Artik. číslo	Názov	Materiál	Povrchová úprava	∅	h
23 10 8 xx	CASIO	W, S	buk, buk lak.	36	28

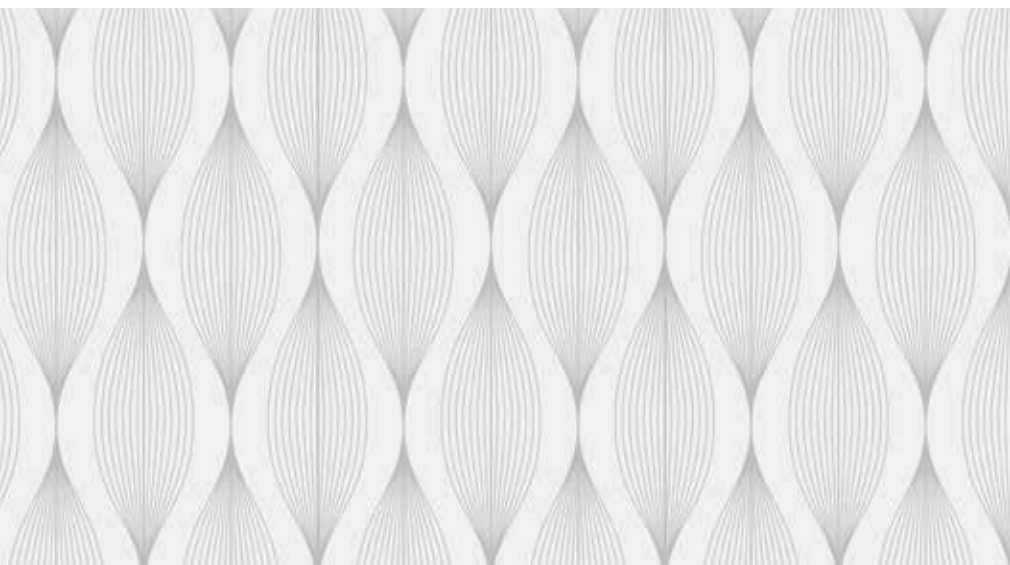

VEŠIAKY
HANGERS

CAMEL I.



Artik. číslo	Názov	Materiál	Povrchová úprava	—	!	—	⊕	⊕
29 34 x 00	CAMEL I.	Zn	Cr, Ms, Crm, Nim	148	78	65	32	

CAMEL II.



Artik. číslo	Názov	Materiál	Povrchová úprava	—	!	—	⊕	⊕
29 35 x 00	CAMEL II.	Zn	Cr, Ms, Crm, Nim	58	78	32	32	

LAMA I.



Artik. číslo	Názov	Materiál	Povrch. úprava	—	!	—	⊕	⊕
29 23 x 00	LAMA I.	Zn	Cr, Crm, Nim, pat na Ms	153	76	54	32	

LAMA II.



Artik. číslo	Názov	Materiál	Povrch. úprava	—	!	—	⊕	⊕
29 24 x 00	LAMA II.	Zn	Cr, Crm, Nim, pat na Ms	57	76	30	32	

ROMANA I.



Artik. číslo	Názov	Materiál	Povrchová úprava	—	!	—	⊕	⊕
29 32 x 00	ROMANA I.	Zn	Cr, Ms, Crm, Nim, pat na Ms, žNi, pat brús.	125	78	77	20	

ROMANA II.



Artik. číslo	Názov	Materiál	Povrchová úprava	—	!	—	⊕	⊕
29 33 x 00	ROMANA II.	Zn	Cr, Ms, Crm, Nim, pat na Ms, žNi, pat brús.	47	78	30	20	

ROMERO I.



Artik. číslo	Názov	Materiál	Povrchová úprava	—	!	—	⊕	⊕
29 30 x 00	ROMERO I.	Zn	Cr, Ms, Crm, Nim, pat na Ms,	165	72	72	32	

ROMERO II.



Artik. číslo	Názov	Materiál	Povrchová úprava	—	!	—	⊕	⊕
29 31 x 00	ROMERO II.	Zn	Cr, Ms, Crm, Nim, pat na Ms	32	58	29	18	

EXCEL I.



Artik. číslo	Názov	Materiál	Povrchová úprava	—	!	—	⊕	⊕
29 28 x xx	EXCEL I.	Zn	Cr, Crm, li	155	25	67	32	

EXCEL II.



Artik. číslo	Názov	Materiál	Povrchová úprava	—	!	—	⊕	⊕
29 28 x xx	EXCEL II.	Zn	Cr, Crm, li	67	25	67	32	

GREGOR I.



Artik. číslo	Názov	Materiál	Povrch. úprava	—	!	—	⊕
29 25 x 0x	GREGOR I.	Zn	Cr,Crm, li	130	20	58	16

GREGOR II.



Artik. číslo	Názov	Materiál	Povrchová úprava	—	!	—	⊕
29 25 x 11	GREGOR II.	Zn	Cr,Crm, li	60	20	58	16

ELEGANT I.
ELEGANT II.



Artik. číslo	Názov	Materiál	Povrchová úprava	—	!	—	⊕
29 39 x 00	ELEGANT I.	Zn	Crn, Nim	125	16	70	32
29 40 x 00	ELEGANT II.	Zn	Crn, Nim	66	16	52	32

FEDOR



Artik. číslo	Názov	Materiál	Povrchová úprava	—	!	—	⊕
NEW	FEDOR	Zn	Cr, Crm, Nim, li	83	20	42	16

SEMIR I.



Artik. číslo	Názov	Materiál	Povrch. úprava	—	!	—	⊕
29 56 9 01	SEMIR I.	Zn	li	18	64	150	32

SEMIR II.



Artik. číslo	Názov	Materiál	Povrch. úprava	—	!	—	⊕
29 57 9 01	SEMIR II.	Zn	li	18	47	70	32

MARKS I.



Artik. číslo	Názov	Materiál	Povrch. úprava	—	!	—	⊕
29 58 x 00	MARKS I.	Zn	Nim	20	77	154	16

MARKS II.



Artik. číslo	Názov	Materiál	Povrch. úprava	—	!	—	⊕
29 59 x 00	MARKS II.	Zn	Nim	20	45	52	16

ARROW I.



Artik. číslo	Názov	Materiál	Povrchová úprava	—	!	—	⊕
29 00 0 09	ARROW I.	Zn	Cr, Crm, Nim, li	144	62	40	22

ARROW II.



Artik. číslo	Názov	Materiál	Povrchová úprava	—	!	—	⊕
29 00 0 0x	ARROW II.	Zn	Cr, Crm, Nim, li	72	62	17	22

OBELIX I.



Artik. číslo	Názov	Materiál	Povrchová úprava	—	!	—	⊕	⊕
29 50 x xx	OBELIX I.	Zn	Nim	94	43	147		32

OBELIX II.



Artik. číslo	Názov	Materiál	Povrch. úprava	—	!	—	⊕	⊕
29 51 x xx	OBELIX II.	Zn	Nim	74	30	79,5		32

EDEN I.



Artik. číslo	Názov	Materiál	Povrchová úprava	—	!	—	⊕	⊕
29 52 x 0x	EDEN I.	Zn	Cr, li	76	71	161		25

EDEN II.



Artik. číslo	Názov	Materiál	Povrch. úprava	—	!	—	⊕	⊕
29 53 x 0x	EDEN II.	Zn	Cr, li	76	40	71		25

ANDERSEN



Artik. číslo	Názov	Materiál	Povrch. úprava	—	!	—	⊕	⊕
29 21 9 00	ANDERSEN	Zn	Nim	100	73	105		25

AVION



Artik. číslo	Názov	Materiál	Povrchová úprava	—	!	—	⊕	⊕
29 00 x xx	AVION	Zn	Cr, li, Crm, Nim	75	35	101		18

INAURIS



Artik. číslo	Názov	Materiál	Povrchová úprava	—	!	—	⊕	⊕
29 41 x 0x	INAURIS	Zn	Cr, Ms, Crm, Nim, li	180	60	60		32

RHODOS



Artik. číslo	Názov	Materiál	Povrchová úprava	—	!	—	⊕	⊕
29 26 7 00	RHODOS	P	Cr	75	75	14		64

SOLUN



Artik. číslo	Názov	Materiál	Povrchová úprava	—	!	—	⊕	⊕
29 03 x 00	SOLUN	Zn	Cr, Crm, Nim	19/96	15/13	65/62		-

HELAS



Artik. číslo	Názov	Materiál	Povrchová úprava	—	!	—	⊕	⊕
29 04 7 00	HELAS	Zn, P	Cr	56/25	19/16	131/107		64

TONY



Artik. číslo	Názov	Materiál	Povrch. úprava	—	!	—	⊕
29 00 2 0x	TONY	S	Cr	59	76	90	14

FREDY



Artik. číslo	Názov	Materiál	Povrch. úprava	—	!	—	⊕
29 09 1 1x	FREDY	S	Cr, li	7	59	51	14

PLAZA



NOVINKA

Artik. číslo	Názov	Materiál	Povrch. úprava	—	!	—	⊕
29 01 x 0x	PLAZA	Zn	Cr, li	37	108	63	

IVAN



Artik. číslo	Názov	Materiál	Povrch. úprava	—	!	—	⊕
29 44 9 01	IVAN vešiak sklopný	Zn	li	46	68	88	36

POINT EUROVEA



NOVINKA

Artik. číslo	Názov	Materiál	Povrch. úprava	—	!	—	⊕
29 19 x 0x	POINT	Zn	Cr, li	40	15	60	
29 16 x 0x	EUROVEA	Zn	Cr, li	40	70	60	

CENTRO



NOVINKA

Artik. číslo	Názov	Materiál	Povrch. úprava	—	!	—	⊕
29 15 x 0x	CENTRO	Zn	Cr, li	80	70	92	

ZAKYNTHOS POLUS

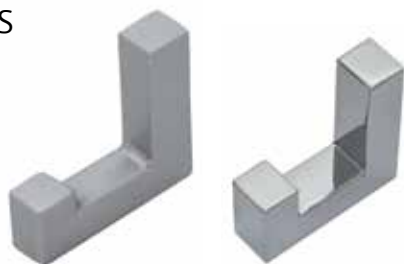

Artik. číslo	Názov	Materiál	Povrchová úprava	—	!	—	⊕
29 27 x 00	ZAKYNTHOS	Zn	Crn	42	10	44	32
29 00 x 0x	POLUS	Zn	Cr, li	40	12	40	16

EUROPA



Artik. číslo	Názov	Materiál	Povrchová úprava	—	!	—	⊕
29 00 x 0x	EUROPA	Zn	Cr, li	52	40	40	16

DAMIAN



Artik. číslo	Názov	Materiál	Povrchová úprava	∅	—	!	⊕
29 42 x 00	DAMIAN	Zn	Cr, Ms, Crn, Nim	18/25	47		

RONALD



NOVINKA

Artik. číslo	Názov	Materiál	Povrchová úprava	—	!	—	⊕
	RONALD	Zn	Cr, li	50	53	35	13

DUO DUO MINI



Artik. číslo	Názov	Materiál	Povrchová úprava	—	!	—	⊕
09 12 x xx	DUO	S	Cr, Ni, Ni, biela, hnedá čierna	155	62	40	36
09 13 x xx	DUO MINI	S	Cr, Ni, Ni, biela, hnedá čierna	85	65	35	36

MONO MONO MINI



Artik. číslo	Názov	Materiál	Povrchová úprava	—	!	—	⊕
09 10 x xx	MONO	S	Cr, Ni, Ni, biela, hnedá, čierna	155	33	45	20
09 11 x xx	MONO MINI	S	Cr, Ni, Ni, biela, hnedá, čierna	72	33	45	20

MONO D MONO MINI D



Artik. číslo	Názov	Materiál	Povrchová úprava	—	!	—	⊕
09 16 9 00	MONO D	S + W	Nim + buk lak	160	33	65	20
09 17 9 00	MONO MINI D	S + W	Nim + buk lak	82	33	51	20

KOTVA KOTVA Zn



Artik. číslo	Názov	Materiál	Povrchová úprava	—	!	—	⊕
09 27 8 xx	KOTVA	S	C	65	51	59	36
09 97 8 31	KOTVA Zn	Zn	Cr	74	75	38	32

MONO FIT



Artik. číslo	Názov	Materiál	Povrchová úprava	—	!	—	⊕
10 48 8 3x	MONO FIT	S	Cr, Ni, Ni	155	10	62	32

FIT VEĽKÝ FIT MALÝ



Artik. číslo	Názov	Materiál	Povrchová úprava	—	!	—	⊕
09 03 x xx	FIT VEĽKÝ	S	Cr, Ms, Cr, Ni, Ni	225	12	65	-
09 03 8 38	FIT VEĽKÝ 170	S	Cr	170	12	65	-
09 08 x xx	FIT MALÝ	S	Cr, Cr, Ni, Ni	70	10	43	32

HÁK



Artik. číslo	Názov	Materiál	Povrchová úprava	∅	!	—	⊕
09 28 x xx	HÁK	S	Cr, Ni, Ni, biela, hnedá čierna	50	10	42	32

EIFEL EIFEL MINI



Artik. číslo	Názov	Materiál	Povrchová úprava	—	!	—	⊕
09 05 x xx	EIFEL	S	Ni, biela, hnedá čierna	150	43	56	25
09 04 x xx	EIFEL MINI	S	Ni, biela, hnedá čierna	60	43	31	25

VEŠIAK VEĽKÝ VEŠIAK MALÝ



Artik. číslo	Názov	Materiál	Povrchová úprava	—	!	—	⊕
09 07 x xx	VEŠIAK VEĽKÝ	S	Cr, Ni, Ni, biela, hnedá, čierna	125	17	74	22
09 06 x xx	VEŠIAK MALÝ	S	Cr, Ni, Ni, biela, hnedá, čierna	29	22	25	10

SAMOLEPIACI VEŠIAK ŠTVOREC



NOVINKA

Artik. číslo	Názov	Materiál	Povrchová úprava	—	!	—
29 09 0 05	Vešiak samolepiaci štvorec	S	li	35	35	18
-	Vešiak samolepiaci s obrázkom	S	li	40	40	20

SAMOLEPIACI VEŠIAK TROJHÁČIK



NOVINKA

Artik. číslo	Názov	Materiál	Povrchová úprava	—	!	—
29 09 0 06	Vešiak samolepiaci 3-háčik	S	C	25	120	18
29 09 0 07	Vešiak samolepiaci 4-háčik	S	C	25	160	18

VÝSUVNÝ VEŠIAK N



Artik. číslo	Názov	Materiál	Povrchová úprava	—	!	—	⊕	⊕
29 46 7 xx	VÝSUVNÝ VEŠIAK N	S,P	Ni, čierna	250 - 500	44	57	32	

GRANADA



Artik. číslo	Názov	Materiál	Povrchová úprava	—	!	—	⊕	⊕
10 13 8 xx	GRANADA Ø 10	S	C	360	230	78	350	

MERAN M FIT Q



Artik. číslo	Názov	Materiál	Povrchová úprava	—	!	—	⊕	⊕
10 13 8 xx	MERAN M Ø 13	S	C	225	13	78	-	
10 10 8 xx	FIT Q 15x15	S	C	221	15	78	-	

SAMOLEPIACI VEŠIAK OKRÚHLÝ, 2ks



NOVINKA

Artik. číslo	Názov	Materiál	Povrchová úprava	—	!	—
29 09 0 04	Vešiak samolepiaci okrúhly	S	C	35	35	18

VEŠIAK NA KRAVATY



Artik. číslo	Názov	Materiál	Povrchová úprava	—	!	—	⊕	⊕
29 45 1 00	VEŠIAK NA KRAVATY	S	Ni	180	59	62	14	

VÝSUVNÝ VEŠIAK PH



Artik. číslo	Názov	Materiál	Povrchová úprava	—	!	—	⊕	⊕
29 45 7 xx	VÝSUVNÝ VEŠIAK PH	S,P	Ni, čierna	250 - 500	44	57	32	

GRANADA Q



Artik. číslo	Názov	Materiál	Povrchová úprava	—	!	—	⊕	⊕
10 12 8 xx	GRANADA Q 15x15	S	C	364	232	80	349	

DALI



Artik. číslo	Názov	Materiál	Povrchová úprava	—	!	—	⊕	⊕
29 02 9 67	DALI	Zn	Nim	230	10	70	-	

BONAPART



Artik. číslo	Názov	Materiál	Povrchová úprava	—	!	—	⊕	⊕
29 11 x 01	BONAPART	Zn	Ms, pat	110	57	96	27	

LONG JOHN



Artik. číslo	Názov	Materiál	Povrchová úprava	—	!	—	⊕	⊕
29 11 x 00	LONG JOHN	Zn	Ms, pat	110	49	69	27	

JOHN



Artik. číslo	Názov	Materiál	Povrchová úprava	—	!	—	⊕	⊕
29 11 x 04	JOHN	Zn	Ms, pat	70	39	72	24	

LITTLE JOHN



Artik. číslo	Názov	Materiál	Povrchová úprava	—	!	—	⊕	⊕
29 11 x 06	LITTLE JOHN	Zn	Ms, pat	44	39	39	24	

OLDO



Artik. číslo	Názov	Materiál	Povrchová úprava	—	!	—	⊕	⊕
29 11 x 03	OLDO	Zn	Ni, Ms, pat	125	32	105	22/28	

SCARABEUS



Artik. číslo	Názov	Materiál	Povrchová úprava	—	!	—	⊕	⊕
29 11 x 17	SCARABEUS	Zn	Ms, pat	60	27	56	16	

FRODO I.



Artik. číslo	Názov	Materiál	Povrch. úprava	—	!	—	⊕	⊕
29 54 x xx	FRODO I.	Zn	Nim, Pat na Ms, Te	68	76	157	32	

FRODO II.



Artik. číslo	Názov	Materiál	Povrch. úprava	—	!	—	⊕	⊕
29 55 x 00	FRODO II.	Zn	Nim, Pat na Ms, Te	68	46	75	32	

PAZÚR PAZÚRIK



Artik. číslo	Názov	Materiál	Povrchová úprava	∅	—	!	—	⊕	⊕
29 11 x 08	PAZÚR	Zn	Ms, pat	24	-	48	-		
29 11 x 09	PAZÚRIK	Zn	Ms, pat	20	-	33	-		

MARCO I. MARCO II.



Artik. číslo	Názov	Materiál	Povrchová úprava	—	!	—	⊕	⊕
29 00 x xx	MARCO I.	Zn	G	44	15	33	-	
29 00 x xx	MARCO II.	Zn	G	35	12	28	-	

BIG LION



Artik. číslo	Názov	Materiál	Povrchová úprava	—	!	—	⊕	⊖
29 11 x 15	BIG LION	Zn	Ms, pat	205	70	60		32

LION



Artik. číslo	Názov	Materiál	Povrchová úprava	—	!	—	⊕	⊖
29 11 x 13	LION	Zn	Ms, pat	110	75	25		32

ĽUDOVÍT



Artik. číslo	Názov	Materiál	Povrchová úprava	—	!	—	⊕	⊖
29 11 x 02	ĽUDOVÍT	Zn	Ms, pat	146	60	70		28

RUDOLF



Artik. číslo	Názov	Materiál	Povrchová úprava	—	!	—	⊕	⊖
29 11 x 10	RUDOLF	Zn	Ms, pat	99	57	19		30

KATY



Artik. číslo	Názov	Materiál	Povrchová úprava	—	!	—	⊕	⊖
29 11 x 11	KATY	Zn	Ms, pat	55	58	19		24

KOLO



Artik. číslo	Názov	Materiál	Povrchová úprava	⊙	—	—	⊕	⊖
29 11 x 07	KOLO	Zn	Ms, pat	36	40	40		28

ĽALIA



Artik. číslo	Názov	Materiál	Povrchová úprava	—	!	—	⊕	⊖
29 11 x 05	ĽALIA	Zn	Ms, pat	80	55	15		30

MAGDALENA



Artik. číslo	Názov	Materiál	Povrchová úprava	—	!	—	⊕	⊖
29 11 x 16	MAGDALENA	Zn	Ms, pat	220	32	40		200

GIULLIO



Artik. číslo	Názov	Materiál	Povrchová úprava	—	!	—	⊕	⊖
29 43 x 0x	GIULLIO	Zn	pat na Ms, Te	174	48	59		32

FLORIAN



Artik. číslo	Názov	Materiál	Povrch. úprava	—	!	—	⊕	⊖
29 09 9 91	FLORIAN	Zn	Pat na Ms	228	31	76		138

IGOR



Artik. číslo	Názov	Materiál	Povrchová úprava	—	!	—	⊕	⊕
29 00 0 04	IGOR	S	Cr	197	40	29	145	

BRANO



Artik. číslo	Názov	Materiál	Povrch. úprava	—	!	—	⊕	⊕
29 45 1 01	BRANO 3-HÁČIK	Al	Al	217	60	40	185	
29 45 1 02	BRANO 4-HÁČIK	Al	Al		60	40		
29 45 1 03	BRANO 5-HÁČIK	Al	Al		60	40		

DREVES BOROVICA



NOVINKA

Artik. číslo	Názov	Materiál	Povrchová úprava	—	!	—	⊕	⊕
29 09 0 17	DREVES 3 borovica	W,Zn	borovica,G	300	45	15	253	
29 09 0 18	DREVES 4 borovica	W,Zn	borovica,G	400	45	15	353	
29 09 0 19	DREVES 5 borovica	W,Zn	borovica,G	500	45	15	453	

DREVES ORECH



NOVINKA

Artik. číslo	Názov	Materiál	Povrchová úprava	—	!	—	⊕	⊕
29 09 0 14	DREVES 3 orech	W,Zn	orech,G	300	45	15	253	
29 09 0 15	DREVES 4 orech	W,Zn	orech,G	400	45	15	353	
29 09 0 16	DREVES 5 orech	W,Zn	orech,G	500	45	15	453	

DEKORAČNÉ VEŠIAKY (zmena farieb a tvarov vyhradená podľa aktuálnej ponuky)

NOVINKA





DVEROVÉ KOVANIE
DOOR FITTINGS

804



funkcia	72	90	2 časti
DOZ	14 06 3 07	14 06 3 00	-
FAB	14 06 3 08	14 06 3 01	-
g-kl	-	14 06 3 11	-

AL



funkcia	72	90	2 časti
DOZ	13 26 0 18	13 26 1 12	-
FAB	13 26 0 17	13 26 1 11	-
g-kl	-	13 26 1 13	-

ELEGANT



funkcia	72	90	2 časti
DOZ	14 13 x 72	14 13x 00	-
FAB	14 13 x 17	14 13 x 10	-
WC	-	14 13 x 83	-
g-kl	-	14 13 x 14	-

BRATISLAVA



funkcia	72	90	2 časti
DOZ	14 95 x 72	14 95 x 00	-
FAB	14 95 x 70	14 95 x 10	-
WC	14 95 x 83	14 95 x 84	-
g-kl	14 95 x 15	14 95 x 14	-

PETRA



funkcia	72	90	2 časti
DOZ	14 23 6 01	14 23 6 00	14 23 6 04
FAB	14 23 6 08	14 23 6 07	14 23 6 06
WC	14 23 6 03	14 23 6 02	14 23 6 05

NATÁLIA



funkcia	72	90	2 časti
DOZ	14 16 9 01	14 16 9 00	14 16 9 04
FAB	14 16 9 08	14 16 9 07	14 16 9 06
WC	14 16 9 03	14 16 9 02	14 16 9 05
g-kl	14 16 9 10	14 16 9 09	-

SYDNEY



funkcia	72	90	2 časti
DOZ	14 18 6 01	14 18 6 00	14 18 x 04
FAB	14 18 6 08	14 18 6 07	14 18 6 06
WC	14 18 6 03	14 18 6 02	14 18 x 05
g-kl	14 18 6 10	14 18 6 09	14 18 6 11

VELA 6000



funkcia	72	90	2 časti
DOZ	14 58 x 72	14 58 x 01	14 58 x 00
FAB	14 58 x 17	14 58 x 11	14 58 x 10
WC	14 58 x 15	-	14 58 x 16

ROMA



funkcia	72	90	2 časti
DOZ	14 19 x 01	14 19 x 00	14 19 x 04
FAB	14 19 x 08	14 19 x 07	14 19 x 06
WC	14 19 x 03	14 19 x 02	14 19 x 05
g-kl	14 19 x 10	14 19 x 09	-

ELA



funkcia	72	90	2 časti
DOZ	14 11 0 30	14 11 0 20	14 11 0 37
FAB	14 11 0 29	14 11 0 22	-
g-kl	-	-	-

KLASIK



funkcia	72	90	2 časti
DOZ	14 90 0 03,05	14 90 0 01,02	14 90 0 10,22
FAB	14 90 0 04,06	14 90 0 00,08	14 90 0 10,22
WC	-	-	14 90 0 09,13
g-kl	-	-	14 90 0 20,21
g-g	-	-	14 90 0 11,12

TOM



funkcia	72	90	kľučka + rozeta
DOZ	-	-	24 35 x 17 24 09 x 22
FAB	-	-	24 35 x 17 24 09 x 23
WC	-	-	24 35 x 17 24 09 x 24

MADERA



NOVINKA

funkcia	72	90	2 časti
DOZ			24 52 x 01
FAB			24 52 x 02
WC			24 52 x 03

ARIA II



NOVINKA

funkcia	72	90	2 časti
DOZ			24 57 x 01
FAB			24 57 x 02
WC			24 57 x 03

QUBIK



NOVINKA

funkcia	72	90	2 časti
DOZ			24 53 x 01
FAB			24 53 x 02
WC			24 53 x 03

NERO

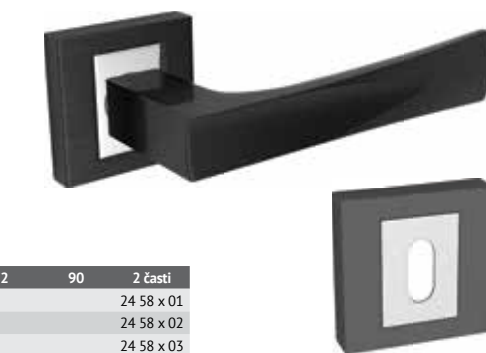

NOVINKA

funkcia	72	90	2 časti
DOZ			24 58 x 01
FAB			24 58 x 02
WC			24 58 x 03

LUX



funkcia	72	90	2 časti
DOZ	14 10 x 47	14 10 x 40	14 10 x 50
FAB	14 10 x 48	14 10 x 41	14 10 x 51
WC	14 10 x 45	14 10 x 49	14 10 x 52
g-kl	14 10 x 46	14 10 x 44	-

BEZPEČNOSTNÉ KOVANIE



funkcia	72	90	2 časti
FAB	-	14 11 3 01	-
g-kl	-	14 11 3 02	-

BEZPEČNOSTNÉ KOVANIE



funkcia	72	90	2 časti
FAB	-	14 11 3 01	-
g-kl	-	14 11 3 02	-

POISTNÁ RETIAZKA



Artik. číslo	Názov	Materiál	Povrchová úprava
14 01 x 00	POISTNÁ RETIAZKA	S	Ms,Cr,Pat

BEZPEČNOSTNÉ KOVANIE



funkcia	72	90	2 časti
FAB	-	14 11 3 01	-
g-kl	-	14 11 3 02	-

BEZPEČNOSTNÉ KOVANIE



funkcia	72	90	2 časti
FAB	-	14 10 2 79	-
g-kl	-	14 10 2 78	-

BEZPEČNOSTNÉ KOVANIE OS1



funkcia	72	90	2 časti
FAB	-	14 11 3 01	-
g-kl	-	14 11 3 02	-

PRÍDAVNÝ ZÁMOK



Artik. číslo	Názov	Materiál
14 05 9 02	PRÍDAVNÝ ZÁMOK	S,P

804 POLOLIVA



Artik. číslo	Názov
14 06 3 05	804 pololiva

804 BALKÓN



Artik. číslo	Názov
14 06 3 02	804 balkón

AL POLOLIVA



Artik. číslo	Názov
14 26 0 83	AL pololiva

AL BALKÓN



Artik. číslo	Názov
14 26 0 94	AL balkón

ELEGANT POLOLIVA



Artik. číslo	Názov
15 13 x 05	ELEGANT pololiva

804 OLIVA



Artik. číslo	Názov
14 06 3 04	804 oliva

804 ROZVORA



Artik. číslo	Názov
14 06 3 03	804 rozvora

AL OLIVA



Artik. číslo	Názov
14 26 0 81	AL oliva

AL ROZVORA



Artik. číslo	Názov
14 26 0 87	AL rozvora

ELEGANT OLIVA



Artik. číslo	Názov
15 13 x 06	ELEGANT oliva 5086

ELEGANT BALKÓN



Artik. číslo	Názov
15 13 x 01	ELEGANT balkón 6084

ELA POLOLIVA



Artik. číslo	Názov
15 11 0 21	ELA pololiva

KLASIK OLIVA



Artik. číslo	Názov
15 90 0 x2	KLASIK oliva

LUX POLOLIVA



Artik. číslo	Názov
14 10 x 53	LUX pololiva

LUX BALKÓN



Artik. číslo	Názov
14 10 x 56	LUX balkón

ELEGANT ROZVORA



Artik. číslo	Názov
15 13 x 05	ELEGANT rozvora 1355

KLASIK POLOLIVA



Artik. číslo	Názov
15 90 0 x1	KLASIK pololiva

KLASIK ROZVORA



Artik. číslo	Názov
15 90 0 x3	KLASIK rozvora

LUX OLIVA



Artik. číslo	Názov
14 10 x 54	LUX oliva

LUX ROZVORA



Artik. číslo	Názov
14 10 x 55	LUX rozvora

HERMINA



funkcia	72	90	2 časti
DOZ	NEW	NEW	-
FAB	NEW	NEW	-

EVELINA



funkcia	72	90	2 časti
DOZ	14 25 5 03	14 25 5 00	-
FAB	14 25 5 02	14 25 5 01	-

HERMINA



funkcia	72	90	2 časti
DOZ	-	-	NEW
FAB	-	-	NEW

EVELINA



funkcia	72	90	2 časti
DOZ	-	-	NEW
FAB	-	-	NEW

RUKOVÄŤ KOVANÁ 136



Artik. číslo	Názov	Materiál	Povrchová úprava	192	38	45	156
14 25 5 09	Rukoväť KOVANÁ 136	P	C				

RUKOVÄŤ KOVANÁ 156



Artik. číslo	Názov	Materiál	Povrchová úprava	152	25	45	138
14 25 5 10	Rukoväť KOVANÁ 156	P	čierna				

LÝDIA



funkcia	72	90	2 časti
DOZ	14 11 0 72	14 11 0 71	-
FAB	14 11 0 73	14 11 0 74	-

VHOZ ŽELEZO



Artik. číslo	Názov	Materiál	Povrchová úprava	285	85	275/75
14 20 6 25	VHOZ ŽELEZO	S	čierna			

ROMAN



Artik. číslo	Názov	Materiál	Povrchová úprava	225	75	275	
-	ROMAN	S	čierna				

JOACHYM



Artik. číslo	Názov	Materiál	Povrchová úprava	225	75	275	
-	JOACHYM	S	čierna				

FLORA I



NOVINKA

Artik. číslo	Názov	Materiál	Povrchová úprava	25	8	32	
14 00 5 63	FLORA I	S	hnedá				

FLORA II



NOVINKA

Artik. číslo	Názov	Materiál	Povrchová úprava	36	8	295	
14 00 6 54	FLORA II	S	hnedá				

RONDO I



NOVINKA

Artik. číslo	Názov	Materiál	Povrchová úprava	25	8	32	
14 00 6 55	RONDO I	S	hnedá				

RONDO II



NOVINKA

Artik. číslo	Názov	Materiál	Povrchová úprava	36	8	295	
14 00 6 56	RONDO II	S	hnedá				

TATU I



NOVINKA

Artik. číslo	Názov	Materiál	Povrchová úprava	25	8	32	
14 00 5 61	TATU I	S	Zn				

TATU II



NOVINKA

Artik. číslo	Názov	Materiál	Povrchová úprava	36	8	295	
14 00 5 62	TATU II	S	Zn				

NZ 45



Artik. číslo	Názov	Materiál	Povrchová úprava	100	150	200	250
-	NZ 45	Zn	G	-	-	45	-

NB 125



Artik. číslo	Názov	Materiál	Povrchová úprava	100	150	200	250
14 00 4 1x	NB 125	Zn	G	-	-	125	-

ČÍSLICA 100



Artik. číslo	Názov	Materiál	Povrchová úprava	100	150	200	250
14 00 4 3x	ČÍSLICA 100	Zn	G	-	-	100	-

NZ 75



Artik. číslo	Názov	Materiál	Povrchová úprava	100	150	200	250
14 00 4 0x	NZ 75	P	G	-	-	75	-

ČÍSLO 15 CM



NOVINKA

Artik. číslo	Názov	Materiál	Povrchová úprava	100	150	200	250
14 00 2 15	ČÍSLO 15CM	W	C	-	-	150	-

MTG 152



Artik. číslo	Názov	Materiál	Povrchová úprava	100	150	200	250
14 00 4 2x	MTG 152	Zn	G	-	-	125	-

ČÍSLO 5 CM



NOVINKA

Artik. číslo	Názov	Materiál	Povrchová úprava	100	150	200	250
14 00 1 05	ČÍSLO 5 CM TMAVÉ	W	hnedá	-	-	50	-

ČÍSLO 10 CM



NOVINKA

Artik. číslo	Názov	Materiál	Povrchová úprava	100	150	200	250
14 00 1 07	ČÍSLO 10 CM TMAVÉ	W	hnedá	-	-	100	-

PIKTOGRAM NEREZ



Artik. číslo	Názov	Materiál	Povrchová úprava	100	150	200	250
14 00 9 01	PIKTOGRAM NEREZ 100 x 100	S	li	100	100	-	-

PIKTOGRAM NEREZ



Artik. číslo	Názov	Materiál	Povrchová úprava	100	150	200	250
-	PIKTOGRAM NEREZ 150 x 150	S	li	150	150	-	-

DREVENÉ PIKTOGRAMY A MENOVKY



Artik. číslo	Názov	Materiál	Povrchová úprava				
14 00 x xx	DREVENÉ PIKTOGRAMY	W	-	-	-	-	-

VHOZ



Artik. číslo	Názov	Materiál	Povrchová úprava				
14 00 x 60	VHOZ	B	G	250	75		235

VHOZ NEREZ



Artik. číslo	Názov	Materiál	Povrchová úprava				
-	VHOZ NEREZ	I	I	310	90		

VHOZ PLAST



Artik. číslo	Názov	Materiál	Farba				
-	VHOZ PLAST	P	čierna,biela	340	80	10	x

VHOZ KARTÁČ



Artik. číslo	Názov	Materiál	Farba				
-	VHOZ KARTÁČ	P	čierna,biela	340	80	10	x

DVEROVÁ ZÁSTRČ



Artik. číslo	Názov	Materiál	Povrchová úprava				
13 14 0 xx	ZÁSTRČ	S	Zn	410			

DVEROVÁ ZARÁŽKA



Artik. číslo	Názov	Materiál	Povrchová úprava				
13 14 0 xx	ZARÁŽKA	S	Zn	400			

DVEROVÁ ZARÁŽKA



Artik. číslo	Názov	Materiál	Povrchová úprava	∅	l	⊕	⊖
14 01 1 75	DVEROVÁ ZARÁŽKA	S,R	Zn, biela, hnedá	220	-		

MENOVKA 87



Artik. číslo	Názov	Materiál	Povrchová úprava	∅	l	⊕	⊖
14 20 x 20	MENOVKA 87	Zn	Ms, hn	120	47	5	110

KUKÁTKO PANORAMA 180°



Artik. číslo	Názov	Materiál	Povrchová úprava	∅	l
14 01 x 80	KUKÁTKO PANORAMA 180°	B	G	14	41
14 01 1 8x	PODLOŽKA POD KUKÁTKO	B	G	46	-

KLOPADLO ANFORA



Artik. číslo	Názov	Materiál	Povrchová úprava	∅	l	⊕	⊖
14 07 x 0x	KLOPADLO ANFORA	B	G	-	78	155	-

DRŽIAK SCHODIŠŤOVÉHO ZÁBRADLIA



Artik. číslo	Názov	Materiál	Povrchová úprava	∅	l	⊕	⊖
50 18 x 00	Držiak schodišťového zábradlia I.	B	G	53	75	20	
50 18 0 0x	Držiak schodišťového zábradlia II.	Zn	G	55	79	30	

STAVAČ DVERÍ SH 102



Artik. číslo	Názov	Materiál	Povrchová úprava	∅	l	⊕	⊖
14 00 x 28	STAVAČ DVERÍ SH 102	B	G	45	-	-	25

DORAZ DVERÍ VALEC



Artik. číslo	Názov	Materiál	Povrchová úprava	∅	l	⊕	⊖
14 00 8 xx	DORAZ DVIER VALEC	Zn	G	31	-	-	40

DORAZ DVERÍ NÍZKY



Artik. číslo	Názov	Materiál	Povrchová úprava	∅	l	⊕	⊖
16 00 0 xx	DORAZ DVIER NÍZKY	S,R	li,Pat	90	-	-	45

DORAZ PLASTOVÝ NA KĽUČKU



Artik. číslo	Názov	Materiál	Povrchová úprava	∅	l	⊕	⊖
16 00 0 04	DORAZ PLASTOVÝ NA KĽUČKU	P	T	45	23	14	

DORAZ DVERÍ VYSOKÝ



Artik. číslo	Názov	Materiál	Povrchová úprava	∅	l	⊕	⊖
14 00 8 0x	DORAZ DVIER VYSOKÝ	S,R	li,Pat	70	-	-	70

ZARÁŽKA DVERÍ KUŽEL'



Artik. číslo	Názov	Materiál	Povrchová úprava	∅	—	⊕
89 00 0 07	ZARÁŽKA DVERÍ KUŽEL'	R	čierna	32	27	-
14 00 8 15	ZARÁŽKA DVERÍ KUŽEL'	R	biela	32	27	-

TLMIČ NÁRAZU SAMOLEPIACI



Artik. číslo	Názov	Materiál	Povrchová úprava	∅	—	!	⊕
16 18 9 34	TLMIČ	R	biela,hnedá,béžová	40	-	-	8

ZÁVES PRUŽINOVÝ



Artik. číslo	Názov	Materiál	Povrch. úprava	—	!	⊕
12 09 x xx	ZÁVES PRUŽINOVÝ	S	Zn, Ni	-	-	75-125

ZÁVES OKENNÝ, DVEROVÝ



Artik. číslo	Názov	Materiál	Povrch. úprava	+	—	⊕
12 11 0 8x	ZÁVES OKENNÝ 80 L, P	S	Zn	2	80	80/91
12 11 0 6x	ZÁVES DVEROVÝ 120 L, P	S	Zn	2	57	133
12 11 0 1x	ZÁVES DVEROVÝ 100 L, P	S	Zn	2	59	112

OKENNÝ JAZÝČEK



Artik. číslo	Názov	Materiál	Povrch. úprava	—	!	⊕
13 06 x 14	OKENNÝ JAZÝČEK	S	Zn	24	14	86 72

ZÁMOK ZADLABÁVACÍ



Artik. číslo	Názov	Materiál	Povrch. úprava	—	!	⊕
13 06 0 08	ZÁMOK ZADLABÁVACÍ	S	Zn	-	60	-

ZÁMOK ZADLABÁVACÍ FAB



Artik. číslo	Názov	Materiál	Povrch. úprava	—	!	⊕
13 06 0 0x	ZÁMOK ZADLABÁVACÍ FAB	S	Zn	-	60/80	72/90

ZÁMOK ZADLABÁVACÍ DOZ



Artik. číslo	Názov	Materiál	Povrch. úprava	—	!	⊕
13 06 0 6x	ZÁMOK ZADLABÁVACÍ DOZ	S	Zn	-	60/80	72/90

VLOŽKA FAB



Artik. číslo	Názov	Materiál	Povrch. úprava	—	!	⊕
13 04 5 xx	VLOŽKA FAB	B	Ms	*	*	*

VISIACE ZÁMKY



Artik. číslo	Názov	Materiál	Povrch. úprava	—	!	⊕
13 13 9 5x	VISIACE ZÁMKY	B, S	Ms, C, Zn	*	*	*

DOBOVÉ KOVANIE

- tovar na objednávku, možnosť výroby podľa dodaného vzoru

OLD FASHION FITTINGS

- goods on the order, possibility of making this product like you can see on the sample

PRESSBURG



TALIAN



SCOT



DOBOVÉ ZÁVESY



DARIA



NOVINKA

Artik. číslo	Název	Materiál	Povrch. úprava	—	!	—
19 60 9 10	STOJAN NA ŠATY DARIA	S, P	grafit	1200	450	1800

MARCO



NOVINKA

Artik. číslo	Název	Materiál	Povrch. úprava	—	!	—
19 60 8 11	STOJAN NA ŠATY MARCO	S, P	Cr. grafit	850 - 1500	440	850 - 1600

ROCCO



NOVINKA

Artik. číslo	Název	Materiál	Povrch. úprava	—	!	—
19 60 8 10	STOJAN NA ŠATY ROCCO	S, P	Cr. grafit	800	420	900 - 1600

ZOSIA



NOVINKA

Artik. číslo	Název	Materiál	Povrch. úprava	—	!	—
19 60 7 35	STOJAN NA ŠATY ZOSIA	S, P	grafit	750	300	1800

TOLA



NOVINKA

Artik. číslo	Název	Materiál	Povrch. úprava	—	!	—
19 60 4 21	STOJAN NA TOPÁNKY TOLA	S, P	grafit	500	25	670

TOLA BIS



NOVINKA

Artik. číslo	Název	Materiál	Povrch. úprava	—	!	—
19 60 4 22	STOJAN NA TOPÁNKY TOLA BIS	S, P	grafit	750	25	850

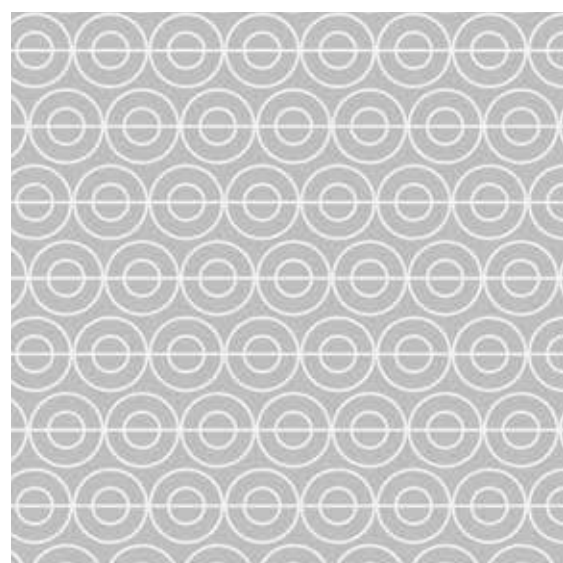
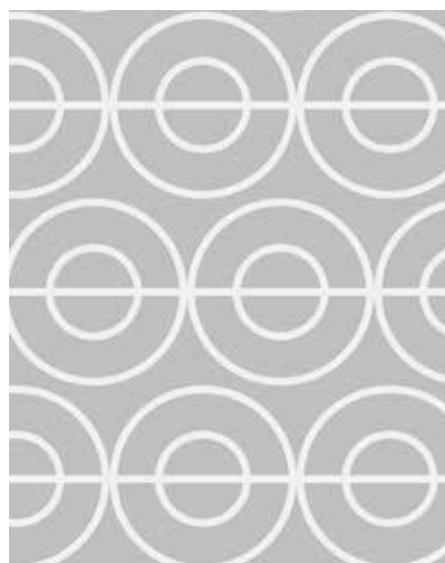
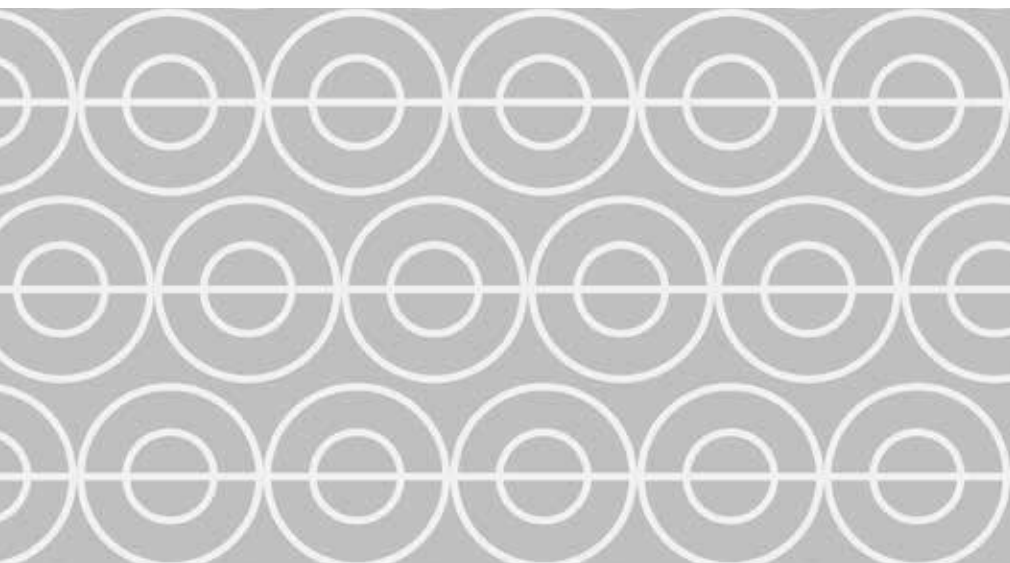

KLZÁKY A NOHY
GLIDERS AND LEGS

ONK 68 P



Artik. číslo	Název	Materiál	Povrch. úprava	∅	┌	└	⊕
07 64 7 10	ONK 68 P	Zn, S, P	C	68	40x40	74	25/25

ONK 68



Artik. číslo	Název	Materiál	Povrch. úprava	∅	┌	└	⊕
07 65 7 10	ONK 68	Zn, S, P	C	68	9	93/60	

KA 50 D42



Artik. číslo	Název	Materiál	Povrch. úprava	∅	┌	└	⊕
27 49 9 52	KA 50 D42	P, S	čierna	50	42x42	42	32/32

KB 50 A8



Artik. číslo	Název	Materiál	Povrch. úprava	∅	┌	└	⊕
27 49 9 50	KB 50 A8	P, S	čierna	50	8	52/32	

KA 50 M8



Artik. číslo	Název	Materiál	Povrch. úprava	∅	┌	└	⊕
27 49 9 11	KA 50 M8	P, S	čierna	50	M8	-	

KA 50 A8



Artik. číslo	Název	Materiál	Povrch. úprava	∅	┌	└	⊕
27 49 9 51	KA 50 A8	P, S	čierna	50	8	-	

226 C



Artik. číslo	Název	Materiál	Povrch. úprava	∅	┌	└	⊕
27 50 0 92	226 C	P	čierna	50/13	-	-	-

KL 43 - SK 72



Artik. číslo	Název	Materiál	Povrch. úprava	∅	┌	└	⊕
27 50 0 90	KL 43 - SK 72	P	čierna	43/13	-	-	25/47

KR 60



Artik. číslo	Název	Materiál	Povrch. úprava	∅	┌	└	⊕
27 56 8 37	KR 60	P	C, Crm, Nim	60	-	-	20
27 57 8 37	KR 60 čap	P	C, Crm, Nim	60/11	-	-	20

KLZÁK REKTIFIKAČNÝ



Artik. číslo	Název	Materiál	Povrch. úprava	∅	┌	└	⊕
27 53 8 91	KLZÁK REKTIFIKAČNÝ 17	P, S	čierna	50	-	-	17
27 53 8 xx	KLZÁK REKTIFIKAČNÝ 27	P, S	C	50	-	-	27

KLZÁK NA SKRUTKU



Artik. číslo	Názov	Materiál	Povrch. úprava	60	40	20	32
61 00 0 54	KLZÁK	P	čierna	priemer50	-	25	-

KLZÁK NA SKRUTKU



Artik. číslo	Názov	Materiál	Povrch. úprava	60	40	20	32
27 50 0 95	KLZÁK NA SKRUTKU	P	čierna	priemer50	-	50	-

KLZÁK SO SKRUTKOU M8



Artik. číslo	Názov	Materiál	Povrch. úprava	60	40	20	32
61 00 1 54	KLZÁK M8	P	čierna	priemer50	-	100	-

KLZÁK PODNOŽE



Artik. číslo	Názov	Materiál	Povrch. úprava	60	40	20	32
27 51 9 xx	KLZÁK 32	P	buk, biela, hnedá, čierna	50	14	4,5	32

KLZÁK 731



Artik. číslo	Názov	Materiál	Povrch. úprava	60	40	20	32
61 05 8 31	KLZÁK 731	P	Crn	60	40	20	32

KLZÁK 724



Artik. číslo	Názov	Materiál	Povrch. úprava	60	40	20	32
61 00 x xx	KLZÁK 724	P	C, Cr, Crm, pat na Ms, Te	60	60	20	32

KLZÁK 734



Artik. číslo	Názov	Materiál	Povrch. úprava	60	40	20	32
61 00 1 01	KLZÁK 734	P	Crn	60	60	10	32

KLZÁK 735



Artik. číslo	Názov	Materiál	Povrch. úprava	60	40	20	32
61 00 2 01	KLZÁK 735	P	Crn	80	30	10	32

KLZÁK NASTRELOVACÍ



Artik. číslo	Názov	Materiál	Povrch. úprava	60	40	20	32
27 50 8 xx	KLZÁK NASTRELOVACÍ	P	buk, biela, hnedá, čierna	38	16	3	-

KR 45x45



Artik. číslo	Názov	Materiál	Povrch. úprava	60	40	20	32
27 55 8 37	KR 45x45	P	C	45	45	25	32

KLZÁK TROJUHOLNÍK



Artik. číslo	Název	Materiál	Povrch. úprava		!	
27 51 8 00	KLZÁK TROJUHOLNÍK 15	P	čierna	57/57	-	15
27 52 8 92	KLZÁK TROJUHOLNÍK 20	P	čierna	57/57	-	20
27 52 8 91	KLZÁK TROJUHOLNÍK 25	P	čierna	57/57	-	25
27 51 8 01	KLZÁK TROJUHOLNÍK 35	P	čierna	57/57	-	35

KLZÁK TROJUHOLNÍK



Artik. číslo	Název	Materiál	Povrch. úprava		!	
27 52 8 xx	KLZÁK TROJUHOLNÍK	P	biela, hnedá, čierna	59/59	80	4

REKTIFIKAČNÁ SKRUTKA



Artik. číslo	Název	Materiál	Povrch. úprava	Ø		!
16 05 0 91	REKTIFIKAČNÁ SKRUTKA M6x25	P, S	čierna	M6/20	-	6/25
16 05 0 92	REKTIFIKAČNÁ SKRUTKA M8x20	P, S	čierna	M8/28	-	8/20
16 05 0 94	REKTIFIKAČNÁ SKRUTKA M10x25	P, S	čierna	M10/32	-	9/25

KLZÁK S KLINCOM



Artik. číslo	Název	Materiál	Povrch. úprava	Ø		!
27 51 2 xx	KLZÁK S KLINCOM Ø 12	P, S	biela	1,8/12	-	4,5/23
27 51 2 xx	KLZÁK S KLINCOM Ø 16	P, S	hnedá	1,8/16	-	5/28

KLZÁK S DVOMA KLINCAMI



Artik. číslo	Název	Materiál	Povrch. úprava		!	
27 51 2 02	KLZÁK S DVOMA KLINCAMI	P, S	čierna	46/33	18	15
27 51 2 01	KLZÁK S DVOMA KLINCAMI	P, S	čierna	45	15	5



KLZÁK S HROTMI



Artik. číslo	Název	Materiál	Povrch. úprava		!	
27 51 9 00	KLZÁK S HROTMI	P	T	49	16	5/17 32

FILCOVÉ PODLOŽKY

NOVINKA

TVAR	ROZMER v mm	POČET kusov na hárku	SKLADOM				
			Č	B	Š	H	K
 obdĺžnik	10x40	24					
	15x100	9					
	15x30	18					
	15x40	18					
	15x80	9					
	16x92	8					
	20x44	14					
	20x80	7					
	25x60	6					
	30x40	8					
	40x20	14					
	45x140	2					
	45x90	3					
	50x100	3					✓
90x140	1						
100x120	1						
100x165	1	✓	✓	✓	✓	✓	
 štvorec	14x14	45	✓	✓	✓	✓	
	15x15	45					
	20x20	28	✓	✓	✓	✓	
	25x25	18					
	28x28	15	✓	✓	✓	✓	
	30x30	15					
	38x38	8	✓	✓	✓	✓	
	40x40	6					
	50x50	3					
	14	45	✓	✓	✓	✓	
	15	45					
	17	32					
	20	28	✓	✓	✓	✓	
	22	24					
25	18						
28	15	✓	✓	✓	✓		
30	15						
35	8						
38	8	✓	✓	✓	✓		
40	6						
45	6						
50	3						
60	2						
70	2						
80	2						



čierna (Č)



biela (B)



šedá (Š)



hnedá (H)



korok (K)

ALU QUADRA 40



Artik. číslo	Názov	Materiál	Povrch. úprava	∅	!	⊕	⊕
16 74 8 xx	ALU QUADRA 40/60	Al, P	Cr, Ni, čierna	40	40	60	32/32
16 75 8 xx	ALU QUADRA 40/100	Al, P	Cr, Ni, čierna	40	40	100	32/32
16 76 8 xx	ALU QUADRA 40/150	Al, P	Cr, Ni, čierna	40	40	150	32/32

ALU QUADRA 60



Artik. číslo	Názov	Materiál	Povrch. úprava	∅	!	⊕	⊕
16 77 8 xx	ALU QUADRA 60/60	Al, P	Cr, Ni, čierna	60	60	60	32/32
16 78 8 xx	ALU QUADRA 60/100	Al, P	Cr, Ni, čierna	60	60	100	32/32
16 79 8 xx	ALU QUADRA 60/150	Al, P	Cr, Ni, čierna	60	60	150	32/32

ALU Ø 60



Artik. číslo	Názov	Materiál	Povrch. úprava	∅	!	⊕	⊕
16 80 8 37	ALU Ø 60/60	Al, P	Cr, Ni	60	60	60	32/32
16 81 8 37	ALU Ø 60/100	Al, P	Cr, Ni	60	60	100	32/32
16 82 8 37	ALU Ø 60/150	Al, P	Cr, Ni	60	60	150	32/32

NOHA REKTIFIKAČNÁ

Ø 28



Artik. číslo	Názov	Materiál	Povrch. úprava	∅	!	⊕	⊕
09 70 8 xx	REKTIFIKAČNÁ Ø 28/72	S, P	C	28	72	40/25	
09 71 8 xx	REKTIFIKAČNÁ Ø 28/100	S, P	C	28	100	40/25	
09 72 8 xx	REKTIFIKAČNÁ Ø 28/150	S, P	C	28	150	40/25	

NOHA KÓNICKÁ



Artik. číslo	Názov	Materiál	Povrch. úprava	∅	!	⊕	⊕
16 28 x xx	NOHA KÓNICKÁ 100 mm	S	Cr, Cr, Ni	25	100	42/42	
16 28 x 12	NOHA KÓNICKÁ 120 mm	S	Cr, Cr, Ni	25	120	42/42	
16 28 x 15	NOHA KÓNICKÁ 150 mm	S	Cr, Cr, Ni	25	150	42/42	
16 28 x 20	NOHA KÓNICKÁ 200 mm	S	Cr, Cr, Ni	25	200	42/42	
16 28 x 30	NOHA KÓNICKÁ 300 mm	S	Cr, Cr, Ni	25	300	42/42	
16 28 3 50	NOHA KÓNICKÁ 500 mm	S	Cr	25	500	42/42	

POPULAR



Artik. číslo	Názov	Materiál	Povrch. úprava	∅	!	⊕	⊕
16 43 x 00	POPULAR 100	S, P	Cr, Cr, Ni, Ni, li	32	100	45/45	
16 43 x 15	POPULAR 150	S, P	Cr, Cr, Ni, Ni, li	32	150	45/45	

REKTIFIKAČNÁ PVC +OBJÍMKA



Artik. číslo	Názov	Materiál	Povrch. úprava	∅	!	⊕	⊕
16 25 1 10	REKTIFIKAČNÁ PVC	P	čierna	27/47	-	-	100-150
16 25 1 30	OBJÍMKA plastová	P	čierna	-	39	36	50

REKTIFIKAČNÁ PVC +OBJÍMKA



Artik. číslo	Názov	Materiál	Povrch. úprava	∅	!	⊕	⊕
16 25 0 10	REKTIFIKAČNÁ PVC 100 mm	P	biela	28/60	-	-	100
16 25 0 12	REKTIFIKAČNÁ PVC 120 mm	P	biela	28/60	-	-	120
16 25 0 30	OBJÍMKA plastová	P	biela	-	41	37	30
16 25 0 40	OBJÍMKA plast + kov	S, P	Zn, biela	-	40	38	51
16 25 0 20	OBJÍMKA kovová	S		-	40	30	55

REKTIFIKAČNÁ Ø 50



Artik. číslo	Názov	Materiál	Povrch. úprava	Ø	—	!	—
09 69 8 xx	REKTIF. Ø 50/72 mm	S, P	C	50	72		58/58
09 68 8 xx	REKTIF. Ø 50/72 mm s imbusom	S, P	C	50	72		58/58
09 65 8 xx	REKTIF. Ø 50/162 mm s imbusom	S, P	C	50	162		58/58

NOHA Ø 50



Artik. číslo	Názov	Materiál	Povrch. úprava	Ø	—	!	—
10 39 x xx	NOHA Ø 50/50 mm	S, P	C	55	50		58/58
10 39 x xx	NOHA Ø 50/110 mm	S, P	C	55	110		58/58

NOHA NASTAVOVACIA



Artik. číslo	Názov	Materiál	Povrch. úprava	Ø	—	!	—
09 71 8 xx	NOHA NASTAVOVACIA Ø 40	S, P	C	40	105-135		42/42

NOHA VALCOVÁ



Artik. číslo	Názov	Materiál	Povrch. úprava	Ø	—	!	—
10 50 8 xx	NOHA VALCOVÁ 80/180 mm	S, P	C	80	-	-	180

NOHA POD SKLO +KRYT



Artik. číslo	Názov	Materiál	Povrch. úprava	Ø	—	!	—
09 50 8 xx	NOHA POD SKLO + KRYT	S	C	28/45	-		100

NOHA 709 R



Artik. číslo	Názov	Materiál	Povrch. úprava	Ø	—	!	—
60 04 8 37	NOHA 709 R	P	Crm	50	-	-	100

NOHA Ø 60/150



Artik. číslo	Názov	Materiál	Povrch. úprava	Ø	—	!	—
16 46 3 15	NOHA Ø 60/150 mm	S, P	Cr	60	-	-	150
*	NOHA Ø 60/ *	S, P	Cr	60	-	-	30-235

NOHA SONATA Ø 40/120



Artik. číslo	Názov	Materiál	Povrch. úprava	Ø	—	!	—
10 00 6 02	NOHA SONATA Ø 40/100 mm	S, P	Cr	40	-	-	100
10 00 4 02	NOHA SONATA Ø 40/120 mm	S, P	Cr	40	-	-	120
16 33 3 15	NOHA SONATA Ø 40/140 mm	S, P	Cr	40	-	-	140
*	NOHA SONATA Ø 40/ *	S, P	Cr	40	-	-	70-220

NOHA 40/40



Artik. číslo	Název	Materiál	Povrch. úprava	□	!	□	⊕
10 58 x xx	NOHA 40x40 SO SKRUTKOU M8	S, P	C, Cr, li	40	40	100	
10 58 x xx	NOHA 40x40 M8	S, P	C, li	40	40	100	

NOHA N 40



Artik. číslo	Název	Materiál	Povrch. úprava	□	!	□	⊕
10 59 8 xx	NOHA N 40/40 mm	S, P	C	40	40	40	45/45
10 57 8 xx	NOHA N 40/100 mm	S, P	C	40	40	100	45/45
10 57 8 xx	NOHA N 40/120 mm	S, P	C	40	40	120	45/45

NOHA N 60

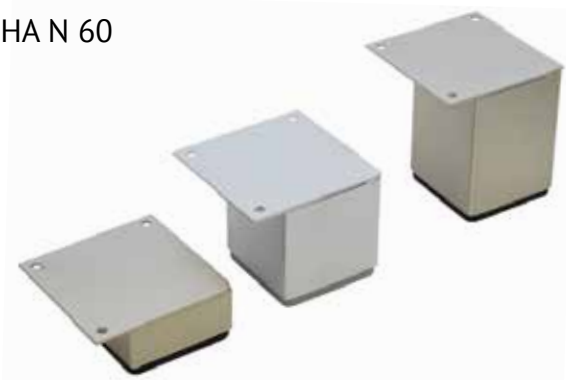

Artik. číslo	Název	Materiál	Povrch. úprava	□	!	□	⊕
10 54 8 xx	NOHA N 60/30 mm	S, P	C	60	60	30	65/65
10 50 8 xx	NOHA N 60/80 mm	S, P	C	60	60	80	65/65
10 50 8 xx	NOHA N 60/100 mm	S, P	C	60	60	100	65/65
10 55 8 xx	NOHA N 60/200 mm	S, P	C	60	60	200	65/65
10 55 8 xx	NOHA N 60/400 mm	S, P	C	60	60	400	65/65

NOHA N 80

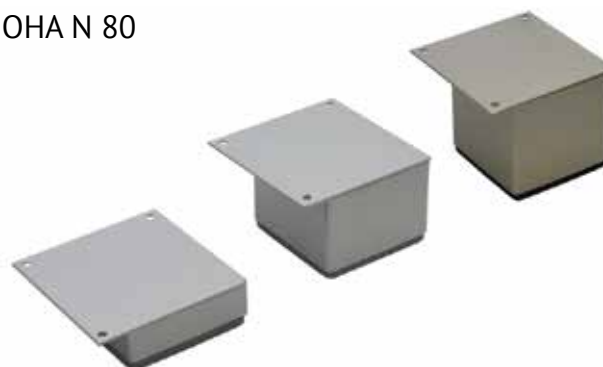

Artik. číslo	Název	Materiál	Povrch. úprava	□	!	□	⊕
10 53 8 xx	NOHA N 80/30 mm	S, P	C	80	80	30	85/85
10 52 8 xx	NOHA N 80/60 mm	S, P	C	80	80	60	85/85
10 52 8 xx	NOHA N 80/80 mm	S, P	C	80	80	80	85/85
10 52 9 xx	NOHA N 80/90 mm	S, P	C	80	80	90	85/85
10 50 8 xx	NOHA N 80/100 mm	S, P	C	80	80	100	85/85

NOHA POSTELE POINT



NOVINKA Dostupné aj v povrchovej úprave antracit (obrázok)

Artik. číslo	Název	Materiál	Povrch. úprava	□	!	□	⊕
09 84 8 3x	NOHA POSTELE POINT	S, P	C	80	80	120	
09 84 8 4x	NOHA POSTELE POINT	S, P	C	80	80	200	
*	NOHA POSTELE POINT	S, P	C	80	80	*	

NOHA 727 R



Artik. číslo	Název	Materiál	Povrch. úprava	□	!	□	⊕
62 52 8 xx	NOHA 727 R 100	P	C	38	38	100	32/32
62 55 8 xx	NOHA 727 R 180	P	C	38	38	180	32/32

NOHA 707 R



Artik. číslo	Název	Materiál	Povrch. úprava	□	!	□	⊕
62 30 x xx	NOHA 707 R	P	Cr, Crm	40	40	100	

NOHA 776 R



Artik. číslo	Název	Materiál	Povrch. úprava	□	!	□	⊕
62 40 x xx	NOHA 776 R	P	Cr, Crm	33	33	100	32/32

NOHA 720



Artik. číslo	Název	Materiál	Povrch. úprava	∅	H
10 xx x 82	SK 154-NOHA 720	P	Cr,m	70	256

NOHA KUŽELOVÁ 761 +UPEVNENIE



Artik. číslo	Název	Materiál	Povrch. úprava	∅	—	!	—	!
62 00 8 37	NOHA KUŽELOVÁ+UPEVNENIE	P	C	50/71	-	-	-	100

KLEMENT



Artik. číslo	Název	Materiál	Povrch. úprava	∅	!	—	!	—	!
16 44 x 00	KLEMENT	Zn,P	Cr, Crm, Nim	48	-	90	40		

TUDOR



Artik. číslo	Název	Materiál	Povrch. úprava	∅	—	!	—	!
16 49 8 xx	TUDOR	Zn,P	Cr, Crm, Nim	54	120	-		

NOHA ŠIKMÁ 4



Artik. číslo	Název	Materiál	Povrch. úprava	∅	—	!	—	!
16 56 x 00	NOHA ŠIKMÁ štvorcová platnička	S,P	Cr, Crm	64	110	45/45		

NOHA ŠIKMÁ 8



Artik. číslo	Název	Materiál	Povrch. úprava	∅	—	!
16 36 x 00	NOHA ŠIKMÁ 8- uholníková platnička	S, P	Cr, Crm	72	60	
16 37 x 00	NOHA ŠIKMÁ 8- uholníková platnička	S, P	Cr, Crm	72	100	
16 38 x xx	NOHA ŠIKMÁ 8- uholníková platnička	S, P	Cr, Crm, Nim	72	130	

NOHA ROHOVÁ



NOVINKA

Artik. číslo	Název	Materiál	Povrch. úprava	∅	—	!	—	!
16 70 3 27	NOHA ROHOVÁ	S,P	Cr	-	127	127	100	

NOHA ROHOVÁ 2



NOVINKA

Artik. číslo	Název	Materiál	Povrch. úprava	∅	—	!	—	!
16 70 3 10	NOHA ROHOVÁ 2 100	S,P	Cr	-	100	100	100	
16 70 3 12	NOHA ROHOVÁ 2 120	S,P	Cr	-	100	100	120	
16 70 3 11	NOHA ROHOVÁ 2 130	S,P	Cr	-	100	100	130	
16 70 3 00	NOHA ROHOVÁ 2 150	S,P	Cr	-	130	130	150	

NOHA LEŽIACA



Artik. číslo	Název	Materiál	Povrch. úprava	∅	—	⊕	⊕
16 59 3 11	NOHA LEŽIACA	S, P	Cr	40	200		
	NOHA LEŽIACA	S, P	Cr	50	250		
	NOHA LEŽIACA	S, P	Cr	60	250		

NOHA LEŽIACA 2



Artik. číslo	Název	Materiál	Povrch. úprava	—	!	—	⊕	⊕
16 59 3 13	NOHA LEŽIACA 2	S	Cr	177	40	20		124

NOHA ZVAR



Artik. číslo	Název	Materiál	Povrch. úprava	∅	—	⊕	⊕
10 65 8 00	NOHA ZVAR ∅ 32	S, P	C	32	41		38
10 66 8 00	NOHA ZVAR ∅ 40	S, P	C	40	49		38

NOHA 704 R



Artik. číslo	Název	Materiál	Povrch. úprava	—	!	—	⊕	⊕
61 20 x xx	NOHA 704 R	S, P	C, Cr, Crm	100	100	25		64/64
62 86 x xx	NOHA 704 R	S, P	C, Cr, Crm	100	100	30		64/64
62 22 x xx	NOHA 704 R	S, P	C, Cr, Crm	100	100	35		64/64
*	NOHA 704 R	S, P	C, Cr, Crm	100	100	45-65		64/64

JAROS



Artik. číslo	Název	Materiál	Povrch. úprava	—	!	—	⊕	⊕
NEW	JAROS	S	C	68	80	115		60

NOHA LEŽIACA HRANATÁ



Artik. číslo	Název	Materiál	Povrch. úprava	—	!	—	⊕	⊕
16 59 3 10	NOHA LEŽIACA HRANATÁ	S, P	Crm	145	40	40		

NOHA 736



Artik. číslo	Název	Materiál	Povrch. úprava	—	!	—	⊕	⊕
NEW	NOHA 736	S, P	Cr, Crm	75	75	20-60		48/48

NOHA 736 R



Artik. číslo	Název	Materiál	Povrch. úprava	—	!	—	⊕	⊕
NEW	NOHA 736 R	S, P	Cr, Crm	75	75	20-60		48/48

NOHA 706 R



Artik. číslo	Názov	Materiál	Povrch. úprava	□	!	□	⊕
61 01 x xx	NOHA 706 R	S, P	C, Cr, Crm	75	75	17	48/48
61 12 x xx	NOHA 706 R	S, P	C, Cr, Crm	75	75	25	48/48
61 13 x xx	NOHA 706 R	S, P	C, Cr, Crm	75	75	30	48/48
*	NOHA 706 R	S, P	C, Cr, Crm	75	75	35-60	48/48

NOHA 706



Artik. číslo	Názov	Materiál	Povrch. úprava	□	!	□	⊕
61 30 x xx	NOHA 706	P	C, Cr, Crm	75	75	17	48/48
61 31 x xx	NOHA 706	P	C, Cr, Crm	75	75	20	48/48
61 36 x xx	NOHA 706	P	C, Cr, Crm	75	75	25	48/48
61 32 x xx	NOHA 706	P	C, Cr, Crm	75	75	30	48/48
61 37 x xx	NOHA 706	P	C, Cr, Crm	75	75	35	48/48
61 33 x xx	NOHA 706	P	C, Cr, Crm	75	75	40	48/48
61 34 x xx	NOHA 706	P	C, Cr, Crm	75	75	50	48/48
61 35 x xx	NOHA 706	P	C, Cr, Crm	75	75	60	48/48

NOHA LED K 269



Artik. číslo	Názov	Materiál	Povrch. úprava	□	!	□	H
89 00 1 37	SK 135-NOHA LED K269	P	Crm	100	100	48	48

NOHA K 269



Artik. číslo	Názov	Materiál	Povrch. úprava	□	!	□	H
89 00 x 37	SK 155-NOHA K269	P	Crm	100	100	48	48

NOHA ALFA NOHA GAMA



Artik. číslo	Názov	Materiál	Povrch. úprava	∅	□	!	□
10 83 8 4x	NOHA ALFA	S	C	24	-	-	420
10 84 8 xx	NOHA GAMA	S	C	16	-	-	420

PODNOŽ



Artik. číslo	Názov	Materiál	Povrch. úprava	□	!	□
*	PODNOŽ	S	C	*	*	*

NOHA STOLOVÁ ALU QUADRA



Artik. číslo	Názov	Materiál	Povrch. úprava	□	!	□
16 78 8 00	NOHA STOLOVÁ ALU QUADRA	Al, P	Crm	60	60	710
16 78 8 01	NOHA STOLOVÁ ALU QUADRA	Al, P	Crm	60	60	820

NOHA STOLOVÁ



Artik. číslo	Názov	Materiál	Povrch. úprava	∅	□	□
16 25 x xx	NOHA STOLOVÁ	S, P	Cr, Crm, Nim, biela, čierna	60	-	710
16 26 x xx	NOHA STOLOVÁ	S, P	Cr, Crm, Nim, biela, čierna	60	-	820

STOLOVÁ NOHA SIMPLE



Artik. číslo	Název	Materiál	Povrch. úprava	Hĺbka
DKL9006	STOLOVÁ NOHA SIMPLE	S	Crn, čierna	710-800

STOLOVÁ NOHA PURE & SPILE



Artik. číslo	Název	Materiál	Povrch. úprava	Hĺbka
RL9006	STOLOVÁ NOHA PURE & SPILE VALCOVÁ NOHA	S	Crn, čierna	710
SL9006	STOLOVÁ NOHA PURE & SPILE ŠTVORCOVÁ NOHA	S	Crn, čierna	710

SAMONOSNÝ STOLOVÝ RÁM CUBIC



Artik. číslo	Název	Materiál	Povrch. úprava	Hĺbka	Hĺbka
FCD096	SAMOSTATNÝ STOLOVÝ RÁM CUBIC	S	Crn	900	900
FCD126	SAMOSTATNÝ STOLOVÝ RÁM CUBIC	S	Crn	1200	900
FCD146	SAMOSTATNÝ STOLOVÝ RÁM CUBIC	S	Crn	1400	900
FCD166	SAMOSTATNÝ STOLOVÝ RÁM CUBIC	S	Crn	1600	900
FCD186	SAMOSTATNÝ STOLOVÝ RÁM CUBIC	S	Crn	1800	900
FCD206	SAMOSTATNÝ STOLOVÝ RÁM CUBIC	S	Crn	2000	900
FCD226	SAMOSTATNÝ STOLOVÝ RÁM CUBIC	S	Crn	2200	900
FCD246	SAMOSTATNÝ STOLOVÝ RÁM CUBIC	S	Crn	2400	900

SAMONOSNÝ STOLOVÝ RÁM CUBIC SLIM SAMONOSNÝ STOLOVÝ RÁM CUBIC SLIM MOVE



Artik. číslo	Název	Materiál	Povrch. úprava	Hĺbka	Hĺbka	Hĺbka
FCS08086	SAMOST. STOL. RÁM CUBIC SLIM	S	Crn	800	800	657-807
FCS12086	SAMOST. STOL. RÁM CUBIC SLIM	S	Crn	1200	800	657-807
FCS14086	SAMOST. STOL. RÁM CUBIC SLIM	S	Crn	1400	800	657-807
FCS16086	SAMOST. STOL. RÁM CUBIC SLIM	S	Crn	1600	800	657-807
FCS18086	SAMOST. STOL. RÁM CUBIC SLIM	S	Crn	1800	800	657-807
FCS20086	SAMOST. STOL. RÁM CUBIC SLIM	S	Crn	2000	800	657-807
FCS22086	SAMOST. STOL. RÁM CUBIC SLIM	S	Crn	2200	800	657-807
FCS24086	SAMOST. STOL. RÁM CUBIC SLIM	S	Crn	2400	800	657-807
FCSM14086	SAMOST. STOL. RÁM CUBIC SLIM	S	Crn	1400	800	657-807
FCSM16086	SAMOST. STOL. RÁM CUBIC SLIM	S	Crn	1600	800	657-807
FCSM18086	SAMOST. STOL. RÁM CUBIC SLIM	S	Crn	1800	800	657-807
FCSM20086	SAMOST. STOL. RÁM CUBIC SLIM	S	Crn	2000	800	657-807
FCSM22086	SAMOST. STOL. RÁM CUBIC SLIM	S	Crn	2200	800	657-807
FCSM24086	SAMOST. STOL. RÁM CUBIC SLIM	S	Crn	2400	800	657-807
FCSM08086	SAM. STO. RÁM CUBIC SLIM MOVE	S	Crn	800	-	800
FCSM12086	SAM. STO. RÁM CUBIC SLIM MOVE	S	Crn	1200	-	800

SAMONOSNÝ STOLOVÝ RÁM FTMU



Artik. číslo	Názov	Materiál	Povrch. úprava	Šírka	Hĺbka
FTMU06066	SAMONOSNÝ STOLOVÝ RÁM FTMU	S	Crn, čierna	600	600
FTMU08066	SAMONOSNÝ STOLOVÝ RÁM FTMU	S	Crn, čierna	800	600
FTMU10066	SAMONOSNÝ STOLOVÝ RÁM FTMU	S	Crn, čierna	1000	600
FTMU12066	SAMONOSNÝ STOLOVÝ RÁM FTMU	S	Crn, čierna	1200	600
FTMU14066	SAMONOSNÝ STOLOVÝ RÁM FTMU	S	Crn, čierna	1400	600
FTMU16066	SAMONOSNÝ STOLOVÝ RÁM FTMU	S	Crn, čierna	1600	600
FTMU18066	SAMONOSNÝ STOLOVÝ RÁM FTMU	S	Crn, čierna	1800	600
FTMU20066	SAMONOSNÝ STOLOVÝ RÁM FTMU	S	Crn, čierna	2000	600
FTMU08086	SAMONOSNÝ STOLOVÝ RÁM FTMU	S	Crn, čierna	800	800
FTMU10086	SAMONOSNÝ STOLOVÝ RÁM FTMU	S	Crn, čierna	1000	800
FTMU12086	SAMONOSNÝ STOLOVÝ RÁM FTMU	S	Crn, čierna	1200	800
FTMU14086	SAMONOSNÝ STOLOVÝ RÁM FTMU	S	Crn, čierna	1400	800
FTMU16086	SAMONOSNÝ STOLOVÝ RÁM FTMU	S	Crn, čierna	1600	800
FTMU18086	SAMONOSNÝ STOLOVÝ RÁM FTMU	S	Crn, čierna	1800	800
FTMU20086	SAMONOSNÝ STOLOVÝ RÁM FTMU	S	Crn, čierna	2000	800

SAMONOSNÝ STOLOVÝ RÁM FTU

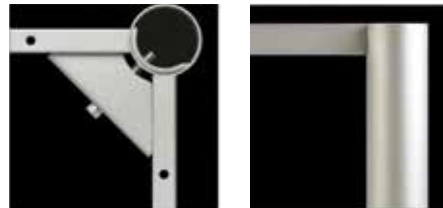

Artik. číslo	Názov	Materiál	Povrch. úprava	Šírka	Hĺbka
FTU06066	SAMOSTATNÝ STOLOVÝ RÁM FTU	S	Crn, čierna	600	600
FTU08066	SAMOSTATNÝ STOLOVÝ RÁM FTU	S	Crn, čierna	800	600
FTU10066	SAMOSTATNÝ STOLOVÝ RÁM FTU	S	Crn, čierna	1000	600
FTU12066	SAMOSTATNÝ STOLOVÝ RÁM FTU	S	Crn, čierna	1200	600
FTU14066	SAMOSTATNÝ STOLOVÝ RÁM FTU	S	Crn, čierna	1400	600
FTU16066	SAMOSTATNÝ STOLOVÝ RÁM FTU	S	Crn, čierna	1600	600
FTU18066	SAMOSTATNÝ STOLOVÝ RÁM FTU	S	Crn, čierna	1800	600
FTU20066	SAMOSTATNÝ STOLOVÝ RÁM FTU	S	Crn, čierna	2000	600
FTU08086	SAMOSTATNÝ STOLOVÝ RÁM FTU	S	Crn, čierna	800	800
FTU10086	SAMOSTATNÝ STOLOVÝ RÁM FTU	S	Crn, čierna	1000	800
FTU12086	SAMOSTATNÝ STOLOVÝ RÁM FTU	S	Crn, čierna	1200	800
FTU14086	SAMOSTATNÝ STOLOVÝ RÁM FTU	S	Crn, čierna	1400	800
FTU16086	SAMOSTATNÝ STOLOVÝ RÁM FTU	S	Crn, čierna	1600	800
FTU18086	SAMOSTATNÝ STOLOVÝ RÁM FTU	S	Crn, čierna	1800	800
FTU20086	SAMOSTATNÝ STOLOVÝ RÁM FTU	S	Crn, čierna	2000	800

SAMONOSNÁ PODNOŽ BASIC SAMONOSNÁ PODNOŽ BASIC PLUS



Artik. číslo	Názov	Materiál	Povrch. úprava	Šírka	Hĺbka
R69006	SAMONOSNÁ PODNOŽ BASIC	S	Crn, čierna	-	600
R89006	SAMONOSNÁ PODNOŽ BASIC	S	Crn, čierna	-	800
F1R69006	SAMONOSNÁ PODNOŽ BASIC PLUS	S	Crn, čierna	1000-1420	600
F1R89006	SAMONOSNÁ PODNOŽ BASIC PLUS	S	Crn, čierna	1000-1420	800
F2R69006	SAMONOSNÁ PODNOŽ BASIC PLUS	S	Crn, čierna	1450-2300	600
F2R89006	SAMONOSNÁ PODNOŽ BASIC PLUS	S	Crn, čierna	1450-2300	800

SKLADACIA PODNOŽ EASY FBX





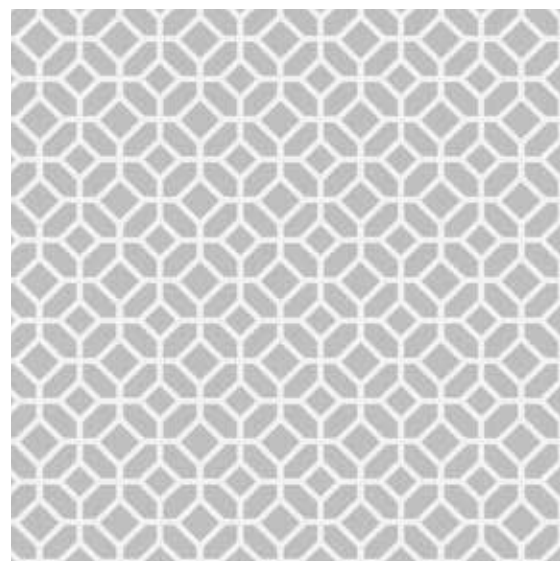
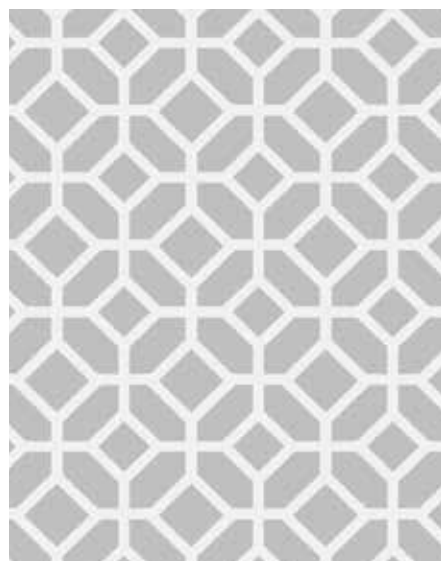
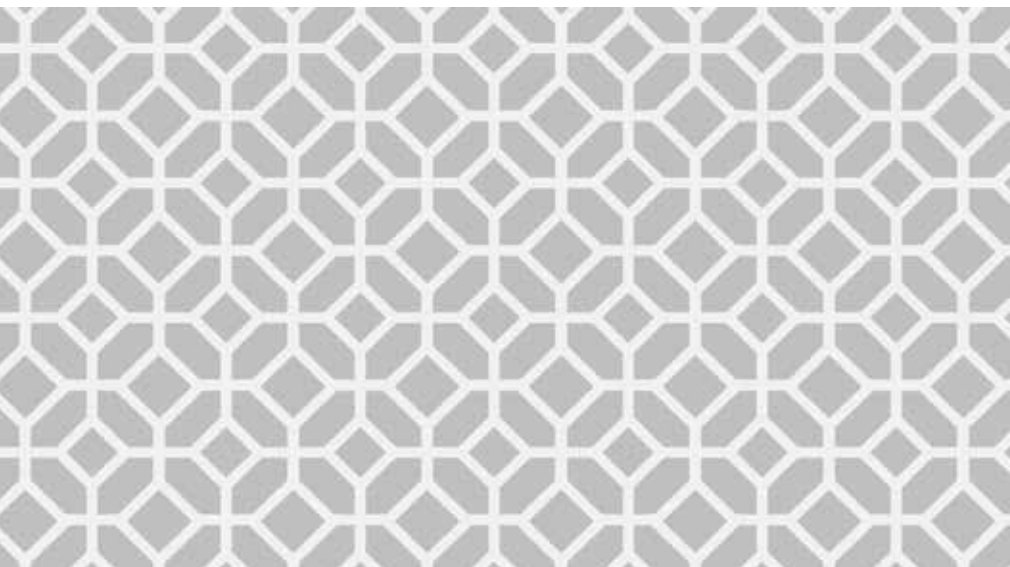

Artik. číslo	Názov	Materiál	Povrch. úprava	Šírka	Hĺbka
FBF0606	SKLADACIA PODNOŽ EASY FBX	S	Crn	720	550/610



STOLOVÉ KOVANIE
TABLE FITTINGS

POSUVNÉ KOVANIA PRE STOLY

	ALU 77	BASIC ADVANCED	CLASSIC	SKLÁPACIE KOVANIE
				
Strana	86	86	86	87
Princíp fungovania	Delená doska - pevné stolové nohy	Delená doska - pevné stolové nohy	Delená doska - posuvné stolové nohy	-
Popis	Stolový výsuv s pevnou podnožou	Stolový výsuv pre stoly s lubmi	Stolový výsuv pre kulisové stoly	sklápacia mechanika
Dĺžka stola bez vlozenej dosky max. mm	1400, 1800, 2400	800, 1400, 1800	1400, 1800	-
Dĺžka stola s vloženou doskou max. mm	2900, 3600, 5400	1200, 1900, 2800	2400, 2800	-
Vstavaná dĺžka	980, 1200, 1800	600, 850, 1350	1070, 1400	-
Počet vložených dosiek max	3 x 500 mm, 3 x 600 mm, 6 x 500 mm	1 x 400 mm, 1 x 500 mm, 2 x 500 mm	2 x 500 mm	1 x 500 mm
Materiál	hliník eloxovaný	oceľ pozinkovaná	oceľ pozinkovaná	-
Funkcia	lanková brzda/ synchronné ovládanie	lanková brzda, synchronné ovládanie, je možné kombinovať so sklopným kovaním	bez brzdy	pre BASIC ADVANCED
Nosnosť	115 kg	pri vstavanej dĺžke 600 mm = 60 kg 850 a 1350 mm = 90 kg	90 kg	-

	TOPSLIDE	FRONTSIDE BASIC ALU 55	FRONTSIDE ALU 77	SKLÁPACIA MECHANIKA
				
Strana	87	86	87	87
Princíp fungovania	Nedelená doska - pevné stolové nohy	Nedelená doska - pevné stolové nohy	Nedelená doska - posuvné stolové nohy	-
Popis	Stolový výsuv pre stoly s lubmi	Stolový výsuv preberá funkciu lubov	Stolový výsuv preberá funkciu lubov	sklápacia mechanika s brzdou pre stolové výsuvy bez lubov
Dĺžka stola bez vlozenej dosky max. mm	800, 1400, 2000	min. 1000	1300, 1800, 2400	-
Dĺžka stola s vloženou doskou max. mm	1150, 2000, 3000	min. 1500	1800, 2800, 3400	-
Vstavaná dĺžka	600, 1000, 1500	830	940, 1315, 1815	-
Počet vložených dosiek max	1 x 350 mm, 1 x 600 mm, 1 x 1000 mm	1 x 500 mm	2 x 500 mm	1 x 600 mm, 2 x 500 mm, 2 x 600 mm
Materiál	oceľ pozinkovaná	hliník eloxovaný	hliník eloxovaný	-
Funkcia	lanková brzda	voliteľne je možné kombinovať so sklápacou mechanikou s brzdou	voliteľne je možné kombinovať so sklápacou mechanikou s brzdou	pre FRONTSIDE ALU 55, FRONTSIDE ALU 77
Nosnosť	90 kg	90 kg	-	-

ALU 77



Sada obsahuje:
stolový výsuv - 1 sada
kolík a púzdro podľa dĺžky stola - 16, resp. 28 kusov

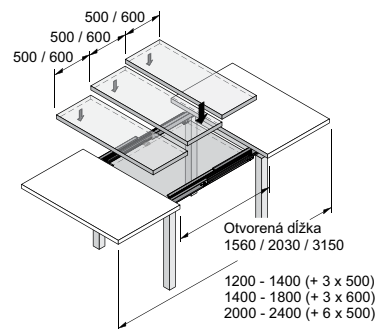
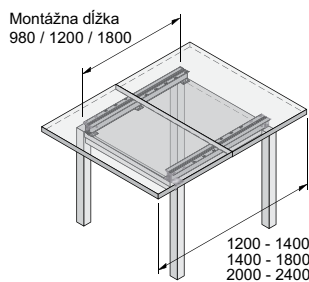

Artik. číslo	Vstavaná dĺžka (v mm)	Pre dĺžku stola (mm)	Počet vložených dosiek	Šírka vložených dosiek (mm)
809 133 044	980	1200 - 1400	3	500
809 133 045	1200	1400 - 1800	3	600
809 133 046	1800	2000 - 2400	6	500

BASIC ADVANCED



Sada obsahuje:
stolový výsuv - 1 sada
kolík a púzdro podľa dĺžky stola - 8, resp. 12 kusov

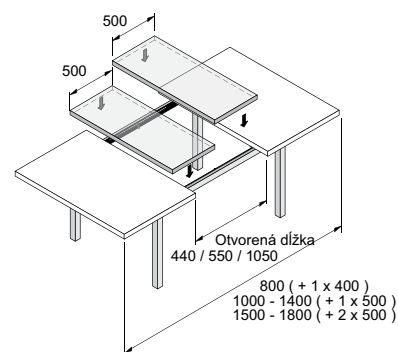
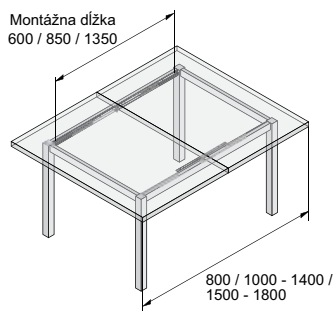

Artik. číslo	Vstavaná dĺžka (v mm)	Pre dĺžku stola (mm)	Počet vložených dosiek	Šírka vložených dosiek (mm)
809 133 036	600	800	1	400
809 079 740	850	1000 - 1400	1	500
809 079 741	1350	1500 - 1800	2	500

CLASSIC



Sada obsahuje:
stolový výsuv - 1 sada
kolík - 12 kusov
upínací zámok - 6 kusov

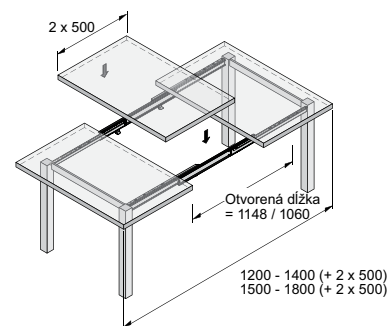
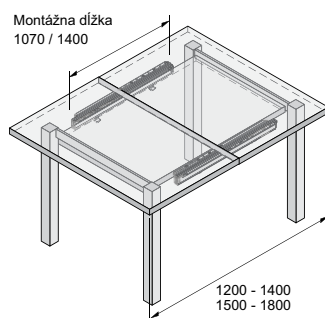

Artik. číslo	Vstavaná dĺžka (v mm)	Pre dĺžku stola (mm)	Počet vložených dosiek	Šírka vložených dosiek (mm)
809 133 042	1070	1200 - 1400	2	500
809 133 043	1400	1500 - 1800	2	500

ALU 55 FRONTSLIDE BASIC



Sada obsahuje:
stolový výsuv - 1 sada
kolík - 12 kusov
upínací zámok - 6 kusov

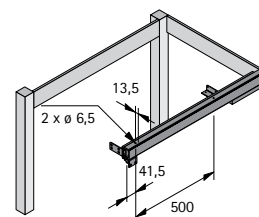
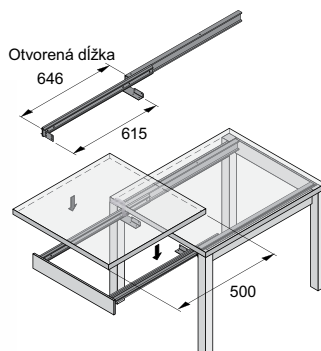

Artik. číslo	Vstavaná dĺžka (v mm)	Pre dĺžku stola (mm)	Počet vložených dosiek	Šírka vložených dosiek (mm)
809 131 984	830	1000	1	500

TOPSLIDE

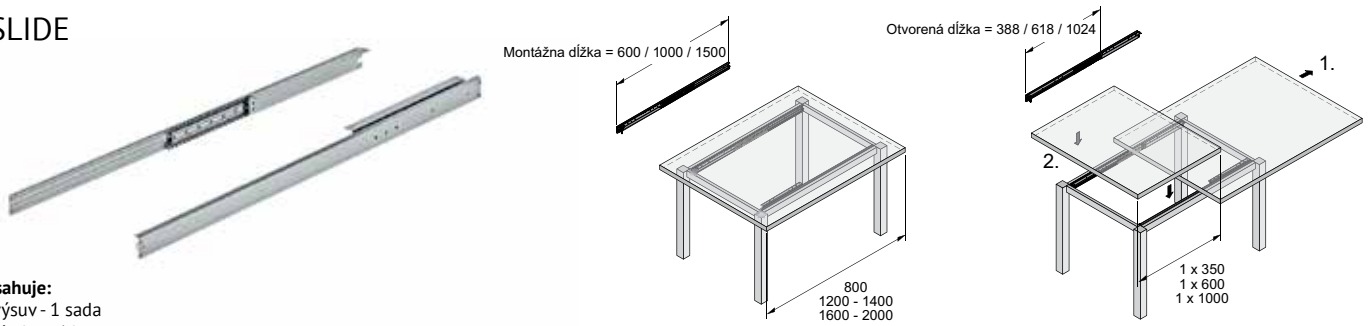

Sada obsahuje:
stolový výsuv - 1 sada
kolík a púzdro - 4 kusy

Artik. číslo	Vstavaná dĺžka (v mm)	Pre dĺžku stola (mm)	Počet vložených dosiek	Šírka vložených dosiek (mm)
809 133 039	600	800	1	350
809 133 040	1000	1200 - 1400	1	600
809 133 041	1500	1600 - 2000	1	1000

FRONTSIDE ALU 77

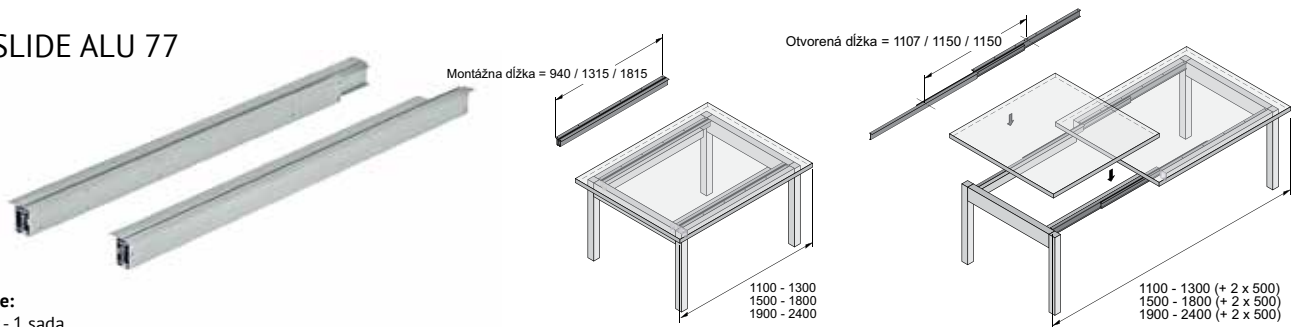

Sada obsahuje:
stolový výsuv - 1 sada
kolík a púzdro - 12 kusov

Artik. číslo	Vstavaná dĺžka (v mm)	Pre dĺžku stola (mm)	Počet vložených dosiek	Šírka vložených dosiek (mm)
809 133 047	940	1100 - 1300	2	500
809 133 048	1315	1500 - 1800	2	500
809 133 049	1815	1900 - 2400	2	500

SKLÁPACIA MECHANIKA S BRZDOU

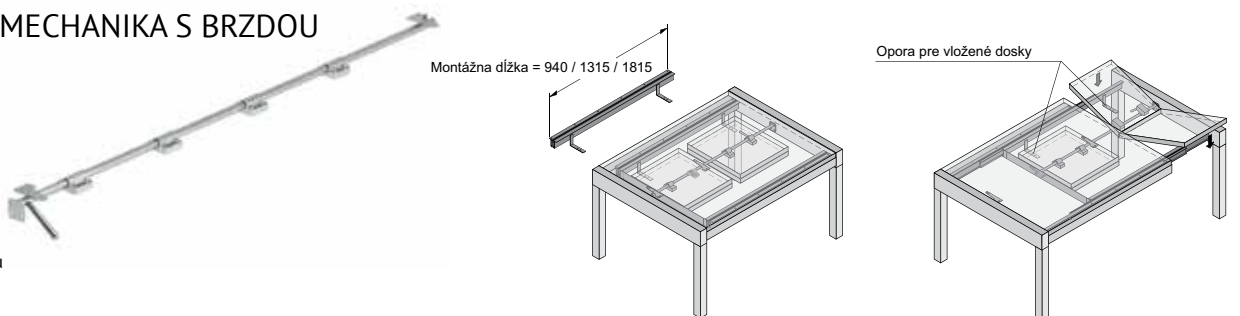

Sada obsahuje:
tyč s brzdovou pákou
plastové objímky
uholník

Artik. číslo	Pre vložené dosky	Pre stolové výsuvy
809 137 961	max. 600 mm	Frontslide Alu 55, Frontslide Alu 77
809 137 962	max. 2 x 400 mm alebo 1 x 800 mm	Frontslide Alu 77
809 137 963	max. 2 x 500 mm alebo 1 x 1000 mm	Frontslide Alu 77

SKLÁPACIE KOVANIE

- použitie so stolovým výsuvom a uzatvorenou podstavou alebo centrálnou nohou

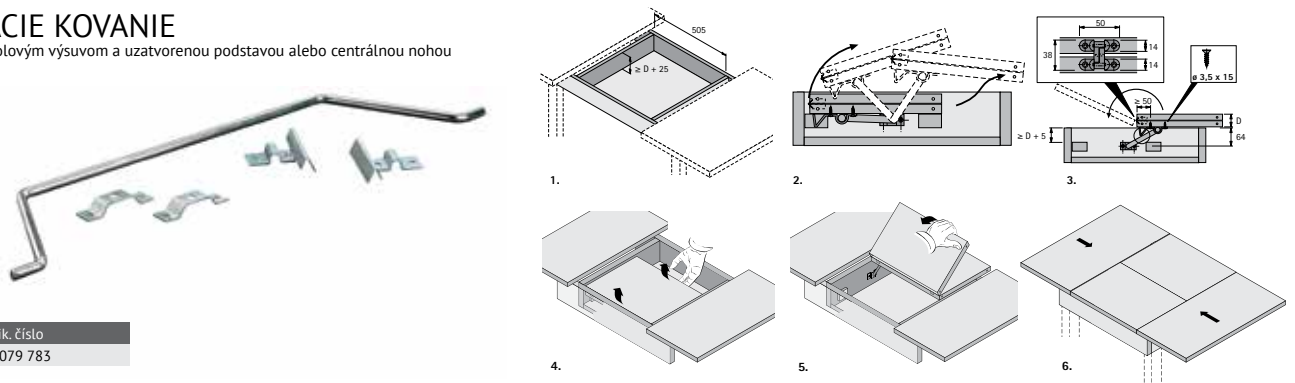

Artik. číslo
809 079 783

SKLÁPACIE KOVANIE

- použitie so stolovým výsuvom a uzatvorenou podstavou alebo centrálnou nohou

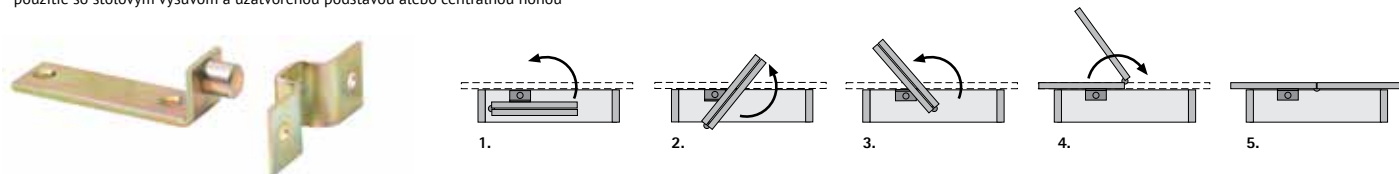

Artik. číslo
809 079 707

VÝSTUHA PRE DOSKY Z MASÍVNEHO DREVA

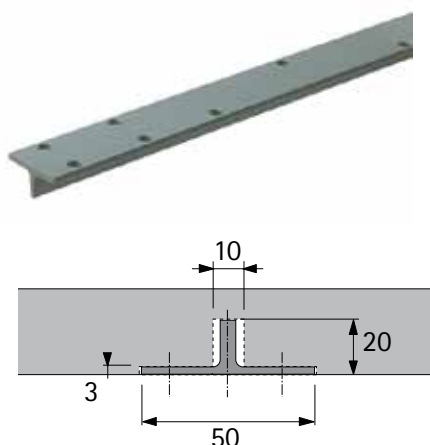

Artik. číslo	Názov	Materiál	Povrch. úprava	l	h	B	Balenie
809 137 970	Výstuha pre dosky	S	Zn	400	50	20	2 ks
809 137 971	Výstuha pre dosky	S	Zn	500	50	20	2 ks
809 141 821	Výstuha pre dosky	S	Zn	700	50	20	2 ks
809 137 972	Výstuha pre dosky	S	Zn	800	50	20	2 ks
809 137 973	Výstuha pre dosky	S	Zn	900	50	20	2 ks

STOLOVÝ KLZÁK S FILCOM

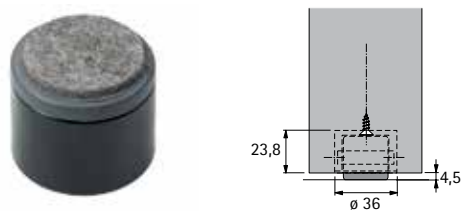

Artik. číslo	Názov	Materiál	Povrch. úprava	Ø	h	Balenie
809 133 053	Stolový klzák s filcom	P	čierna	36	23,8	2 kusy

STOLOVÝ KLZÁK PRE TVRDÉ PODLAHY

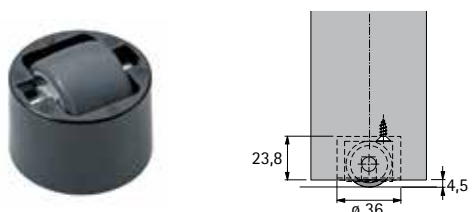

Artik. číslo	Názov	Materiál	Povrch. úprava	Ø	h	Balenie
809 133 055	Stolový klzák s kolieskom	P	čierna	36	23,8	2 kusy

ZAMYKACÍ HÁČIK

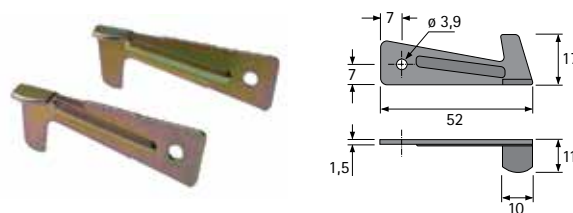

Artik. číslo	Názov	Materiál	Povrch. úprava	l	h	Balenie
809 133 058	Zamykací háčik	S	Zn	52	17	2 kusy

KOLÍKY A PŮZDRA

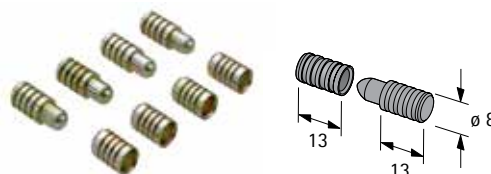

Artik. číslo	Názov	Materiál	Povrch. úprava	Ø	l	Balenie
809 133 060	Kolíky a púzdra	Zn	Zn	8	13	4 sady

STOLOVÝ KLZÁK

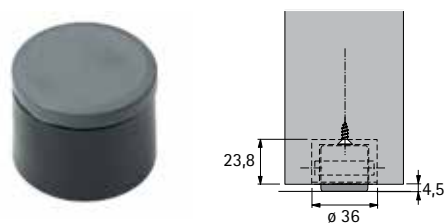

Artik. číslo	Názov	Materiál	Povrch. úprava	Ø	h	Balenie
809 133 052	Stolový klzák	P	čierna	36	23,8	2 kusy

STOLOVÝ KLZÁK PRE MÄKKÉ PODLAHY

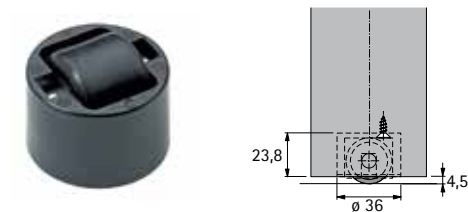

Artik. číslo	Názov	Materiál	Povrch. úprava	Ø	h	Balenie
809 133 054	Stolový klzák s kolieskom	P	čierna	36	23,8	2 kusy

UHOLNÍK PRE VLOŽENÚ DOSKU

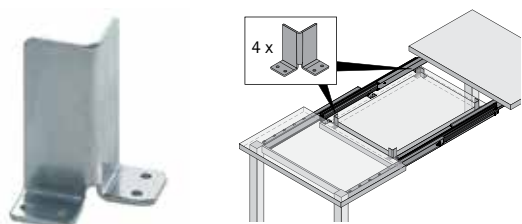

Artik. číslo	Názov	Materiál	Povrch. úprava	Balenie
809 133 062	Uholník pre vloženú dosku	S	Zn	4 kusy

UHOLNÍK SPOJOVACÍ

- traverzový uholník pre pripojenie rámu FRONTSLIDE ALU 77

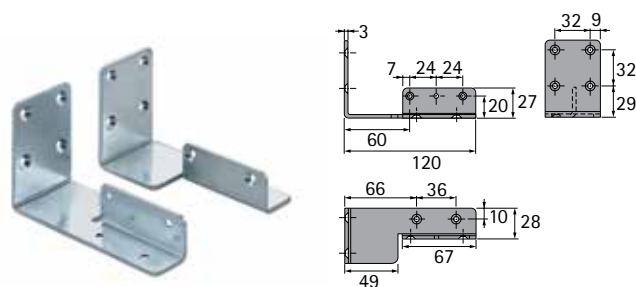

Artik. číslo	Názov	Materiál	Povrch. úprava	Balenie
809 133 064	Uholník pre vloženú dosku	S	Zn	1 sada

ROHOVÝ PLECH -SPOJ STOLA



Artik. číslo	Názov	Materiál	Povrch. úprava	50	78	32
16 03 5 00	ROHOVÝ PLECH-SPOJ STOLA 50	S	Zn	50	50	32
16 03 5 01	ROHOVÝ PLECH-SPOJ STOLA 78	S	Zn	78	78	32

ROHOVÝ SPOJ STOLA SK 342

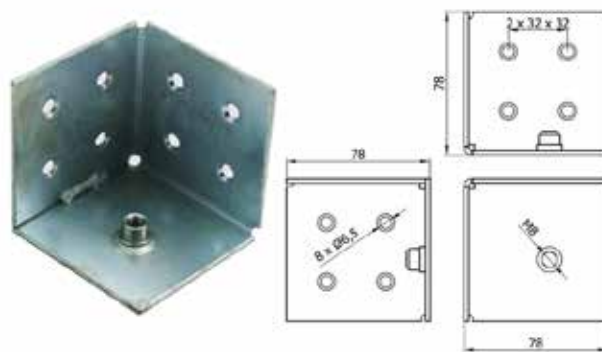

Artik. číslo	Názov	Materiál	Povrch. úprava	78	78	78
16 00 0 00	Rohový spoj stola SK 342	S	Zn	78	78	78

ROHOVÝ SPOJ STOLA SK 343

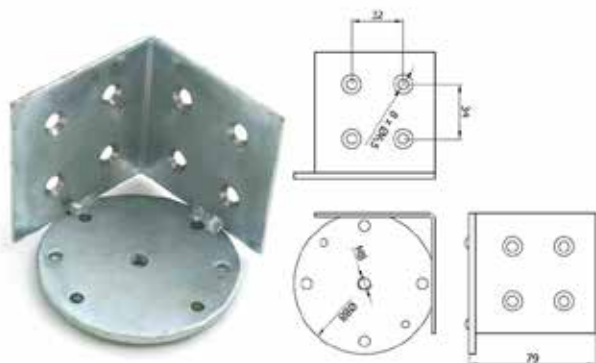

Artik. číslo	Názov	Materiál	Povrch. úprava	78	78	78
16 00 1 00	Rohový spoj stola SK 343	S	Zn	78	78	78

FURUSET



Artik. číslo	Názov	Materiál	Povrch. úprava	2	155	25	70
16 03 1 80	FURUSET 70	S	Zn	2	155	25	70
16 03 3 50	FURUSET 50	S	Zn	1,8	112	55	50

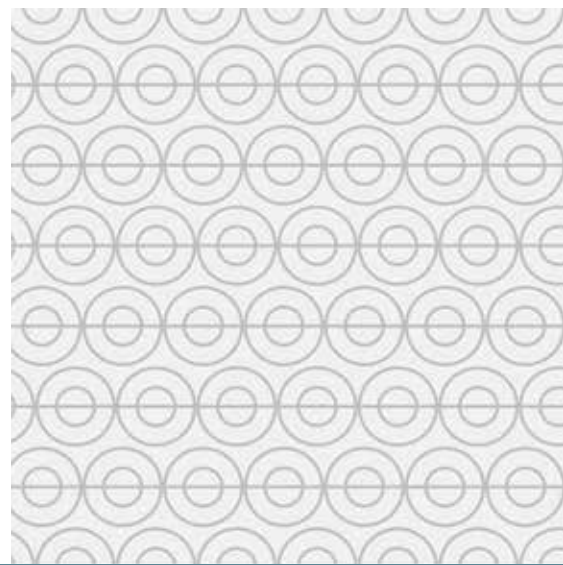
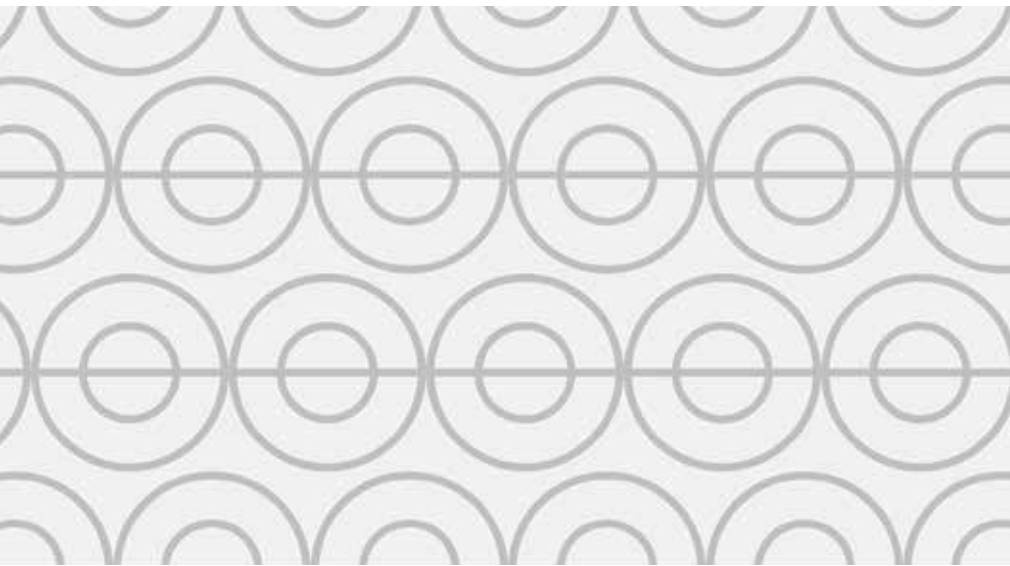

KOLIESKA
WHEELS

KKNR Ø 24



Artik. číslo	Názov	Materiál	Povrch. úprava	Ø	l	⌀
07 73 2 90	KKNR Ø 24 PEVNÉ KOLIESKO	S, P	Ni, čierna	24	26	42

KKNS Ø 24



Artik. číslo	Názov	Materiál	Povrch. úprava	Ø	l	⌀
07 71 2 90	KKNS Ø 24 PEVNÉ KOLIESKO	S, P	Ni, čierna	24	32	42

PEVNÉ KOLIESKO Ø 32



Artik. číslo	Názov	Materiál	Povrch. úprava	Ø	l	⌀
27 00 9 1x	PEVNÉ KOLIESKO Ø 32	S, P	Zn, čierna, biela	32	51	40

PEVNÉ KOLIESKO S GUMOU Ø 30



Artik. číslo	Názov	Materiál	Povrch. úprava	Ø	l	⌀
27 00 9 30	PEVNÉ KOLIESKO s gumou Ø 30	S, P, R	Zn, šedá	30	32	38

PEVNÉ KOLIESKO S GUMOU Ø 45



Artik. číslo	Názov	Materiál	Povrch. úprava	Ø	l	⌀
27 00 9 23	PEVNÉ KOLIESKO s gumou Ø 45	S, P, R	Zn, šedá	45	50	55

PEVNÉ KOLIESKO S GUMOU Ø 50

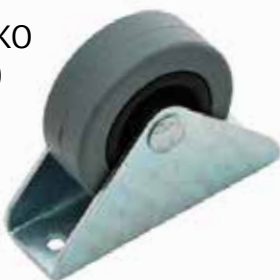

Artik. číslo	Názov	Materiál	Povrch. úprava	Ø	l	⌀
27 00 9 20	PEVNÉ KOLIESKO s gumou Ø 50	S, P, R	Zn, šedá	50	60	40

OTOČNÉ KOLIESKO Ø 24



Artik. číslo	Názov	Materiál	Povrch. úprava	Ø	l	⌀
27 00 9 01	OTOČNÉ KOLIESKO Ø 24	S, P	Zn, čierna	24	32	36

KKOS Ø 24



Artik. číslo	Názov	Materiál	Povrch. úprava	Ø	l	⌀
07 70 2 90	KKOS Ø 24 OTOČNÉ KOLIESKO	S, P	Ni, čierna	24	34	42

KKOH Ø 24



Artik. číslo	Názov	Materiál	Povrch. úprava	Ø	l	⌀
07 72 2 90	KKOH Ø 24 OTOČNÉ KOLIESKO	S, P	Ni, čierna	24	50/34	

OTOČNÉ KOLIESKO S GUMOU Ø 30



Artik. číslo	Názov	Materiál	Povrch. úprava	Ø	l	⌀
27 00 9 31	OTOČNÉ KOLIESKO s gumou Ø 30	S, P, R	Zn, šedá	30	42	32

PEVNÉ KOLIESKO S GUMOU Ø 45 BOČNÉ



Artik. číslo	Názov	Materiál	Povrch. úprava	Ø	l	⌀
27 00 9 24	Pevné s gumou Ø 45 bočné	S, P, R	Zn, šedá	45	50	55/32

OTOČNÉ KOLIESKO S GUMOU Ø 50

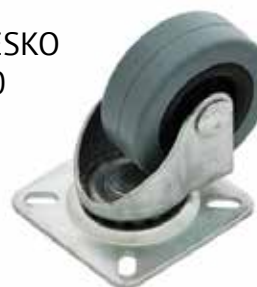

Artik. číslo	Názov	Materiál	Povrch. úprava	Ø	l	⌀
27 00 9 21	OTOČNÉ KOLIESKO s gumou Ø 50	S, P, R	Zn, šedá	50	60	40/40

ONK 40
ONK 40 P



Artik. číslo	Názov	Materiál	Povrch. úprava	∅	T	∅	l	∅	∅
07 24 2 0x	ONK 40	Zn, S	Ni	40	-	8	70/45	-	-
07 25 2 0x	ONK 40 P	Zn, S	Ni	40	26/26	-	56	18/18	-

ONK 50
ONK 50 P



Artik. číslo	Názov	Materiál	Povrch. úprava	∅	T	∅	l	∅	∅
07 44 2 0x	ONK 50	Zn, S	Ni	50	-	9	93/57	-	-
07 45 2 0x	ONK 50 P	Zn, S	Ni	50	40/40	-	71	25/25	-

NDS- 2
NDP- 2



Artik. číslo	Názov	Materiál	Povrch. úprava	∅	T	∅	l	∅	∅
07 04 2 90	NDS- 2 OTOČNÉ KOLIESKO	Zn, S, P	Ni, čierna	50	-	9	85/52	-	-
07 05 2 90	NDP- 2 OTOČNÉ KOLIESKO	Zn, S, P	Ni, čierna	50	40/40	-	65	25/25	-

A 40 A8



Artik. číslo	Názov	Materiál	Povrch. úprava	∅	∅	l
27 05 9 00	A 40 A8- OTOČNÉ KOLIESKO	P, S	čierna	40	8x28	50

A 40 C8



Artik. číslo	Názov	Materiál	Povrch. úprava	∅	∅	l
27 05 9 02	A 40 C8- OTOČNÉ KOLIESKO	P, S	čierna	40	8x15	50

A 40 G A8



Artik. číslo	Názov	Materiál	Povrch. úprava	∅	∅	l
27 05 9 16	A 40 G A8- OTOČNÉ KOLIESKO	P, S, R	čierna, šedá	40	8x28	50

B 40 A8



Artik. číslo	Názov	Materiál	Povrch. úprava	∅	∅	l
27 05 9 51	B 40 A8- OTOČNÉ KOLIESKO	P, S	čierna	40	8x28	50

B 50 M10



Artik. číslo	Názov	Materiál	Povrch. úprava	∅	∅	l
27 07 9 25	B 50 M10- OTOČNÉ KOLIESKO	P, S	čierna	50	M10x20	56

A 50 M10



Artik. číslo	Názov	Materiál	Povrch. úprava	∅	∅	l
27 06 9 27	A 50 M10- OTOČNÉ KOLIESKO	P, S	čierna	50	M10x20	56

C 50 G M10



Artik. číslo	Názov	Materiál	Povrch. úprava	∅	∅	l
27 09 9 25	A 50 G M10- OTOČNÉ KOLIESKO	P, S, R	čierna, šedá	50	M10x20	56

A 40 M8



Artik. číslo	Názov	Materiál	Povrch. úprava	∅	h	h ₁
27 05 9 10	A 40 M8- OTOČNÉ KOLIESKO	P, S	čierna	40	M8x16	50

A 40 D42



Artik. číslo	Názov	Materiál	Povrch. úprava	∅	h	h ₁	h ₂
27 05 9 07	A 40 D42- OTOČNÉ KOLIESKO	P, S	čierna	40	42x42	50	32

A 40 D45



Artik. číslo	Názov	Materiál	Povrch. úprava	∅	h	h ₁	h ₂
27 05 9 05	A 40 D45- OTOČNÉ KOLIESKO	P, S	čierna	40	45x45	50	32

A 40 G D45



Artik. číslo	Názov	Materiál	Povrch. úprava	∅	h	h ₁	h ₂
27 05 9 15	A 40 G D45- OTOČNÉ KOLIESKO	P, S, R	čierna, šedá	40	45x45	50	32

A 50 A8



Artik. číslo	Názov	Materiál	Povrch. úprava	∅	h	h ₁
27 06 9 00	A 50 A8- OTOČNÉ KOLIESKO	P, S	čierna	50	8x28	56

B 50 A8



Artik. číslo	Názov	Materiál	Povrch. úprava	∅	h	h ₁
27 07 9 00	B 50 A8- OTOČNÉ KOLIESKO	P, S	čierna	50	8x28	56

A 50 A10



Artik. číslo	Názov	Materiál	Povrch. úprava	∅	h	h ₁
27 06 9 07	A 50 A10- OTOČNÉ KOLIESKO	P, S	čierna	50	10x25	56
27 06 9 08	A 50 B10- OTOČNÉ KOLIESKO	P, S	čierna	50	10x31	56

B 50 A10



Artik. číslo	Názov	Materiál	Povrch. úprava	∅	h	h ₁
27 07 9 07	B 50 A10- OTOČNÉ KOLIESKO	P, S	čierna	50	10x25	56

A 50 M8



Artik. číslo	Názov	Materiál	Povrch. úprava	∅	h	h ₁
27 06 9 26	A 50 M8- OTOČNÉ KOLIESKO	P, S	čierna	50	M8x16	56

B 50 M8



Artik. číslo	Názov	Materiál	Povrch. úprava	∅	h	h ₁
27 07 9 26	B 50 M8- OTOČNÉ KOLIESKO	P, S	čierna	50	M8x16	56

A 50 D45



Artik. číslo	Názov	Materiál	Povrch. úprava	∅	T	L	H
27 06 9 05	A 50 D45- OTOČNÉ KOLIESKO	P, S	čierna	50	45x45	56	32

B 50 G M8



Artik. číslo	Názov	Materiál	Povrch. úprava	∅	T	L	H
27 11 9 11	B 50 G M8- OTOČNÉ KOLIESKO	P, S, R	čierna, šedá	50	M8x16	56	

A 50 D42



Artik. číslo	Názov	Materiál	Povrch. úprava	∅	T	L	H
27 06 9 06	A 50 D42- OTOČNÉ KOLIESKO	P, S	čierna	50	42x42	56	32

B 50 D45



Artik. číslo	Názov	Materiál	Povrch. úprava	∅	T	L	H
27 07 9 05	B 50 D45- OTOČNÉ KOLIESKO	P, S	čierna	50	45x45	56	32

A 50 G D45



Artik. číslo	Názov	Materiál	Povrch. úprava	∅	T	L	H
27 09 9 07	A 50 G D45- OTOČNÉ KOLIESKO	P, S, R	čierna, šedá	50	45x45	56	32

A 50 G D42



Artik. číslo	Názov	Materiál	Povrch. úprava	∅	T	L	H
27 09 9 09	A 50 G D42- OTOČNÉ KOLIESKO	P, S, R	čierna, šedá	50	42x42	56	32

D 50 G E11



Artik. číslo	Názov	Materiál	Povrch. úprava	∅	T	L	H
27 11 9 09	D 50 G E11- OTOČNÉ KOLIESKO	P, S, R	čierna, šedá	50	11x20	56	

A 50 P-U



Artik. číslo	Názov	Materiál	Povrch. úprava	∅	T	L	H
27 06 9 12	A 50 P-U- OTOČNÉ KOLIESKO	P, S	čierna	50	20x20	56	25

C 50 A10



Artik. číslo	Názov	Materiál	Povrch. úprava	∅	T	L	H
27 08 9 07	C 50 A10- OTOČNÉ KOLIESKO	P, S	čierna	50	10x25	56	

A 50 G A10



Artik. číslo	Názov	Materiál	Povrch. úprava	∅	T	L	H
27 09 9 07	A 50 G A10- OTOČNÉ KOLIESKO	P, S, R	čierna, šedá	50	10x25	56	

C 50 B10



Artik. číslo	Název	Materiál	Povrch. úprava	Ø	T	L	⊕
27 08 9 08	C 50 B10- OTOČNÉ KOLIESKO	P, S	čierna	50	10x31	56	

C 50 G B10



Artik. číslo	Název	Materiál	Povrch. úprava	Ø	T	L	⊕
27 08 9 06	C 50 G B10- OTOČNÉ KOLIESKO	P, S, R	čierna, šedá	50	10x31	56	

C 50 E11



Artik. číslo	Název	Materiál	Povrch. úprava	Ø	T	L	⊕
27 08 9 09	C 50 E11- OTOČNÉ KOLIESKO	P, S	čierna	50	11x20	56	

C 50 G E11



Artik. číslo	Název	Materiál	Povrch. úprava	Ø	T	L	⊕
27 11 9 10	C 50 G E11- OTOČNÉ KOLIESKO	P, S, R	čierna, šedá	50	11x20	56	

CB 50 A10



Artik. číslo	Název	Materiál	Povrch. úprava	Ø	T	L	⊕
27 12 9 07	CB 50 A10- OTOČNÉ KOLIESKO+brzda	P, S	čierna	50	10x25	56	

B 60 M10- 1002 F



Artik. číslo	Název	Materiál	Povrch. úprava	Ø	T	L	⊕
27 26 9 00	B 60 M10- 1002F OTOČNÉ KOLIESKO	P, S	šedá	60	M10x15	72	

OTOČNÉ KOLIESKO
S BRZDOU
SILIKÓN Ø 50



Artik. číslo	Název	Materiál	Povrch. úprava	Ø	T	L	⊕
27 00 9 70	OTOČNÉ KOL. S BRZDOU 50	PVC, S	Cr	50	50x50	65	38x38

OTOČNÉ KOLIESKO
SILIKÓN Ø 50



Artik. číslo	Název	Materiál	Povrch. úprava	Ø	T	L	⊕
27 00 9 60	OTOČNÉ KOLIESKO 50	PVC, S	Cr	50	50x50	64	38x38

OTOČNÉ KOLIESKO
SILIKÓN Ø 75



Artik. číslo	Název	Materiál	Povrch. úprava	Ø	T	L	⊕
27 00 9 80	OTOČNÉ KOLIESKO 75	PVC, S	Cr	75	50x50	91	38x38
27 00 9 90	OTOČNÉ KOLIESKO 75 s brzdou	PVC, S	Cr	75	50x50	91	38x38

A 80 D42- 1005



Artik. číslo	Název	Materiál	Povrch. úprava	Ø	T	L	⊕
27 27 9 00	A 80 D42- 1005	P, S	Cr	80	60x60	112	45/45

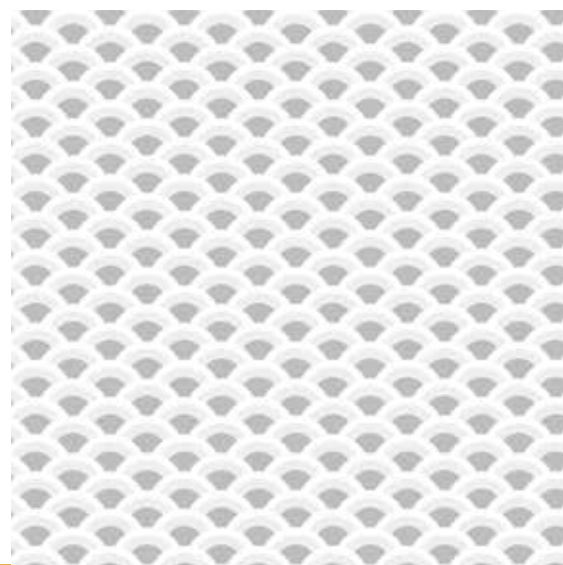
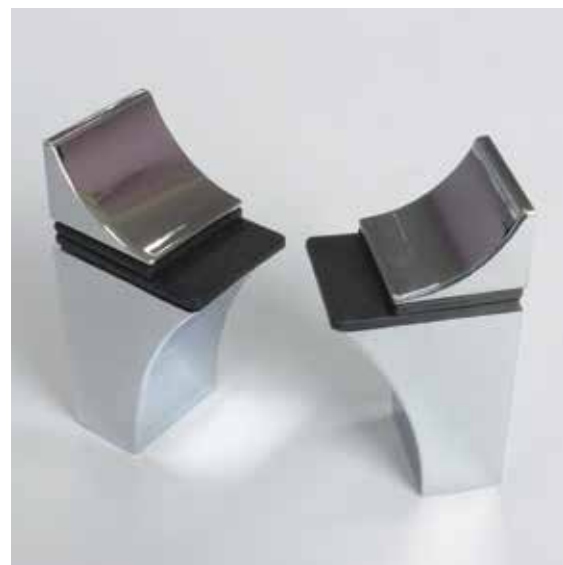

KONŠTRUKČNÉ PRVKY
FITTING ELEMENTS

PODPERA TUCANO



Artik. číslo	Názov	Materiál	Povrch. úprava	□	!	▮
16 01 9 xx	PODPERA TUCANO 40 mm	Zn, P	Cr, biela, Crm, Nim	40	23	43
16 01 9 xx	PODPERA TUCANO 54 mm	Zn, P	Cr, biela, Crm, Nim	50	31	55
16 01 9 xx	PODPERA TUCANO 75 mm	Zn, P	Cr, biela, Crm, Nim	75	31	66
16 01 9 xx	PODPERA TUCANO 105 mm	Zn, P	Cr, biela, Crm, Nim	105	40	84

PODPERA



Artik. číslo	Názov	Materiál	Povrch. úprava	□	!	▮
16 02 x 02	PODPERA 30x30	Zn, P	Cr, Crm, Nim	30	30	46
16 02 x 03	PODPERA 40x40	Zn, P	Cr, Crm, Nim	40	40	53

PODPERA OVÁL



Artik. číslo	Názov	Materiál	Povrch. úprava	□	!	▮
16 02 x 01	PODPERA OVÁL	Zn, P	Cr, Crm, Nim	30	25	46

PODPERA 30 EMU



Artik. číslo	Názov	Materiál	Povrch. úprava	□	!	▮
16 02 x 12	PODPERA 30 EMU	S, P	Cr, Crm, li	59	24	35

PODPERA SKLENEJ POLICE



Artik. číslo	Názov	Materiál	Povrch. úprava	∅	▮
16 01 0 04	PODPERA SKLENEJ POLICE 41	S	Cr	12	173
16 01 0 05	PODPERA SKLENEJ POLICE 38	S	Cr	12	173

PODPERA 906



Artik. číslo	Názov	Materiál	Povrch. úprava	□	!	▮
16 01 8 xx	PODPERA 906	P, S	C	85	30	53

PODPERA HRANOL



Artik. číslo	Názov	Materiál	Povrch. úprava	□	!	▮
16 02 x 04	PODPERA HRANOL	Zn, P	Cr, Crm, Nim	67	24	86

PODPERA 58x50



Artik. číslo	Názov	Materiál	Povrch. úprava	□	!	▮
16 02 x 05	PODPERA 58x50	S, P	Cr, Crm, Nim	58	50	35

KONZOLA SKRYTÁ



Artik. číslo	Názov	Materiál	Povrch. úprava	∅	▮
16 09 9 00	KONZOLA SKRYTÁ	S, P	hnedá	12	120

KONZOLA L



Artik. číslo	Názov	Materiál	Povrch. úprava	∅	—	!	—	!	—	!
09 19 8 04	KONZOLA L	S	C	20	198	30	100	94/60		

KONZOLA SKRYTÁ NASTAVOVACIA



Artik. číslo	Názov	Materiál	Povrch. úprava	∅	—	!	—	!	—	!
16 09 0 21	KONZOLA SKRYTÁ nastavov.	S	Zn	11	112	20	76	54		

KONZOLA SKRYTÁ ∅ 10/100x100



Artik. číslo	Názov	Materiál	Povrch. úprava	∅	—	!	—	!	—	!
09 19 8 xx	KONZOLA SKRYTÁ	S	C	10	100	18	100	33/88		

KONZOLA ARENA



NOVINKA

Artik. číslo	Názov	Materiál	Povrch. úprava	—	!	—	!
915 000 8 10	Arena 120	S	biela	120	37	80	
915 001 8 10	Arena 170	S	biela	170	37	120	

KONZOLA SAMSON



NOVINKA

Artik. číslo	Názov	Materiál	Povrch. úprava	—	!	—	!
915 002 x 0	Samson 300	S	Zn, biela	300	30	210	
915 003 x 0	Samson 400	S	Zn, biela	400	30	270	
915 004 0 00	Samson 500	S	Zn, biela	500	30	330	

KONZOLA



Artik. číslo	Názov	Materiál	Povrch. úprava	—	!	—	!
16 09 8 10	KONZOLA 100x75	S	biela, hnedá	100	75		
16 09 8 11	KONZOLA 125x100	S	biela, hnedá	125	100		
16 09 8 12	KONZOLA 150x125	S	biela, hnedá	150	125		
16 09 8 17	KONZOLA 225x200	S	biela, hnedá	225	200		
16 09 8 13	KONZOLA 250x200	S	biela, hnedá	250	200		
16 09 8 14	KONZOLA 350x300	S	biela, hnedá	350	300		
16 09 8 15	KONZOLA 200x150	S	biela, hnedá	200	150		
16 09 8 16	KONZOLA 250x300	S	biela, hnedá	250	300		
16 09 8 18	KONZOLA 175x150	S	biela, hnedá	175	150		
16 09 8 19	KONZOLA 300x250	S	biela, hnedá	300	250		
16 09 8 20	KONZOLA 400x350	S	biela, hnedá	400	350		
16 09 8 21	KONZOLA 450x400	S	biela, hnedá	450	400		

KONZOLA JUTTA



NOVINKA

Artik. číslo	Názov	Materiál	Povrch. úprava	—	!	—	!
915 005 8 x 0	JUTTA 115	S	biela, čierna	115	13	115	
915 005 7 x 0	JUTTA 180	S	biela, čierna	180	13	130	
915 00x 8 10	JUTTA 230	S	biela, čierna	230	13	180	

KONZOLA WRM 800



NOVINKA

Artik. číslo	Názov	Materiál	Povrch. úprava	—	!	—	!
16 09 2 5x	WRM800.250	S	Pat na Ms, Te	250	46	175	
16 09 2 0x	WRM800.200	S	Pat na Ms, Te	200	46	140	
16 09 1 5x	WRM800.150	S	Pat na Ms, Te	150	46	115	

PODPERA TROJUHOLNÍKOVÁ



Artik. číslo	Názov	Materiál	Povrch. úprava	∅	!	!
16 xx x xx	PODPERA TROJUHOL. MALÁ	P	biela, hnedá, čierna, buk, *	27	22	27
16 18 9 xx	PODPERA TROJUHOL. VEĽKÁ	P	biela, hnedá, čierna, buk, *	20	43	20
16 18 9 9x	PODPERA POD POLICU DUO	P	biela, hnedá, čierna, buk, *	32	21	32

UPEVNŔOVACÍ ELEMENT



Artik. číslo	Názov	Materiál	Povrch. úprava	∅	!	!
16 18 9 xx	UPEVNŔOVACÍ ELEMENT	P	biela, hnedá, čierna, buk	11	17	22 14/23

PODPERA POD TYČ OVÁL/KRUH



Artik. číslo	Názov	Materiál	Povrch. úprava	∅	!	!
29 12 7 10	PODPERA POD TYČ OVÁL	P	biela	-	14	26 47
29 12 1 xx	PODPERA POD TYČ	P	biela, hnedá, čierna	15	11/4	35 -

PODPERA POD ŠAT. TYČ



Artik. číslo	Názov	Materiál	Povrch. úprava	∅	!	!
29 12 8 39	PODPERA POD ŠAT. TYČ 2 kotlíky	Zn	Nim	12	19	40
29 12 6 18	PODPERA POD ŠAT. TYČ 3 diery	Zn	Ni	13	19	43
29 12 8 40	PODPERA POD ŠAT. TYČ 2 kotlíky	Zn	Ni	12	19	44

SKRIŔOVÁ RUŽICA



Artik. číslo	Názov	Materiál	Povrch. úprava	∅	!
29 12 2 x0	SKRIŔOVÁ RUŽICA POLENÁ	P	biela, hnedá, čierna	25/58	15
29 12 0 x0	SKRIŔOVÁ RUŽICA PLNÁ	P	biela, hnedá, čierna	25/58	15

DRŽIAK ZADNÉHO ČELA



Artik. číslo	Názov	Materiál	Povrch. úprava	∅	!	!
16 18 9 70	DRŽIAK ZADNÉHO ČELA	Zn	Ni	58	17	23

UPEVNŔOVACÍ TROJUHOLNÍK



Artik. číslo	Názov	Materiál	Povrch. úprava	∅	!	!
16 18 9 5x	UPEVNŔOVACÍ TROJUH. so skrut.	S, P	biela, hnedá, buk, T	10	13	15
16 18 9 5x	UPEVNŔOVACÍ TROJUHOLNÍK bez skrut.	P	biela, hnedá, buk, T	10	13	15

DRŽIAK ŠAT. TYČE



Artik. číslo	Názov	Materiál	Povrch. úprava	∅	!	!
-	DRŽIAK ŠAT. TYČE	P, S	Cr, C	70	15	60

ŠATNÍKOVÁ TYČ



Artik. číslo	Názov	Materiál	Povrch. úprava	∅	!	!
15 5x 8 xx	ŠATNÍKOVÁ TYČ	S	Nim, lak	*	15	30

PODPERKA POD SKLO



Artik. číslo	Názov	Materiál	Povrch. úprava	∅	!	!
16 01 0 10	PODPERKA POD SKLO	S, P	Zn	5	26	12 10

PODPERKA



Artik. číslo	Názov	Materiál	Povrch. úprava	∅	!	!
16 01 0 20	PODPERKA 5/10x23,4 Zn	S	Zn	5/10	23	
16 01 7 04	PODPERKA CIPK. Zn 5/3	S	Zn	3/5	18	
16 01 7 03	PODPERKA POLICE Zn 5/5	S	Zn	5/7	16	
16 01 7 02	PODPERKA S NÁVLEKOM	S, P	Zn	5/7	16	

PODPERKA



Artik. číslo	Názov	Materiál	Povrch. úprava	∅	!	!	!
16 01 0 17	PODPERKA S 1 HROTOM	Zn	Ni	5	-	-	-
16 01 0 14	PODPERKA S 2 HROTI	Zn	Ni	5	-	-	-

DRŽIAK KDC



Artik. číslo	Názov	Materiál	Povrch. úprava	∅	!	!	!
09 95 8 38	DRŽIAK KDC	S	Ni	5	320	-	-

REKTIFIKAČNÉ KOVANIE



Artik. číslo	Názov	Materiál	Povrch. úprava	!	!	!
16 03 9 xx	REKTIFIKAČNÉ KOVANIE	S, P	biela, hnedá, čierna, *	52	38	49

ZÁVESNÉ KOVANIE



Artik. číslo	Názov	Materiál	Povrch. úprava	!	!	!
16 03 6 10	REKTIFIKAČNÉ KOVANIE	S, P	Zn, C	60	18/32	39/44

PODPERKA ZRKADLA

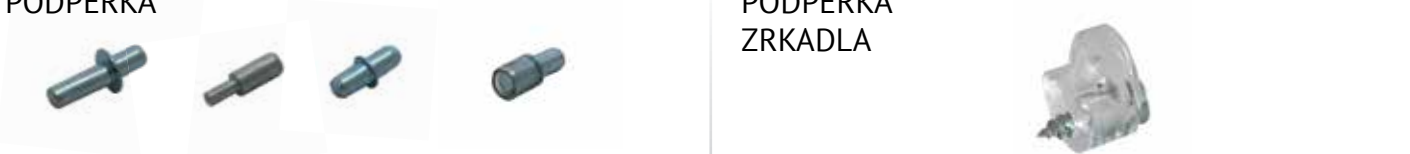

Artik. číslo	Názov	Materiál	Povrch. úprava	∅	!
16 01 0 09	PODPERKA ZRKADLA 4+ SKRUTKA	P, S	T	13	7/4
16 01 0 13	PODPERKA ZRKADLA 3+ SKRUTKA	P, S	T	13	7/3

PODPERKOVÁ SPONA



Artik. číslo	Názov	Materiál	Povrch. úprava	∅	!	!	!
10 25 2 xx	PODPERKOVÁ SPONA	S	G	3	*	-	14

DRŽIAK KDC MALÝ



Artik. číslo	Názov	Materiál	Povrch. úprava	∅	!	!	!
09 95 8 41	KDC DRŽIAK MALÝ	S	Zn	?	639	5	34

MONTÁŽNY UHOLNÍK



Artik. číslo	Názov	Materiál	Povrch. úprava	!	!	!
16 18 7 1x	MONTÁŽNY UHOLNÍK	S, P	Zn, C	25	20	25

LIŠTA K ZÁVESNÉMU KOVANIU





Artik. číslo	Názov	Materiál	Povrch. úprava	!	!	!
16 03 6 00	LIŠTA K ZÁVES. KOVANIU	S	Zn	250	39	5

NOVINKA

ZABUDOVANÁ ZÁSUVKA

 2x230 V

 1 x USB

 2 x AUDIO

 1x RJ45



Artik. číslo	Názov	Materiál	Povrch. úprava	∅	!	!
16 00 2 55	PREDLŽOVAČ ZÁPUSTNÝ 2+USB	AL	Crn	266/223	130/108	65
16 00 2 59	PREDLŽOVAČ ZÁPUSTNÝ 3x230	AL	Crn	266/223	130/108	65

ZABUDOVANÁ ZÁSUVKA

 3x230 V



Artik. číslo	Názov	Materiál	Povrch. úprava	∅	!	!
16 00 2 54	PREDLŽOVAČ ZÁPUSTNÝ 3 ČIERNY	PVC	čierna	99/130	270	
16 00 2 56	PREDLŽOVAČ ZÁPUSTNÝ 3 Crm	PVC	Crn	99/130	270	

ZABUDOVANÁ ZÁSUVKA

 3x230 V



Artik. číslo	Názov	Materiál	Povrch. úprava	∅	!	!
16 00 2 57	PREDLŽOVAČ ZÁPUSTNÝ ÚZKY 3	AL	Crn	71,4/84,4	268	

ZABUDOVANÁ ZÁSUVKA

 1x230 V

 1 x USB 5V

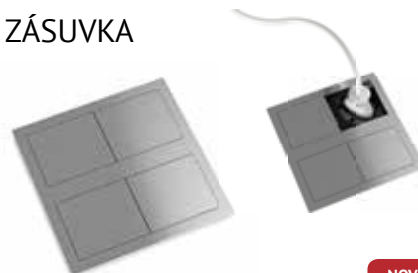

NOVINKA

Artik. číslo	Názov	Materiál	Povrch. úprava	∅	!	!
16 00 6 60	VERSAHIT	S	li	117	117	40

PRECHODKA KÁBLA P



Artik. číslo	Názov	Materiál	Povrch. úprava	∅	!	!
16 04 0 x0	PRECHODKA KÁBLA P	P	C	60/70	21	

PRECHODKA KÁBLA



Artik. číslo	Názov	Materiál	Povrch. úprava	∅	!	!
16 04 9 x1	PRECHODKA KÁBLA ∅ 60	Zn, P	Crn, Nim	60/68	68	15
16 04 9 x0	PRECHODKA KÁBLA ∅ 80	Zn, P	Crn, Nim	80/90	90	15

PRECHODKA KÁBLA 905



Artik. číslo	Názov	Materiál	Povrch. úprava	∅	!	!
16 04 9 05	PRECHODKA KÁBLA 905	P	C	74/55	11	

PRECHODKA KÁBLA Q

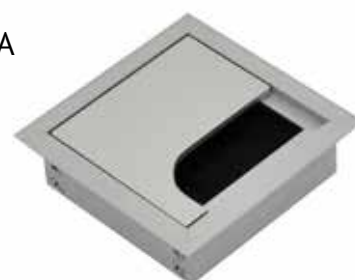

Artik. číslo	Názov	Materiál	Povrch. úprava	∅	!	!
16 00 5 01	PRECHODKA KÁBLA	Zn	Crn	80	80	24

PRECHODKA KÁBLA P



Artik. číslo	Názov	Materiál	Povrch. úprava	∅	!	!
-	PRECHODKA KÁBLA P	P	Cr,C	152	62	22

PRECHODKA KÁBLA Q



Artik. číslo	Názov	Materiál	Povrch. úprava	∅	!	!
16 04 5 00	PRECHODKA KÁBLA	Zn	Crn	100	80	24
16 00 4 0x	PRECHODKA KÁBLA	Zn	Crn, čierna	160	80	24
16 04 5 28	PRECHODKA KÁBLA	Zn	Crn	280	80	24
16 04 5 50	PRECHODKA KÁBLA	Zn	Crn	500	80	24

BOTNÍKOVÉ KOVANIE 1 pol.



Artik. číslo	Názov	Materiál	Povrch. úprava	l	h
16 09 0 14	BOTNÍKOVÉ KOVANIE 1 pol.	P	biela	250	14

BOTNÍKOVÉ KOVANIE 2 pol.



Artik. číslo	Názov	Materiál	Povrch. úprava	l	h
16 09 0 13	BOTNÍKOVÉ KOVANIE 2 pol.	P	biela	300	20

BOTNÍKOVÉ KOVANIE 3 pol.



Artik. číslo	Názov	Materiál	Povrch. úprava	l	h
16 09 0 12	BOTNÍKOVÉ KOVANIE 3 pol.	P	biela	300	25

NK 460 BRZD. ROZPERA



Artik. číslo	Názov	Materiál	Povrch. úprava	l	h
16 18 9 20	NK 460 BRZD. ROZPERA	S, P	Ni, hnedá	275	-

NK 462 ROZPERA VYKL. DVERÍ



Artik. číslo	Názov	Materiál	Povrch. úprava	Ø	l
16 15 7 1x	NK 462 ROZPERA VYKL. DVERÍ	S, P	Zn, biela	-	163

BRZDIACA ROZPERA



Artik. číslo	Názov	Materiál	Povrch. úprava	l	h
16 06 2 1x	BRZDIACA ROZPERA	S	Ni, biela	275	-

PLYNOVÁ ROZPERA



Artik. číslo	Názov	Materiál	Povrch. úprava	l	h
16 19 0 01	PLYNOVÁ ROZPERA 50N	S, P	Zn, C		
16 19 0 02	PLYNOVÁ ROZPERA 60N	S, P	Zn, C		
16 19 0 03	PLYNOVÁ ROZPERA 80N	S, P	Zn, C		
16 19 0 04	PLYNOVÁ ROZPERA 100N	S, P	Zn, C		
16 19 0 05	PLYNOVÁ ROZPERA 120N	S, P	Zn, C		
16 19 0 06	PLYNOVÁ ROZPERA 150N	S, P	Zn, C		

BAROVÁ ROZPERA



Artik. číslo	Názov	Materiál	Povrch. úprava	l	h
16 00 1 16	BAROVÁ ROZPERA 60N	S, P	Zn, C		
16 00 1 17	BAROVÁ ROZPERA 80N	S, P	Zn, C		

VZPERA L, P



Artik. číslo	Názov	Materiál	Povrch. úprava	l	h
16 15 7 2x	VZPERA L, P	S, P	Zn	200	20

VEDENIE NA CHLADNIČKY



Artik. číslo	Názov	Materiál	Povrch. úprava	l	h
16 18 9 10	VEDENIE NA CHLADNIČKY	P	biela	110	22

MAGNETICKÁ SKLAPKA



NOVINKA*

Artik. číslo	Názov	Materiál	Povrch. úprava	+	!	⊕	⊖
16 10 9 xx	MAGNET. SKLAPKA TOKOZ	S, P	biela, hnedá, čierna	52	21	14	
16 10 9 14	MAGNET. SKLAPKA MALÁ	S, P	biela	45	15	14	
NEW	MAGNET. SKLAPKA KOVOVÁ*	S	Ni	45	15	13	

MAGNETICKÁ SKLAPKA DVOJITÁ PUSCH



Artik. číslo	Názov	Materiál	Povrch. úprava	+	!	⊕	⊖
16 10 9 02	MAGNETICKÁ SKLAPKA DVOJITÁ	S, P	čierna	71	60	16	64

MECHANICKÁ SKLAPKA



NOVINKA*

Artik. číslo	Názov	Materiál	Povrch. úprava	+	!	⊕	⊖
NEW	MECHANICKÁ SKLAPKA	S, P	Zn	31	32	14	25
NEW	MECHANICKÁ SKLAPKA 2	S, P	Zn	45	21	14	-

MAGNETICKÁ SKLAPKA PUSCH



Artik. číslo	Názov	Materiál	Povrch. úprava	+	!	⊕	⊖
16 10 9 12	MAGNETICKÁ SKLAPKA	S, P	biela	38	60	16	-

BEZPEČNOSTNÝ POPRUH



Artik. číslo	Názov	Povrch. úprava	+	!	⊕	⊖
09 99 9 63	BEZPEČNOSTNÝ POPRUH	šedá	-	14	150	

BAJONETOVÝ ZÁVES



Artik. číslo	Názov	Materiál	Povrch. úprava	+	!	⊕	⊖
12 09 7 00	BAJONETOVÝ ZÁVES	S	Zn	2	58	15	2

NK 918/70



Artik. číslo	Názov	Materiál	Povrch. úprava	+	!	⊕	⊖
16 16 9 21	NK 918/70	S	Zn	1,5	70	16	1,5

ZARÁŽKA



Artik. číslo	Názov	Materiál	Povrch. úprava	+	!	⊕	⊖
16 23 0 40	ZARÁŽKA UHOLNÍKOVÁ	S	Zn	0,9	40	13	10
16 23 0 00	ZARÁŽKA OBLÁ	S	Zn	0,9	25	18	11

BEZPEČNOSTNÝ UHOLNÍK



Artik. číslo	Názov	Materiál	Povrch. úprava	+	!	⊕	⊖
09 99 9 62	BEZPEČNOSTNÝ UHOLNÍK	S	Zn	2	77	15	31

ROHOVÝ PLECH INTERIÉR



Artik. číslo	Názov	Materiál	Povrch. úprava	+	!	⊕	⊖
16 03 7 00	ROHOVÝ PLECH	Zn	Zn	1,5	40	50	32

UHOLNÍK



Artik. číslo	Názov	Materiál	Povrch. úprava	+	!	⊕	⊖
16 16 2 01	UHOLNÍK 35x35 NK 909	S	Zn	1,5	35	16	35
16 16 2 14	UHOLNÍK 40x40x2	S	Ni	2	40	20	40
16 16 2 16	UHOLNÍK 60x60x2	S	Ni	2	60	20	60
16 16 2 18	UHOLNÍK 80x80x2	S	Ni	2	80	20	80
16 16 2 20	UHOLNÍK 100x100x2	S	Ni	2	100	20	100
16 16 2 22	UHOLNÍK 120x120x2	S	Ni	2	120	20	120

ZÁVESNÝ EXCENTER S NASTAVENÍM



Artik. číslo	Názov	Materiál	Povrch. úprava	∅		
16 07 6 90	ZÁVESNÝ EXCENTER S NASTAVENÍM	S, P	hnedá	35	12	
16 00 0 60	ZÁVESNÝ EXCENTER S NASTAVENÍM	S, P	biela	35	12	

EXCENTER V PLASTOVOM PÚZDRE



Artik. číslo	Názov	Materiál	Povrch. úprava	∅		
*	EXCENTER V PLASTOVOM PÚZDRE	P, Zn	C	-	-	-

EXCENTER ∅ 10



Artik. číslo	Názov	Materiál	Povrch. úprava	∅		
*	EXCENTER ∅ 10	Zn	Zn	10	-	*

EXCENTER ∅ 15



Artik. číslo	Názov	Materiál	Povrch. úprava	∅		
*	EXCENTER ∅ 15	Zn	Zn	15/16	-	*

KONFIRMÁT



Artik. číslo	Názov	Materiál	Povrch. úprava	∅		
43 10 7 40	KONFIRMÁT 5x40 Zn	Zn	S	5	40,*	
43 10 7 78	KONFIRMÁT 6,3x50 Zn	Zn	S	6,3	50,*	
43 10 7 75	KONFIRMÁT 7x50 Zn	Zn	S	7	50,*	

SPOJOVACIA SKRUTKA



Artik. číslo	Názov	Materiál	Povrch. úprava	∅		
43 01 7 43	SPOJOVACIA SKRUTKA M4 2x15 M4x30	S	Ni	4	30	
43 01 7 46	SPOJOVACIA SKRUTKA M6 2x15 M6x30	S	Ni	6	30	

SKRUTKA DO DREVA



Artik. číslo	Názov	Materiál	Povrch. úprava	∅		
*	SKRUTKA DO DREVA	S	Zn	*	*	-

OBOJSTRANNÉ TIAHLO



Artik. číslo	Názov	Materiál	Povrch. úprava	∅		
*	OBOJSTRANNÉ TIAHLO	S	Zn	*	*	-

TIAHLO DLHÉ



Artik. číslo	Názov	Materiál	Povrch. úprava	∅		
*	TIAHLO DLHÉ	S, P	Zn	*	34	-

TIAHLO KRÁTKE



Artik. číslo	Názov	Materiál	Povrch. úprava	∅		
*	TIAHLO KRÁTKE	S, P	Zn	*	20-28	-

SKRUTKA METRICKÁ



Artik. číslo	Názov	Materiál	Povrch. úprava	∅		
*	SKRUTKA METRICKÁ	S	Zn	M4	*	-

SKRUTKA DO SADROKARTÓNU



Artik. číslo	Názov	Materiál	Povrch. úprava	∅		
*	SKRUTKA DO SADROKARTÓNU	S	?	*	*	-

KOMBINOVANÁ SKRUTKA



Artik. číslo	Názov	Materiál	Povrch. úprava	∅		
43 01 0 01	KOMBINOVANÁ SKRUTKA Zn	S	Zn	M4	20	-
46 00 0 01	KOMBINOVANÁ SKRUTKA Zn	S	Zn	M4	40	-
46 11 6 60	KOMBINOVANÁ SKRUTKA Zn	S	Zn	M6	60	-
46 10 8 60	KOMBINOVANÁ SKRUTKA Zn	S	Zn	M8	60	-
46 10 8 80	KOMBINOVANÁ SKRUTKA Zn	S	Zn	M8	80	-
46 10 8 10	KOMBINOVANÁ SKRUTKA Zn	S	Zn	M8	100	-

IMBUSOVÝ KLÚČ



Artik. číslo	Názov	Materiál	Povrch. úprava	∅			!
18 02 7 00	IMBUSOVÝ KLÚČ L 4	S	Zn	4	-	-	-
18 02 7 01	IMBUSOVÝ KLÚČ Z 4	S	Zn	4	-	-	-
18 02 7 02	IMBUSOVÝ KLÚČ L 3	S	Zn	3	-	-	-
18 03 7 00	IMBUSOVÝ KLÚČ L 5	S	Zn	5	-	-	-

ZÁVRTNÁ MATICA KUŽELOVÁ



Artik. číslo	Názov	Materiál	Povrch. úprava	∅			!
43 13 2 05	ZÁVRTNÁ MATICA M6x13 imbus	S	Zn	M6	15	-	-
43 13 2 09	ZÁVRTNÁ MATICA M8x14 209	S	Zn	M8	14	-	-
43 13 5 14	ZÁVRTNÁ MATICA pr. 12/M6	S	P	M6	12	-	-
43 13 5 15	ZÁVRTNÁ MATICA M10/20	S	Zn	M10	20	-	-

KLINCE STAVEBNÉ



Artik. číslo	Názov	Materiál	Povrch. úprava	∅			!
45 00 0 20	KLINCE STAVEBNÉ 20 mm čierne	S	Zn	1,4	20	-	-
45 00 0 21	KLINCE STAVEBNÉ 1,4x25 mm čierne	S	Zn	1,4	35	-	-
45 00 0 28	KLINCE STAVEBNÉ 1,4x30 mm čierne	S	Zn	1,4	30	-	-

DREVENÝ KOLÍK



Artik. číslo	Názov	Materiál	Povrch. úprava	∅			!
16 19 0 xx	DREVENÝ KOLÍK	W	buk	10	*	-	-
16 19 8 xx	DREVENÝ KOLÍK	W	buk	8	*	-	-
16 19 6 xx	DREVENÝ KOLÍK	W	buk	6	*	-	-

KRYTKA DREVENÁ



Artik. číslo	Názov	Materiál	Povrch. úprava	∅			!
*	KRYTKA DREVENÁ	W	*	10- 39	8	-	-

SPOJOVAČ M6



Artik. číslo	Názov	Materiál	Povrch. úprava	∅			!
16 03 1 x0	SPOJOVAČ M6	S	Zn	65, 100, 120, 150 mm	-	-	-

EUROSKRUTKA



Artik. číslo	Názov	Materiál	Povrch. úprava	∅			!
43 13 9 03	EUROSKRUTKA 6x13	S	Zn	6,2	11,5	-	-
43 11 2 63	EUROSKRUTKA 6/10 ZH POZI zb	S	Zn	6	10	-	-
43 11 2 69	EUROSKRUTKA 6/11/7 ZHX zb	S	Zn	6	11	-	-
43 11 2 71	EUROSKRUTKA 6/9/7 ZH križ Zn	S	Zn	6	9	-	-
43 11 2 72	EUROSKRUTKA 6/19/7 ZH križ Zn	S	Zn	6	19	-	-
43 11 2 66	EUROSKRUTKA 6,3/13 ZH POZI zb	S	Zn	3,3	13	-	-

KRYT NA SKRUTKU 4126



Artik. číslo	Názov	Materiál	Povrch. úprava	∅			!
43 10 0 00	KRYT NA SKRUTKU 4126	S	Zn	10	5/10	-	-

PLASTOVÝ KOLÍK



Artik. číslo	Názov	Materiál	Povrch. úprava	∅			!
16 19 9 10	PLASTOVÝ KOLÍK	P	biely	6,5	40	-	-

KRYTKA PLASTOVÁ



Artik. číslo	Názov	Materiál	Povrch. úprava	∅			!
*	KRYTKA PLASTOVÁ	P	C	*	-	-	-

HMOŽDINKA



Artik. číslo	Názov	Materiál	Povrch. úprava	∅			!
16 20 0 06	HMOŽDINKA 6	P	šedá	6	30	-	-
16 20 0 08	HMOŽDINKA 8	P	šedá	8	40	-	-
16 20 0 10	HMOŽDINKA 10	P	šedá	10	50	-	-
16 20 0 12	HMOŽDINKA 12	P	šedá	12	60	-	-

LEPIDLO TUBA



Artik. číslo	Názov	∅	!
46 00 0 32	LEPIDLO TUBA	14 ml	-

KS1

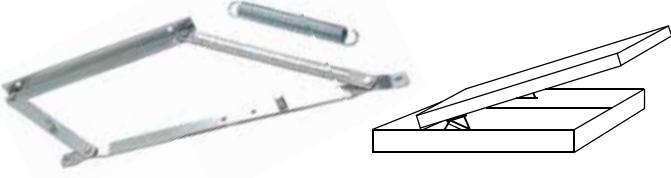

Artik. číslo	Názov	Materiál	Povrchová úprava	!	!	!
16 09 0 01	KS 1 POSTELOVÉ KOVANIE	S	Zn			

KP1

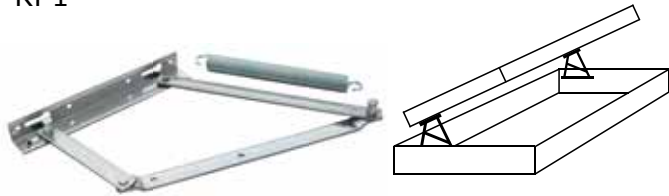

Artik. číslo	Názov	Materiál	Povrchová úprava	!	!	!
16 09 0 00	KP 1 POSTELOVÉ KOVANIE bočné, malé	S	Zn			

KP2



Artik. číslo	Názov	Materiál	Povrchová úprava	!	!	!
16 09 0 02	KP 2 POSTELOVÉ KOVANIE čelné	S	Zn			

KP3

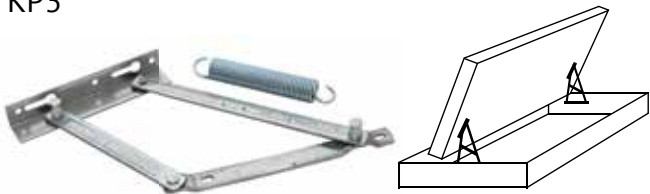

Artik. číslo	Názov	Materiál	Povrchová úprava	!	!	!
16 09 0 03	KP 3 POSTELOVÉ KOVANIE bočné	S	Zn			

KP4

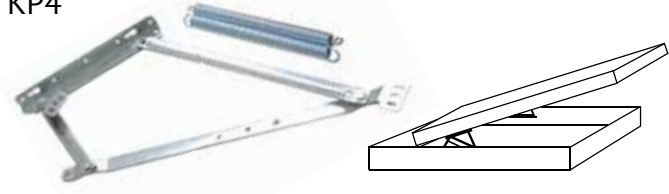

Artik. číslo	Názov	Materiál	Povrchová úprava	!	!	!
16 09 0 04	KP 4 POSTELOVÉ KOVANIE dvojložkové	S	Zn			

KP6



Artik. číslo	Názov	Materiál	Povrchová úprava	!	!	!
16 09 0 06	KP 6 POSTELOVÉ KOVANIE polohovacie	S	Zn			

HREBEŇOVÉ KOVANIE
SK117



Artik. číslo	Názov	Materiál	Povrch. úprava	!	!	!
16 09 7 03	HREBEŇOVÉ KOVANIE	S	Zn	130/127	26/15	10

POSTELOVÉ KOVANIE
SK318

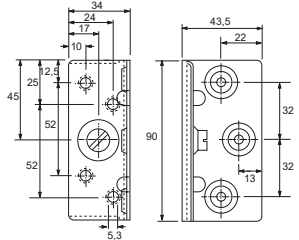

Artik. číslo	Názov	Materiál	Povrch. úprava	!	!	!
16 09 7 08	POSTELOVÉ KOVANIE SPOJOVACIE	S	Zn	90	34	43,5

POSTELOVÉ KOVANIE
SK319

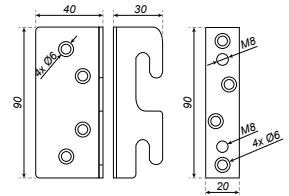

Artik. číslo	Názov	Materiál	Povrch. úprava	!	!	!
NEW	POSTELOVÉ KOVANIE - SPOJOVACIE	S	Zn	90	40	30/20

POSTELOVÉ KOVANIE
STREDOVÉ
SK118

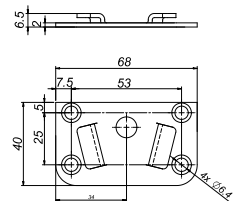

Artik. číslo	Názov	Materiál	Povrch. úprava	!	!	!
16 09 7 04	POSTELOVÉ KOVANIE - STREDOVÉ	S	Zn	69/67,5	38,5	38

POSTELOVÉ KOVANIE
NA ROŠT
SK 321

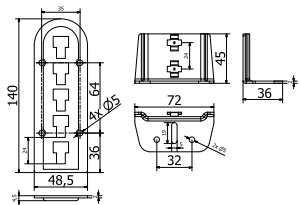

Artik. číslo	Názov	Materiál	Povrch. úprava	!	!	!
16 00 1 30	Spojovacie kovanie polohovacie	S	Zn	140	48,5	45

VÝŠKOVÝ STAVAČ
VALČEK



Artik. číslo	Názov	Materiál	Povrch. úprava	!	!	!	∅
13 00 3 44	VÝŠKOVÝ STAVAČ	P	biela	154	77	55	-
13 00 3 45	OPORNÝ VALČEK	P	biela	-	-	35	30

POSTELOVÉ KOVANIE KP9

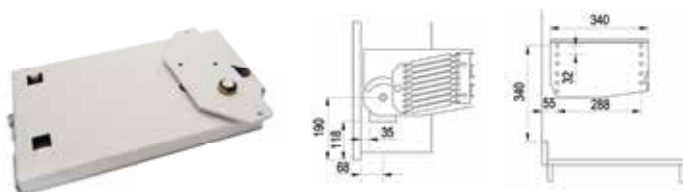

Artik. číslo	Názov	Materiál	Povrchová úprava
16 00 1 68	POSTELOVÉ KOVANIE KP9	S	Zn

POSTELOVÉ KOVANIE DO SKRINE SK310



NOVINKA

Artik. číslo	Názov	Materiál	Povrchová úprava
	POSTELOVÉ KOVANIE DO SKRINE SK310	S	Zn

ROHOVNÍK



Artik. číslo	Názov	Materiál	Povrch. úprava	+	—	!	
10 38 8 xx	ROHOVNÍK	S	C	2	177	125	50

ROHOVNÍK- FINES



Artik. číslo	Názov	Materiál	Povrch. úprava	+	—	!	
10 38 8 3x	ROHOVNÍK- FINES	S	C	3	243	50	100

VETRACIA MRIEŽKA



Artik. číslo	Názov	Materiál	Povrch. úprava	+	—	!	
89 00 0 11	Mriežka vetracia	AL	elox. hliník	400	60		
20 02 0 03	Mriežka vetracia	AL	bronz	400	60		
89 00 0 12	Mriežka vetracia	AL	elox. hliník	500	60		
89 00 0 33	Mriežka vetracia	AL	biela	500	60		
89 00 0 29	Mriežka vetracia	AL	bronz	500	60		
89 00 0 09	Mriežka vetracia	AL	elox. hliník	600	60		
89 00 2 35	Mriežka vetracia	AL	biela	600	60		
89 00 2 37	Mriežka vetracia	AL	kartáč. hliník	600	60		
89 00 0 13	Mriežka vetracia	AL	elox. hliník	800	60		
89 00 0 14	Mriežka vetracia	AL	elox. hliník	1000	60		
89 00 0 19	Mriežka vetracia	AL	biela	400	80		
89 00 0 20	Mriežka vetracia	AL	bronz	400	80		
20 03 3 00	Mriežka vetracia	AL	chróm lesklý	480	80		
20 03 0 00	Mriežka vetracia	AL	chróm matný	480	80		
89 00 2 36	Mriežka vetracia	AL	elox. hliník	600	80		
89 00 2 38	Mriežka vetracia	AL	kartáč. hliník	600	80		
89 00 2 33	Mriežka vetracia	AL	elox. hliník	800	80		
89 00 0 42	Mriežka vetracia	AL	biela	800	80		
89 00 2 39	Mriežka vetracia	AL	kartáč. hliník	800	80		
89 00 2 34	Mriežka vetracia	AL	elox. hliník	1000	80		
89 00 0 31	Mriežka vetracia	AL	biela	1000	80		
89 00 2 40	Mriežka vetracia	AL	kartáč. hliník	1000	80		

PLECH POSTELE



Artik. číslo	Názov	Materiál	Povrch. úprava	+	—	!	
16 00 1 82	PLECH POSTELE	S	C	?	?	?	?

SOKEL



Obj. číslo	Typ	Prevedenie	Balenie
16 00 1 92	Profil L20	ner. brúsený	4 bm
16 00 1 91	Profil L20	hlin. brúsený	4 bm
16 00 2 22	Profil L20	hlin. natural	4 bm
16 00 2 90	Profil L20	biela lesklá	4 bm
16 00 1 92	Profil L20	ner. brúsený	4 bm
16 00 1 91	Profil L20	hlin. brúsený	4 bm
16 00 2 22	Profil L20	hlin. natural	4 bm
16 00 2 90	Profil L20	biela lesklá	4 bm
16 00 1 92	Profil L20	ner. brúsený	4 bm
16 00 1 91	Profil L20	hlin. brúsený	4 bm
16 00 2 22	Profil L20	hlin. natural	4 bm
16 00 2 90	Profil L20	biela lesklá	4 bm
PRÍSLUŠENSTVO			
	Koncovka H-100	šedá	1 ks
	Koncovka H-101	šedá	1 ks
	Koncovka H-102	šedá	1 ks

TESNIACI PROFIL L15 A

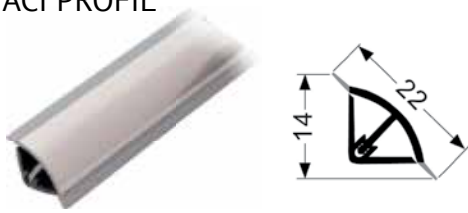

Obj. číslo	Typ	Prevedenie	Balenie
1 600 781	tesniaci profil	nerez	3 bm
1 600 782	tesniaci profil	hliník	3 bm
PRÍSLUŠENSTVO			
1 600 562	koncovka	šedá	1 ks
1 600 462	vnútorný roh	šedý	1 ks
1 600 362	vonkajší roh	šedý	1 ks

TESNIACI PROFIL L15 B

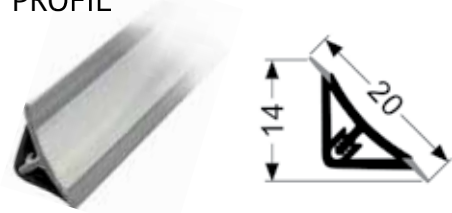

Obj. číslo	Typ	Prevedenie	Balenie
1 600 781	tesniaci profil	nerez	3 bm
1 600 782	tesniaci profil	hliník	3 bm
PRÍSLUŠENSTVO			
1 600 562	koncovka	šedá	1 ks
1 600 462	vnútorný roh	šedý	1 ks
1 600 362	vonkajší roh	šedý	1 ks

TESNIACI PROFIL L230

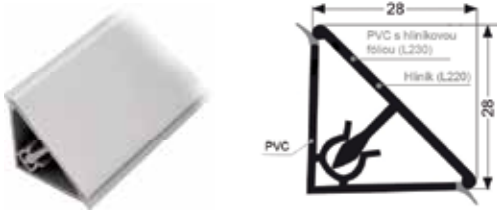

Artik. číslo	Typ	Prevedenie	Balenie
1 600 195	tesniaci profil	nerez brúsený	4 bm
1 600 196	tesniaci profil	hliník brúsený	4 bm
PRÍSLUŠENSTVO			
1 600 197	elementy	svetlošedé	1 set
1 600 198	elementy	tmavošedé	1 set

TESNIACI PROFIL L11

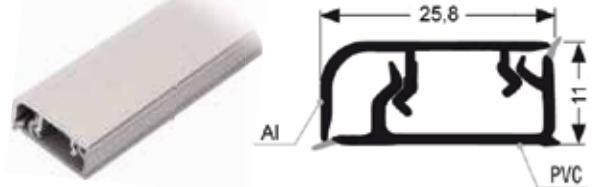

Artik. číslo	Typ	Prevedenie	Balenie
1 600 187	tesniaci profil	hliník brúsený	4 bm
1 600 188	tesniaci profil	nerez brúsený	4 bm
PRÍSLUŠENSTVO			
1 600 190	elementy - na ležato	svetlošedé	1 set
1 600 118	elementy - na ležato	tmavošedé	1 set
1 600 189	elementy - na ležato	biele	1 pár

TESNIACI PROFIL L20

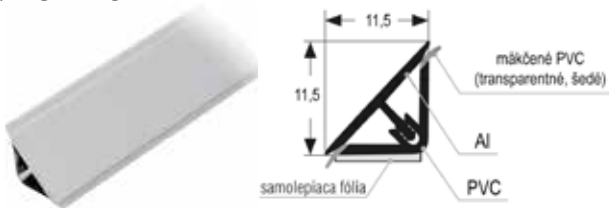

Artik. číslo	Typ	Prevedenie	Balenie
16 00 1 92	Profil L20	ner. brúsený	4 bm
16 00 1 91	Profil L20	hlin. brúsený	4 bm
16 00 2 22	Profil L20	hlin. natural	4 bm
16 00 2 90	Profil L20	biela lesklá	4 bm
NEW	Profil L20	antracit	4 bm
PRÍSLUŠENSTVO			
16 00 1 93	elementy k profilu L20	sv. šedá	1 sada
16 00 1 94	elementy k profilu L20	tm. šedá	1 sada
16 00 3 25	elementy k profilu L20	biela	1 sada
NEW	elementy k profilu L20	antracit	1 sada
16 00 2 46	koncovka k profilu L20	tm. šedá	1 ks
16 00 2 91	koncovka k profilu L20	biela	1 ks
NEW	koncovka k profilu L20	antracit	1 ks
16 00 2 47	roh vnútorný	tm. šedá	1 ks
16 00 2 92	roh vnútorný	biela	1 ks
NEW	roh vnútorný	antracit	1 ks
16 00 2 48	roh vonkajší	tm. šedá	1 ks
16 00 2 93	roh vonkajší	biela	1 ks
NEW	roh vonkajší	antracit	1 ks

TESNIACI PROFIL L16/L19

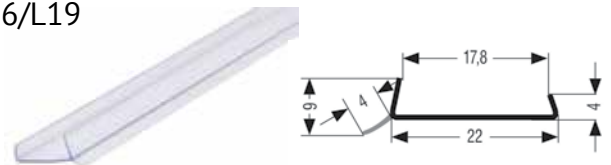

Artik. číslo	Typ	Prevedenie	Balenie
89 01 1 01	Profil L16 - pre DTD 16 mm	transparent	3 bm
89 01 1 00	Profil L19 - pre DTD 18 a 19 mm	transparent	3 bm

TESNIACI PROFIL L1812



Artik. číslo	Typ	Prevedenie	Balenie
16 00 9 84	Profil L1812	ner. brúsený	4 bm
16 00 9 83	Profil L1812	hlin. brúsený	4 bm

OKOPOVÝ PLECH



Artik. číslo	Typ	Prevedenie	Balenie
16 00 2 33	Okopový plech H-100 mm	ner. brúsený	1 bm
16 00 2 72	Okopový plech H-100 mm	hlin. brúsený	1 bm
16 00 2 40	Okopový plech H-150 mm	ner. brúsený	1 bm
16 00 3 82	Okopový plech H-200 mm	ner. brúsený	1 bm

OCHRANNÝ PROFIL

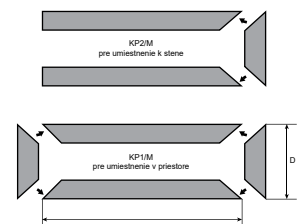

Názov	L	D	Povrch. úprava
Ochranný profil KP1/M	920	36	hliník brúsený, nerez brúsený
Ochranný profil KP1/M	920	38	hliník brúsený, nerez brúsený
Ochranný profil KP2/M	600	36	hliník brúsený, nerez brúsený
Ochranný profil KP2/M	600	38	hliník brúsený, nerez brúsený

SAMOLEPIACE KRYTKY

V ponuke máme samolepiace krytky pre viac než 200 bežne používaných dekorov. Krytky sú dostupné v priemeroch 10, 14 (skladom), 20, 25 a 40mm.

V prípade záujmu o kompletný vzorkovník samolepiacich krytiiek prosím kontaktujte nášho obchodného zástupcu.

Číslo	Názov	Kronospan	Kronopol	Pfleiderer	Egger	DDL
1	Akácia	D 9755	D 7780	R 37005	H 1615	435
2	Akácia škoricová	K 004				
3	Alabaster	0514 7031	U 1301 U 3114 U 162	U 11509	U 104	
4	Antracit	0164			U 963	
5	Antracit 1	0162		U 12290 U 12018	U 960	
200	Ateliér svetlý	4298				
201	Ateliér tmavý	4299				
6	Atlantic			U 0741		
7	Baklažánová		U 3116		U 330	
202	Betón hladký			S 60010		
8	Betón svetlý			R 48010		535
9	Betón tmavý		D 3827			
203	Běžová Came				U 216	
10	Biela	0101, 8100, 8685, 6459	U 511, K 110, U 3293	W 10140	W 980 SM	
11	Biela Alaska					
12	Biela alpská studená	8681	U8681	U 11027		
13	Biela lesklá			U 11209HG	W 1100	
14	Biela perlička		K 101 PE	U 11026	W 1000	
15	Biela raster	8685	K 101SE		W 1000ST22 W 1000ST38	
204	Bielo - sivá			U 11500		
16	Bodega jasná		D 3160 D 3316			
17	Borgsjo					548
205	Borovica Aland biela				H 3430	
18	Borovica bielená		D 3168			
19	Borovica Bramberg			R 55008	H 1487	
20	Borovica čokoládová					527
21	Borovica Jackson					534
22	Borovica medová					
23	Borovica nórska čierna		D 4103		H 3081	
24	Brest Amsterdam		D 3193			
25	Brest Baron		D 3191	R 37001		
26	Brest Baron Trufel		D 3167 D 3273 D 3799	R 37003		
206	Brest Libert	K 018		R 20147		546
207	Brest Libert svetlý	K 017		R 42006		
208	Brest Libert strieborný	K 019				
27	Brest Lombardia	D 5116 D 5194				
28	Brest Ovid		D 3163	R 3219		
29	Brest tmavo-hnedý mys				H 3766	
30	Breza Helsinky				H 3758	
31	Breza Ikea					
32	Breza Island hnedá				H 3711	
33	Breza Mainau	1715		R 36002	H 1733	380
34	Breza otcova			R 3222		
35	Breza otcova tmavá	D 5122	D 3817		H 1151	454
209	Buk Artisan	K 014				
36	Buk Bavaria				H 1511	
37	Buk Bordeaux	K 013	D 3806			529
38	Buk Brussel		D 3805			
210	Buk Fjord svetlý			R 24029		
39	Buk Iconic				H 3991	
40	Buk Samerberg	0381			H 1582	463, 383
211	Buk škandinávsky svetlý			R 24030		
41	Buk Vienna	K 012	D 3809			
42	Buk Zürich	9419	D 3807			
43	Calvados	D 1937	D 9300			456
44	Cappucino		U 3053	U 16179	U 200	
45	Cappucino 1	U 9553				
212	Carbon Marine Wood	K 016		R 20033	H 3342	
46	Coco-bolo prírodné	D 8995				
47	Congo			U 1191	U 727	
213	Congo 2			U 16002	U 727	
48	Crossline karamel	8362				
49	Čadič		U 3189			
50	Čerešňa	1792				
214	Čerešňa "dosková"			R 42009		
51	Čerešňa Kingston tabak	8618				
52	Čerešňa Oxford	0088	D 088			
53	Červená			U 17005	U 321	
54	Červená Burgund	U 5517	U 2656		U 311	
55	Červená ohnivá				U 323	
57	Čierna		U 190 SE		U 999	
58	Čierna hladká				U 999	
59	Čierna lesklá			U 12007	U 999	
60	Čierna perlička	0190	U 190 PE		U 999	
61	Dub		D 9103		H 3395	
62	Dub americký		R 3101			
63	Dub antracit		D 3165			
64	Dub Aragon prírodný			R 30039	H 3170	
65	Dub Arlington prírodný	D 8995				
66	Dub bardolino šedý			R 20128	H 1146	



Číslo	Názov	Kronospan	Kronopol	Pfleiderer	Egger	DDL
215	Dub Bordeaux		D 3349	R 20074		544
68	Dub Brunico		D 3264 D 3313		H 3326 H 1212	
69	Dub Calais	9103 0757				
216	Dub Calais svetlý				H 1319	
217	Dub Camargue					
70	Dub Cantori	D 5112			H 3309 H 3451	
218	Dub Craft tabak	K 004				
71	Dub Cremona pieskový		D 3275			525
72	Dub divoký	K 003	D 3192	3217		
73	Dub divoký tabak		D 2453		H 1113	
74	Dub Dublin					
75	Dub Ferrara svetlý				H 1334	
76	Dub Ferrara tmavý				H 1137	
77	Dub Figaro		D 3315		H 1486	
78	Dub grafit			R 20065		
219	Dub Halifax biely				H 1176	
220	Dub Halifax prírodný				H 1180	
221	Dub Halifax tabak				H 1181	
222	Dub Hamilton prírodný				H 3303	
223	Dub Higland				H 3362	
79	Dub horský svetlý	0740				
224	Dub kamenný	5527				
80	Dub krajinný	9614				
81	Dub kráľovský	D 5117	D 2840			
225	Dub Lancelot			R 20027		
82	Dub latte			R 20064		
226	Dub Lefkas tmavý			R 20134		
83	Dub Lindberg	D 8431	D 8567	R 20095	H 1444	
84	Dub Madrid		D 3801	R 20021		538
85	Dub mestský ustricový	K 003	D 5194 D 3276		H 3730	545
86	Dub mliečny	D 8622				
87	Dub Nebraska				H 1399	
88	Dub Nebraska prírodný			R 20119	H 3303	
89	Dub New York		D 3823			528
90	Dub Orleans hnedý				H 3047 H 3133	521
227	Dub Palero svetlý		D 2609			
91	Dub Paris		D 2039 D 3195	R 3127		
92	Dub Rome		D 3800			
93	Dub rustikálny	D 1903 D 9102	D 3055			354
228	Dub rustikálny					
94	Dub San Remo pieskový	D 4139				
228	Dub skalný	5529				
95	Dub Sonoma	3025	D 3025	R 20128	H 1145	541, 517
96	Dub Sonoma tabak	K 007		R 20031		526
97	Dub Stockholm	8445	D 8417 D 3821			
98	Dub šedý	7504 K 002			H 3090	519
99	Dub Traviata		D 3268			
229	Dub Urban jantárový			R 55007		
100	Dub Warsaw		D 3312			540
101	Dub Winchester	D 8617			H 3382	
102	Fialová tmavá		U 3115			
103	Fineline krémový	D 8547	D 3158	R 55006	H 3433 H 3450	
230	Fineline mokka	8548				
231	Fuksiová			U 17019		
104	Gaštan	D 8620 D 8948	D 2360 D 9451			
105	Gaštan Bern		D 3820		H 1213	
106	Gaštan Lvov		D 3818			
107	Gaštan Toulouse		D 3819			
232	Grafit svetlý	0171	U 3057		U 732	
233	Grafit šedý					
234	Hacienda biela				H 3078	
108	Hikora Montreal		D 4205			
109	Hikora Vancouver		D 4207			
110	Hiteak	K 018	D 3813	R 55004		
111	Hliník	0881	D 881	F 70004	F 509	
113	Hnedá močiarna		U 185			
114	Hruška	0375				
115	Hruška divoká	D 1625	D 2361			455
116	Jaboloň Locarno	1792	D 1972			509
117	Jaboloň Locarno tmavá	1972				
118	Jaseň Cassino hnedý	8545				
119	Jaseň coimbra	8653		R 38002	H 1277	
120	Jaseň eko		D 3166			
121	Jaseň Lyon pieskový	D 8921 D 6596	D 2843	R 35018		
122	Jaseň Moscow		D 1926			
123	Jaseň Navara				H 1250	
124	Javor	1738		R 27024		
235	Javor kráľovský			R 27001	H 1521	
125	Javor Vancouver	1783	D 9475			542
126	Jeľša	D 685	D 9310			398, 214

Číslo	Názov	Kronospan	Kronopol	Pfleiderer	Egger	DDL
127	Jeľša horská	D 1912 D 9411			H 3113	
128	Kašmír			U 12168	U 702	
129	Laliová	U 8534				
130	Lan béžový				F 425	
131	Lan šedý				F 426	
133	Legno svetlé	D 8915	D 2381			
134	Legno tabak		D 8417	R 3081		
135	Legno tmavé	8914	D 2380			
136	Leguánová			U 1100		
137	Limba		D 2266	H 1116	H 1199	
138	Limetka					
139	Mahagón	D 402	D 466		H 3080	
140	Makasar	D 8994			H 3025	
141	Makasar Cayu	D 8425				
142	Makasar Cejlon	D 8971				
236	Makasar PF			R 50009		
143	Merano prírodné	7935			H 1636	
237	Mušta					
144	Nabucco			R 3144		
145	Navarra sivá					543
146	Ohnivá	U 7176				
238	Oliva Španielsko			R 50030		
147	Oranžová	U 551	U 3113			
148	Oranžová Global			U 1678		
149	Orech Aida tabak	D 8405				
150	Orech Avignon tmavý			R 35013		
151	Orech Baltimore					
152	Orech Barcelona		D 3813		H 3773	
153	Orech Caravaggio		D 9164 D 2611			
154	Orech Dijon prírodný				H 3734	
155	Orech Ecco	D 9462	D 722 D 9163			452
156	Orech macchiato	D 7947	D 2842 D 2419		H 1114 H 3398	518
157	Orech Marino		D 2841 D 3810			
158	Orech Nice				H 3700	
159	Orech Pacific prírodný				H 1101	
160	Orech Sankt Moritz		D 3829			
239	Orech Select svetlý	K 008		R 24009		
240	Orech Select teplý	K 020		R 30011		
161	Orech stredný	D 9459				
241	Orech tabak				H 3704	
162	Orech Tennessee				H 3703	
163	Orech tmavý	D 1925	D 9450			
164	Orech viva	5503				
165	Palisander Himalaya		D 8568	R 30013		
166	Pínia avola Champagne				H 1476	
167	Pínia avola sivá			R 55032		
168	Pompei			R 3218		
169	Rockpile			R 50027		
170	Ružová		U 3118			
171	Sangha wenge			R 50004	H 3058	
172	Sherwood moka	D 5105	D 3159		H 3325	
173	Sherwood svetlý			R 3140		
174	Sivá	0112	U 112		U 708	
242	Sivá 2					
175	Sivá grafitová			U 12257		
176	Sivá lúčna		U 544	U 15190	U 717	
243	Sivá perlová				U 763	
177	Sivá piesková					
178	Sivá platinová	0197				
179	Sivá svetlá	U 7045	U 119	U 16003	U 156	
180	Slivka Wallis	D 8880	D 8880 BS	R 35003		474
181	Smrekove Sibiu			R 55028		
182	Smrekovec biely		D 2605	R 55001	H 1424	475
183	Safránová			U 1510		
244	Texwood biely			F 73051		
245	Tirano pearwood				H 3114	
184	Titán				F 501	
185	Tortona prírodná				H 3331	
186	Urbano prírodné				H 3070	
187	Vanilka	9569			U 108	
188	Vanilka 2	0564	U 3261	U 11523	U 222	
246	Vintage Marine Wood	K 015			H 3154	511
189	Wenge	D 8621		R 20158 R 27017		450
190	Wenge	D 9763 D 8625				
191	Wenge amari	D 9182				468
192	Woodline creme	8443			H 1401	
193	Zebrano klasik	8601				
194	Zebrano pieskové			R 42009		
195	Zelená limetka					
197	Zelený hrášok			U 19508		
198	Žltá 2	U 134				
199	Žltá Milano	7123				

VETRÁK Ø 35
VETRÁK Ø 40
VETRÁK Ø 50



Artik. číslo	Názov	Materiál	Povrch. úprava	Ø	!
20 11 8 10	VETRÁK Ø 35	P	biela	35/38	7
20 10 8 xx	VETRÁK Ø 40	P	C	40/45	8
20 00 0 ox	VETRÁK Ø 50	P	C	50/60	17

TLMIČ



Artik. číslo	Názov	Materiál	Povrch. úprava	Ø	!
16 22 0 07	TLMIČ D 7	P	T	7	- 1,5
16 22 0 08	TLMIČ D 8	P	T	8	- 1,5
16 22 0 10	TLMIČ D 10	P	T	10	- 1,5

REGÁLOVÝ SYSTÉM



DRÔTENÁ POLICA



NOVINKA

Artik. číslo	Názov	Materiál	Povrch. úprava	!
91 50 30 800	DRÔTENÁ POLICA 800x300	S	biela	800 300
91 50 31 100	DRÔTENÁ POLICA 800x400	S	biela	800 400

NOSNÍKY PRE
REGÁLOVÝ SYSTÉM



NOVINKA

Artik. číslo	Názov	Materiál	Povrch. úprava	!	nosnosť
91 50 30 400	NOSNÍK PRE DRÔTENÉ POLICE 320	S	biela	320	30 kg
91 50 30 600	NOSNÍK PRE DRÔTENÉ POLICE 420	S	biela	420	30 kg
91 50 45 359	NOSNÍK 200	S	biela	200	-
91 50 45 360	NOSNÍK 250	S	biela	250	-
91 50 45 361	NOSNÍK 300	S	biela	300	-
91 50 45 362	NOSNÍK 350	S	biela	350	-
91 50 45 363	NOSNÍK 400	S	biela	400	-
91 50 45 366	U-NOSNÍK 170	S	biela	170	-
91 50 45 367	U-NOSNÍK 220	S	biela	220	-
91 50 45 368	U-NOSNÍK 270	S	biela	270	-
91 50 45 369	U-NOSNÍK 370	S	biela	370	-
91 50 45 370	U-NOSNÍK 470	S	biela	470	-
91 50 45 371	STRANOVÝ NOSNÍK 180	S	biela	180	-
91 50 45 372	STRANOVÝ NOSNÍK 230	S	biela	230	-
91 50 45 373	STRANOVÝ NOSNÍK 280	S	biela	280	-
91 50 45 374	STRANOVÝ NOSNÍK 330	S	biela	330	-
91 50 45 375	STRANOVÝ NOSNÍK 380	S	biela	380	-

PLECHOVÁ POLICA



NOVINKA

Artik. číslo	Názov	Materiál	Povrch. úprava	!
91 59 22 242	PLECHOVÁ POLICA 800x250	S	biela	800 250
91 59 22 285	PLECHOVÁ POLICA 800x300	S	biela	800 300
91 59 22 287	PLECHOVÁ POLICA 800x350	S	biela	800 350

LIŠTA PRE REGÁLOVÝ SYSTÉM



NOVINKA

Artik. číslo	Názov	Materiál	Povrch. úprava	!
91 50 45 351	JEDNORADOVÁ LIŠTA 1000	S	biela	1000 18 12
91 50 45 352	JEDNORADOVÁ LIŠTA 1500	S	biela	1500 18 12
91 50 45 353	JEDNORADOVÁ LIŠTA 2000	S	biela	2000 18 12
91 50 45 355	DVOJRADOVÁ LIŠTA 1000	S	biela	1000 25 12
91 50 45 356	DVOJRADOVÁ LIŠTA 1500	S	biela	1500 25 12
91 50 45 357	DVOJRADOVÁ LIŠTA 2000	S	biela	2000 25 12

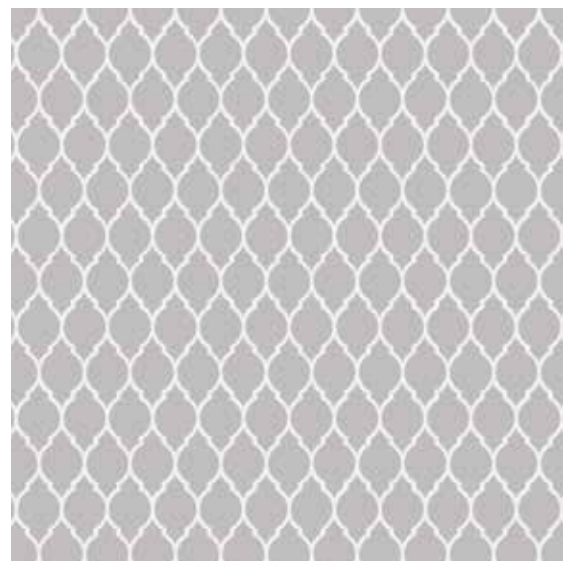

ZÁVESY, PÁNTY A ZÁMKY
HINGES AND LOCKS

			114, 116	118
		nastaviteľný uhol otvárania 135°-165°	114, 116	118
		rovný záves	115, 117	118, 119
		uhlový -15°	-	119
		uhlový 15°		119
		uhlový 24°		119
		uhlový 30°	114, 116	119
		uhlový 45°	114, 116	119
				119
		Touch opening	115	120
		záves pre rohové skrinky	117	119
		barový záves		119
		záves pre zabudovanú chladničku		119
		záves pre dvere s hliníkovým rámom		119

Záves Sensys 8645i a 8675

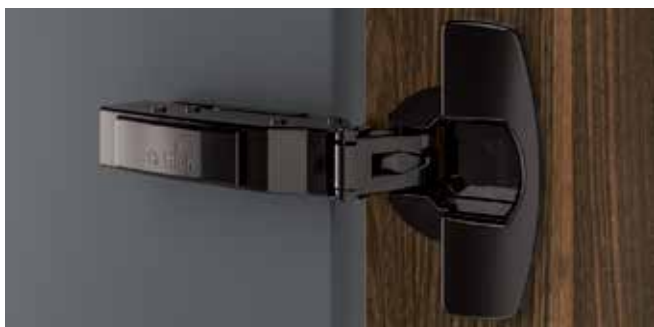

- pre hrúbku dverí 15 - 24 mm
- uhol otvorenia 110° resp. 85° pri použití obmedzovača (809 072 540)
- farba: čierny obsidián

Typ		Artik. číslo	
		8645i s tlmením	8675 bez pružiny
Naložený	B 12,5 mm	809 091 738	809 091 741
Polonaložený	B 3 mm	809 091 739	809 091 742
Vložený	B -4 mm	809 091 740	809 091 743

Záves Sensys 8631i a 8661 pre dvere s veľkou hrúbkou



- pre hrúbku dverí 15 - 32 mm
- uhol otvorenia 95°
- farba: čierny obsidián

Typ		Artik. číslo	
		8631i s tlmením	8661 bez pružiny
Naložený	B 12,5 mm	809 091 753	809 091 758
Polonaložený	B 3 mm	809 091 755	809 091 759
Vložený	B -4 mm	809 091 756	809 091 760

Záves Sensys W30 8639i a 8669 pre korpusový uhol 30°



- pre hrúbku dverí 15 - 28 mm
- uhol otvorenia 95°
- farba: čierny obsidián

Typ		Artik. číslo	Artik. číslo
		8639i s tlmením	8669 bez pružiny
Naložený	B 2 mm	809 091 745	809 091 749

Záves Sensys 8657i a 8687 s nulovým presahom do svetlosti



- pre hrúbku dverí 15 - 32 mm
- uhol otvorenia 165° resp. 105° alebo 120° pri použití obmedzovača (809 090 756), prípadne 90° alebo 135° pri použití obmedzovača (809 090 864)
- farba: čierny obsidián

Typ		Artik. číslo	
		8657i s tlmením	8687 s pružinou
Naložený	B 12,5 mm	809 091 767	809 091 769
Polonaložený	B 3 mm	809 091 768	809 091 770

Záves Sensys 8646i a 8676 pre dvere s malou hrúbkou



- pre hrúbku dverí 10 - 19 mm
- uhol otvorenia 110°
- farba: čierny obsidián

Typ		Artik. číslo	
		8646i s tlmením	8676 bez pružiny
Naložený	B 12,5 mm	809 091 761	809 091 764
Polonaložený	B 3 mm	809 091 762	809 091 765
Vložený	B -4 mm	809 091 763	809 091 766

Záves Sensys W45 8639i a 8669 pre korpusový uhol 45°



- pre hrúbku dverí 15 - 28 mm
- uhol otvorenia 95°
- farba: čierny obsidián

Typ		Artik. číslo	Artik. číslo
		8639i s tlmením	8669 bez pružiny
Naložený	B 9 mm	809 091 746	809 091 750
	B -2 mm	809 091 747	809 091 751

Záver Sensys W90 8639i a 8669 pre korpusový uhol 90°



- pre hrúbku dverí 15 - 28 mm
- uhol otvorenia 95°
- farba: čierny obsidián

Typ	Artik. číslo	Artik. číslo	
		8639i s tlmením	8669 bez pružiny
Vložený	B 4 mm	809 091 748	809 091 752

Podložka pre Sensys



- farba: čierny obsidián

Typ	Artik. číslo	
podložka "3D" s predmontovanými eurošrutkami	D 0 mm	809 091 803
podložka "3D" s predmontovanými eurošrutkami	D 1,5 mm	809 091 804
lineárna podložka k nasrutkovaniu	D 1,5 mm	809 091 817
lineárna podložka k nasrutkovaniu	D 3 mm	809 091 818

Krytka pre misku a ramienko závesu Sensys



- farba: čierny obsidián

Typ	Artik. číslo
oceľová krytka na ramienko s vyrazeným logom Hettich (okrem závesov 8657i, 8657 a 8687)	809 091 821
plastová krytka na ramienko s potlačeným logom (pre 8657i, 8657 a 8687)	809 099 871
oceľová krytka pre misku	809 091 822

Obmedzovač



Obr. č.	Typ	Artik. číslo
1.	Obmedzovač zo 110° na 85° pre 8645i	809 072 540
2.	Obmedzovač zo 110° na 85° pre 8646i	809 076 440
3.	Obmedzovač zo 95° na 85° pre W 8639i	809 072 541
4.	Obmedzovač zo 95° na 85° pre 8638i	809 072 542
5.	Obmedzovač zo 165° na 105°/120° pre 8657i	809 090 756
6.	Obmedzovač zo 165° na 90°/135° pre 8657i	809 090 864
7.	Obmedzovač zo 95° na 85° pre 8631i	809 103 006

Push to open magnet k priskrutkovaniu



Zdvih	Artik. číslo		
	antracit	svetlosivá	biela
Krátky (cca 14 mm)*	809 089 629	809 089 604	809 089 590
Dlhý (cca 17 mm)*	809 089 630	809 089 605	809 089 591

*dvere na závesoch bez pružiny sa otvoria viac

Pre bližšie informácie naskenujte



<https://goo.gl/K5A8By>

Zásev Sensys 8645i a 8675



- pre hrúbku dverí 15 - 24 mm
- uhol otvorenia 110° resp. 85° pri použití obmedzovača (809 072 540)
- farba: niklovaná

Typ		Artik. číslo	
		8645i s tlmením	8675 bez pružiny
Naložený	B 12,5 mm	809 071 205	809 071 313
Polonaložený	B 3 mm	809 071 206	809 071 314
Vložený	B -4 mm	809 071 207	809 071 315

Záves Sensys 8657i a 8687 s nulovým presahom do svetlosti



- pre hrúbku dverí 15 - 32 mm
- uhol otvorenia 165° resp. 105° alebo 120° pri použití obmedzovača (809 090 756), prípadne 90° alebo 135° pri použití obmedzovača (809 090 864)
- farba: niklovaná

Typ		Artik. číslo	
		8657i s tlmením	8687 s pružinou
Naložený	B 12,5 mm	809 099 540	809 099 660
Polonaložený	B 3mm	809 099 550	809 099 670

Záves Sensys 8631i a 8661 pre dvere s veľkou hrúbkou



- pre hrúbku dverí 15 - 32 mm
- uhol otvorenia 95°
- farba: niklovaná

Typ		Artik. číslo	
		8631i s tlmením	8661 bez pružiny
Naložený	B 12,5 mm	809 090 260	809 090 440
Polonaložený	B 3 mm	809 090 270	809 090 450
Vložený	B -4 mm	809 090 280	809 090 460

Záves Sensys 8646i a 8676 pre dvere s malou hrúbkou



- pre hrúbku dverí 10 - 19 mm
- uhol otvorenia 110°
- farba: niklovaná

Typ		Artik. číslo	
		8646i s tlmením	8676 bez pružiny
Naložený	B 12,5 mm	809 094 270	809 094 450
Polonaložený	B 3 mm	809 094 280	809 094 460
Vložený	B -4 mm	809 094 290	809 094 470

Záves Sensys W30 8639i a 8669 pre korpusový uhol 30°



- pre hrúbku dverí 15 - 28 mm
- uhol otvorenia 95°
- farba: niklovaná

Typ		Artik. číslo	Artik. číslo
		8639i s tlmením	8669 bez pružiny
Naložený	B 2 mm	809 088 016	809 088 176
Vložený	B -16 mm	809 088 017	809 088 177

Záves Sensys W45 8639i a 8669 pre korpusový uhol 45°



- pre hrúbku dverí 15 - 28 mm
- uhol otvorenia 95°
- farba: niklovaná

Typ		Artik. číslo	Artik. číslo
		8639i s tlmením	8669 bez pružiny
Naložený	B 9 mm	809 088 018	809 088 179
	B -2 mm	809 088 019	809 088 178
Vložený	B -25 mm	809 088 020	809 088 180

Záves Sensys W90 8639i a 8669 pre korpusový uhol 90°



- pre hrúbku dverí 15 - 28 mm
- uhol otvorenia 95°
- farba: niklovaná

Typ	B 4 mm	Artik. číslo	Artik. číslo
		8639i s tlmením	8669 bez pružiny
Vložený		809 088 021	809 088 181

Záves Intermat rohový 9930



- uhol otvorenia 50°/65°
- farba: niklovaná

Typ	B 24 mm	Artik. číslo
		bez pružiny
Naložený		809 090 109

Podložka pre Sensys



- farba: niklovaná

Typ		Artik. číslo
podložka "3D" s predmontovanými skrutkami	D 0 mm	809 071 655
podložka "3D" s predmontovanými skrutkami	D 1,5 mm	809 071 656
lineárna podložka k naskrutkovaniu	D 1,5 mm	809 075 095
lineárna podložka k naskrutkovaniu	D 3 mm	809 075 096
podložka k naskrutkovaniu	D 0 mm	809 071 575
podložka k naskrutkovaniu	D 1,5 mm	809 071 576

Krytka pre miskú a ramienko závesu Sensys



- farba: niklovaná

Typ	Artik. číslo
oceľová krytka na ramienko s vyrazeným logom Hettich (okrem závesov 8657i, 8657 a 8687)	809 088 250
plastová krytka na ramienko s potlačeným logom (pre 8657i, 8657 a 8687)	809 099 871
oceľová krytka pre miskú	809 088 252

Obmedzovač



Obr. č.	Typ	Artik. číslo
1.	Obmedzovač zo 110° na 85° pre 8645i	809 072 540
2.	Obmedzovač zo 110° na 85° pre 8646i	809 076 440
3.	Obmedzovač zo 95° na 85° pre W 8639i	809 072 541
4.	Obmedzovač zo 95° na 85° pre 8638i	809 072 542
5.	Obmedzovač zo 165° na 105°/120° pre 8657i	809 090 756
6.	Obmedzovač zo 165° na 90°/135° pre 8657i	809 090 864
7.	Obmedzovač zo 95° na 85° pre 8631i	809 103 006

Adaptér k nalepeniu pre Sensys



- nutné doobjednať podložku pre záves, str. 115

Typ	B 3 mm	Artik. číslo	Artik. číslo
		Záves	Adaptér
Naložený		809 099 550	809 081 923
Polonaložený		809 099 550	809 081 923
Vložený	B -4 mm	809 073 607	809 081 923

Pre bližšie informácie naskenujte



<https://goo.gl/K5A8By>

Záves ST naložený - klipový



Typ	Artik. číslo		Priemer misky
	s tlmením	bez tlmenia	
na naskrutkovanie		12 00 0 28	35 mm

Záves Basic naložený - slide-on



Typ	Artik. číslo		Priemer misky
	s tlmením	bez tlmenia	
na naskrutkovanie	1 2 00 0 16	12 04 1 35	35 mm

Záves ST polonaložený - klipový



Typ	Artik. číslo		Priemer misky
	s tlmením	bez tlmenia	
na naskrutkovanie		12 00 0 10	35 mm

Záves Basic polonaložený - slide-on



Typ	Artik. číslo		Priemer misky
	s tlmením	bez tlmenia	
na naskrutkovanie	1 200 016	12 04 1 36	35 mm

Záves ST vložený - klipový



Typ	Artik. číslo		Priemer misky
	s tlmením	bez tlmenia	
na naskrutkovanie		12 00 0 09	35 mm

Záves Basic vložený - slide-on



Typ	Artik. číslo		Priemer misky
	s tlmením	bez tlmenia	
na naskrutkovanie	12 00 0 18	12 04 1 27	35 mm
na euroskrutku		1 2 04 6 77	35 mm

Záves ST 170° - klipový



Typ	Artik. číslo		Priemer misky
	s tlmením	bez tlmenia	
na naskrutkovanie		1 2 00 0 11	35 mm

Záves Basic rovný - slide-on



Typ	Artik. číslo		Priemer misky
	s tlmením	bez tlmenia	
vložený		12 04 1 15	35 mm
polonaložený		12 00 1 00	35 mm

Záves ST rovný - klipový



Typ	Artik. číslo		Priemer misky
	s tlmením	bez tlmenia	
vložený		12 04 1 39	35 mm
polonaložený		12 04 1 23	35 mm

Záves Basic barový



Typ	Artik. číslo		Priemer misky
	pravý	ľavý	
barový	12 04 1 26	12 04 1 25	35 mm

Záves ST rohový - klipový



Typ	Artik. číslo		Priemer misky
	s tlmením	bez tlmenia	
rohový		12 04 1 24	35 mm

Záves Miniprimat na sklo



Typ	Artik. číslo		Priemer misky
	s tlmením	bez tlmenia	
naložený		12 04 8 00	26 mm
vložený		12 05 8 00	26 mm
rovný		12 04 6 00	26 mm

Záves ST uhlový - klipový



Typ	Artik. číslo		Priemer misky
	s tlmením	bez tlmenia	
-15°		12 00 0 13	35 mm
15°		12 00 0 12	35 mm
24°		12 00 5 00	35 mm
30°		12 00 6 00	35 mm
45°		12 01 3 00	35 mm

Krytka na záves na sklo



Typ	Artik. číslo		Priemer
	čierna	chróm	
"D"	12 00 0 54	12 00 0 02	32 mm
"O"	12 00 0 01	12 00 1 02	32 mm

Záves ST na Al dvierka 20 mm klipový



Typ	Artik. číslo		Priemer misky
	s tlmením	bez tlmenia	
naložený		12 04 1 05	

Záves pre zab. chladničku - slide-on



Typ	Artik. číslo		Priemer misky
	s tlmením	bez tlmenia	
naložený		12 01 8 00	35 mm

Záves ST Touch + magnet



Typ	Artik. číslo		Priemer misky
	záves	magnet	
touch	12 04 1 04	12 00 2 00	35 mm

Tlmič Glissando pre závesy 170° ST a Basic



Uhol otvorenia	Artik. číslo	Priemer misky
170°	16 18 7 40	

Podložka Titus



Typ		Artik. číslo
BASIC na naskrutkovanie	0 mm	12 04 1 13
Miniprimat na naskrutkovanie	0 mm	12 04 1 08
BASIC na naskrutkovanie	pre rovný záves	12 04 1 15
BASIC s euroskrutkou	pre rovný záves	12 04 1 29
BASIC s euroskrutkou	2 mm	12 04 1 37
BASIC s euroskrutkou	3 mm	12 04 1 38
ST s euroskrutkou	3 mm	12 04 6 00
Miniprimat s euroskrutkou	pre rovný záves	12 04 6 84
ST na naskrutkovanie	0 mm	12 04 6 91
ST s euroskrutkou	3 mm	12 04 6 00



Tlmenie Titus (video)



Titus závesy (PDF)

Tlmič Glissando pre naložené a polonaložené závesy



Typ	Artik. číslo		Priemer misky
	biela	buk	
rohový	16 18 7 41	16 48 7 43	

Tlmič Glissando pre závesy ST a Basic



Uhol otvorenia	Artik. číslo	Priemer misky
110°	12 04 6 06	

Západka stlačná

- vytvorenie PUSH systému pre závesy a výsuvy bez tlmenia



Typ	Artik. číslo	Balenie
Západka s priamym uchytením	16 00 0 82	1 ks
Západka s priečnym uchytením	16 00 0 75	1 ks

Tlmič Airtic



Názov	Povrch. úprava	Dĺžka	Priemer	Artik. číslo
Tlmič Airtic	biely, čierny, hnedý, kalvados, javor, šedý, buk	50 mm	8 mm	16 18 5 xx
Adaptér		37 mm	-	16 18 6 xx



ZÁVES SQUARE



Artik. číslo	Názov	Materiál	Povrch. úprava	!	!	!	!
26 01 2 10	ZÁVES SQUARE L+P	Zn, S	Cr	40	48	30	16
26 01 2 02	ZÁVES BADGE L+P	Zn, S	Cr	40	48	30	16
26 01 2 11	ZÁVES SQUARE L+P	Zn, S	Cr	40	48	30	16
26 01 2 01	ZÁVES BADGE L+P	Zn, S	Cr	40	48	30	16

ZÁVES BADGE NA SKLO PRIEBEŽNÝ



Artik. číslo	Názov	Materiál	Povrch. úprava	!	!	!	!
26 01 2 13	ZÁVES SQUARE PRIEBEŽNÝ	Zn	Cr	40	14	29	16
26 00 0 02	ZÁVES BADGE PRIEBEŽNÝ	Zn	Cr	40	14	29	16
26 00 0 01	ZÁVES SQUARE PRIEBEŽNÝ	Zn	Cr	40	14	29	16
26 01 2 14	ZÁVES BADGE PRIEBEŽNÝ	Zn	Cr	40	14	29	16

ÚCHYTKA NA SKLO BADGE



Artik. číslo	Názov	Materiál	Povrch. úprava	!	!	!	!
26 01 0 01	ÚCHYTKA NA SKLO BADGE	Zn	Cr	32	26	28	
26 00 0 00	ÚCHYTKA NA SKLO SQUARE	Zn	Cr	32	26	28	
26 00 0 51	ÚCHYTKA NA SKLO BADGE	Zn	Cr	32	26	28	
26 01 0 53	ÚCHYTKA NA SKLO SQUARE	Zn	Cr	32	26	28	

ÚCHYTKA NA DVOJSKLO BADGE



Artik. číslo	Názov	Materiál	Povrch. úprava	!	!	!	!
26 01 0 54	ÚCHYTKA NA DVOJSKLO BADGE	Zn	Cr	32	26	28	
26 01 0 56	ÚCHYTKA NA DVOJSKLO SQUARE	Zn	Cr	32	26	28	
26 01 0 55	ÚCHYTKA NA DVOJSKLO BADGE	Zn	Cr	32	26	28	
26 01 0 57	ÚCHYTKA NA DVOJSKLO SQUARE	Zn	Cr	32	26	28	

ZARÁŽKA NA DVOJSKLO STREDOVÁ BADGE



Artik. číslo	Názov	Materiál	Povrch. úprava	!	!	!	!
26 01 5 12	ZARÁŽKA NA DVOJSKLO STREDOVÁ BADGE	Zn, S	Cr	40	16	30	
26 01 5 32	ZARÁŽKA NA DVOJSKLO STREDOVÁ SQUARE	Zn, S	Cr	40	16	30	
26 01 5 33	ZARÁŽKA NA DVOJSKLO STREDOVÁ SQUARE	Zn, S	Cr	40	16	30	

ZARÁŽKA NA DVOJSKLO BADGE



Artik. číslo	Názov	Materiál	Povrch. úprava	!	!	!	!
26 01 5 10	ZARÁŽKA NA SKLO BADGE	Zn	Cr	42	39	11	16
26 01 5 30	ZARÁŽKA NA SKLO SQUARE	Zn	Cr	42	39	11	16
26 01 7 10	ZARÁŽKA NA SKLO BADGE	Zn	Cr	42	39	11	16
26 01 5 31	ZARÁŽKA NA SKLO SQUARE	Zn	Cr	42	39	11	16
26 01 5 11	ZARÁŽKA NA DVOJSKLO BADGE	Zn	Cr	42	39	11	16
26 01 5 34	ZARÁŽKA NA DVOJSKLO SQUARE	Zn	Cr	42	39	11	16
26 01 5 35	ZARÁŽKA NA DVOJSKLO SQUARE	Zn	Cr	42	39	11	16

ZÁMOK NA SKLO SQUARE



Artik. číslo	Názov	Materiál	Povrch. úprava	!	!	!	!
26 01 5 00	ZÁMOK NA SKLO BADGE	Zn, S	Cr	42	30	40	
26 01 5 22	ZÁMOK NA SKLO SQUARE	Zn, S	Cr	42	30	40	
26 01 5 01	ZÁMOK NA SKLO BADGE	Zn, S	Cr	42	30	40	
26 01 5 21	ZÁMOK NA SKLO SQUARE	Zn, S	Cr	42	30	40	

ZÁMOK NA DVOJSKLO SQUARE



Artik. číslo	Názov	Materiál	Povrch. úprava	!	!	!	!
26 01 5 40	ZÁMOK NA DVOJSKLO BADGE	Zn, S	Cr	40	42	29	
26 01 5 59	ZÁMOK NA DVOJSKLO SQUARE	Zn, S	Cr	40	42	29	
26 01 5 47	ZÁMOK NA DVOJSKLO BADGE	Zn, S	Cr	40	42	29	
26 01 5 56	ZÁMOK NA DVOJSKLO SQUARE	Zn, S	Cr	40	42	29	

DIZA ZÁVES
+DIZA ZÁVES
PRIEBEŽNÝ



Artik. číslo	Názov	Materiál	Povrch. úprava	40	17	31	16
06 40 x 0x	DIZA ZÁVES	Zn	G	40	17	31	16
26 66 x 0x	DIZA ZÁVES PRIEBEŽNÝ	Zn	G	40	17	31	16

DIZA ÚCHYTKA



Artik. číslo	Názov	Materiál	Povrch. úprava	41	25	30
06 50 x 00	DIZA ÚCHYTKA	Zn	G	41	25	30

ČIPKOVÝ ZÁVES
+ÚCHYTKA



Artik. číslo	Názov	Materiál	Povrch. úprava	6	40	11	18
26 02 2 03	ČIPKOVÝ ZÁVES L+P	S	Cr	6	40	11	18
26 02 5 03	ČIPKOVÝ ZÁVES L+P	S	Ms	6	40	11	18
26 02 7 03	ČIPKOVÝ ZÁVES L+P	S	Crn	6	40	11	18

ČIPKOVÝ ZÁVES II.
+ÚCHYTKA



Artik. číslo	Názov	Materiál	Povrch. úprava	40	12	15
26 00 8 14	ČIPKOVÝ ZÁVES L+P	S	Ni	40	12	15
26 00 8 91	ČIPKOVÝ ZÁVES L+P	S	čierna	40	12	15
26 00 8 93	ÚCHYTKA	S	Ni	40	8	15
26 00 8 92	ÚCHYTKA	S	čierna	40	8	15

ZNS



Artik. číslo	Názov	Materiál	Povrch. úprava	40	29	21
06 41 x 00	ZÁVES NA SKLO	Zn	G	40	29	21

ZÁVES NA
BAROVÉ
DVERE



Artik. číslo	Názov	Materiál	Povrch. úprava	30	-	12
12 03 9 20	NK 522	Zn, P	C	30	-	12
12 03 8 20	ZÁVES NA BAROVÉ DVERE	Zn	Zn	30	-	12

ZÁVES
TROJA



Artik. číslo	Názov	Materiál	Povrch. úprava	38	90
17 03 x 00	ZÁVES TROJA	Zn	Ms, pat	38	90

ZÁVES
SPARTA



Artik. číslo	Názov	Materiál	Povrch. úprava	38	76
17 03 x 01	ZÁVES SPARTA	Zn	Ms, pat	38	76

ZÁVES
MARK



Artik. číslo	Názov	Materiál	Povrch. úprava	36	20
17 04 x 00	ZÁVES MARK I.	S	Zn, pat	36	20
17 04 x 01	ZÁVES MARK II.	S	Zn, pat	36	28

ZÁVES NA OKNO
S HREBEŇOM
40



Artik. číslo	Názov	Materiál	Povrch. úprava	49	42
17 04 0 40	ZÁVES NA OKNO S HREBEŇOM 40	S	Zn	49	42

ZÁVES
HUNGARIA



Artik. číslo	Název	Materiál	Povrch. úprava	28		58	
17 03 x 05	ZÁVES HUNGARIA	Zn	Ms, pat				

ZÁVES
HUNGARIA
LOMENÝ



Artik. číslo	Název	Materiál	Povrch. úprava	75		30		25	
17 03 x 06	ZÁVES HUNGARIA LOMENÝ	Zn	Ms, pat						

ZÁVES
HONT



Artik. číslo	Název	Materiál	Povrch. úprava	27		80	
17 03 x 04	ZÁVES HONT	Zn	Ms, pat				

ZÁVES
TIMUR



Artik. číslo	Název	Materiál	Povrch. úprava	25		151	
17 02 x 03	ZÁVES TIMUR	Zn	Ms, pat				

ZÁVES LOMENÝ



Artik. číslo	Název	Materiál	Povrch. úprava	25		74	
17 03 x 02	ZÁVES LOMENÝ	Zn	Ms, pat				

ZÁVES
ORAVA



Artik. číslo	Název	Materiál	Povrch. úprava	8	27		76	
17 03 x 03	ZÁVES ORAVA	Zn	Ms, pat					

ZÁVES
EMANUEL



Artik. číslo	Název	Materiál	Povrch. úprava	28		68	
17 02 x 02	ZÁVES EMANUEL	Zn	Ms, pat				

ZÁVES
ANTIK



Artik. číslo	Název	Materiál	Povrch. úprava	24		57	
01 82 x 0x	ZÁVES ANTIK	Zn	G				

OZDOBNÝ
ROH



Artik. číslo	Název	Materiál	Povrch. úprava	88		88	
17 02 x 00	OZDOBNÝ ROH	Zn	Ms, pat				

ZÁVES
LARSEN



Artik. číslo	Název	Materiál	Povrch. úprava	114		68	
17 02 x 01	ZÁVES LARSEN	Zn	Ms, pat				

ZÁVES
OZDOBNÝ 20x21



NOVINKA

Artik. číslo	Název	Materiál	Povrch. úprava	20		21		2	
12 11 5 54	ZÁVES OZDOBNÝ 20x21	B	Ms						

ZÁVES
OZDOBNÝ MINI



NOVINKA

Artik. číslo	Název	Materiál	Povrch. úprava	24		23		2	
12 11 5 5x	ZÁVES OZDOBNÝ H 57	Cr, Nim, Ms							

UZÁVER
OZDOBNÝ



NOVINKA

Artik. číslo	Název	Materiál	Povrch. úprava	—	!	⊕	⊕
14 16 5 10	UZÁVER OZDOBNÝ BRONZ		bronz	29	10	3	22

ZÁVES OHNUTÝ II.
ZÁVES OHNUTÝ I.



Artik. číslo	Název	Materiál	Povrch. úprava	—	!	⊕	⊕
12 11 0 0x	ZÁVES OHNUTÝ II.	S	Zn	38	45	17	-
12 11 0 0x	ZÁVES OHNUTÝ I.	S	Zn	52	60	25	-

ZÁVES KLBOVÝ



Artik. číslo	Název	Materiál	Povrch. úprava	—	!	⊕	⊕
12 11 7 30	ZÁVES KLBOVÝ 30x30	S	Zn	30	30	4	-
12 11 7 25	ZÁVES KLBOVÝ 25x25	S	Zn	25	25	4	-

ZÁVES ROVNÝ E



Artik. číslo	Název	Materiál	Povrch. úprava	—	!	⊕	⊕
12 11 0 0x	ZÁVES ROVNÝ E	S	Zn	51	46	-	-

ZÁVES ROVNÝ



Artik. číslo	Název	Materiál	Povrch. úprava	—	!	⊕	⊕
12 11 0 00	ZÁVES ROVNÝ	S	Zn	53	2	40	-

ZÁSTRČ NÁBYTKOVÁ UZ



Artik. číslo	Název	Materiál	Povrch. úprava	—	!	⊕	⊕
13 05 7 35	ZÁSTRČ NÁBYTKOVÁ UZ 35	S	Zn	50	47	13	-
13 05 7 27	ZÁSTRČ NÁBYTKOVÁ UZ 25	S	Zn	44	42	10	-

ZÁVES
OZDOBNÝ H 52



Artik. číslo	Název	Materiál	Povrch. úprava	—	!	⊕	⊕
12 11 5 56	ZÁVES OZDOBNÝ H 52	B	Ms	80	15	1	-

ZÁVES KLAVÍROVÝ



Artik. číslo	Název	Materiál	Povrch. úprava	—	!	⊕	⊕
12 11 x xx	ZÁVES KLAVÍROVÝ	S	Ms, Ni	3500, +	32	-	-

ZÁVES KZ 60



Artik. číslo	Název	Materiál	Povrch. úprava	—	!	⊕	⊕
17 01 7 02	ZÁVES KZ 40	S	Zn	40	30	6	-

ZÁVES KZ 40



Artik. číslo	Název	Materiál	Povrch. úprava	—	!	⊕	⊕
17 01 7 00	ZÁVES KZ 60	S	Zn	60	40	8	-

ZÁVES
NK 125/16



Artik. číslo	Název	Materiál	Povrch. úprava	—	!	⊕	⊕
12 08 7 0x	ZÁVES NK 125/16	S	Zn	29	19	46	-

ZÁSTRČ NÁBYTKOVÁ



Artik. číslo	Název	Materiál	Povrch. úprava	—	!	⊕	⊕
13 05 0 70	ZÁSTRČ NÁBYTKOVÁ	S	Ni	70	15	5	-

ZÁMOK LAMA



Artik. číslo	Název	Materiál	Povrch. úprava	∅	—	!	⊕
13 01 8 00	ZÁMOK LAMA	S, Zn	Ni	17	42	40	27/29

ZÁMOK
CENTRÁLNÍ
BOČNÝ



Artik. číslo	Název	Materiál	Povrch. úprava	∅	—
13 02 3 20	ZÁMOK CENTRÁLNÍ BOČNÝ 500	S, Zn	Ni	17/40	500
13 02 3 25	ZÁMOK CENTRÁLNÍ BOČNÝ 600	S, Zn	Ni	17/40	600

ZÁMOK 640.81
NA SKLO



Artik. číslo	Název	Materiál	Povrch. úprava	∅	—	!	⊕
13 01 2 07	ZÁMOK 640.81 NA SKLO	S, Zn	Cr	19/25	54	27	38/32

ZÁMOK 750/100
NA SKLO



Artik. číslo	Název	Materiál	Povrch. úprava	∅	—	!	⊕
13 01 2 06	ZÁMOK 750/100 NA SKLO	S, Zn	Cr	18	100	25	

ZÁMOK 105
BAJONETOVÝ



Artik. číslo	Název	Materiál	Povrch. úprava	∅	—	!	⊕
13 02 3 03	ZÁMOK 105 BAJONETOVÝ	S, Zn	Ni	19	27	34	

ZÁMOK 138
STOLÍKOVÝ



Artik. číslo	Název	Materiál	Povrch. úprava	∅	—	!	⊕
13 02 3 01	ZÁMOK 138 STOLÍKOVÝ	S, Zn	Ni	19	40	28	27/30/30

ZÁMOK CENTRÁLNÍ
ČELNÝ



Artik. číslo	Název	Materiál	Povrch. úprava	∅	—
13 02 3 22	ZÁMOK CENTRÁLNÍ ČELNÝ 500	S, Zn	Ni	19	500
13 02 3 23	ZÁMOK CENTRÁLNÍ ČELNÝ 600	S, Zn	Ni	19	600

ZÁMOK x917
NA SKLO



Artik. číslo	Název	Materiál	Povrch. úprava	∅	—	!	⊕
13 01 2 04	ZÁMOK x917 NA SKLO	S, Zn	Cr	19	40	29	52/32

ZÁMOK 202
ROLETOVÝ



Artik. číslo	Název	Materiál	Povrch. úprava	∅	—	!	⊕
13 02 3 02	ZÁMOK 202 ROLETOVÝ	S, Zn	Ni	19	40/54	40	28/30/30

ZÁMOK x44D NA
KOVOVÚ SKRIŇU



Artik. číslo	Název	Materiál	Povrch. úprava	—	!
13 01 2 22	ZÁMOK x44D NA KOVOVÚ SKRIŇU	S, Zn	Cr	16/23	16/23



VÝKLOPNÉ SYSTÉMY
LIFT SYSTEMS

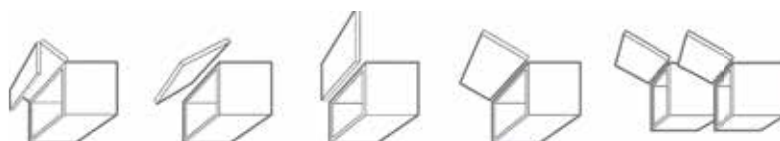

Výklopné systémy AVENTOS

	HF	HS	HL	HK	HK-S	HK-XS
Použitie						
Vysoké horné skrinky	•	•				
Stredné horné skrinky	•	•	•	•		
Nízke horné skrinky			•	•	•	•
Vysoké skrinky			•	•	•	•
Priestorové plánovanie						
Malé priestorové potreby smerom nahor	•	•		•	•	•
Stvárnenie						
Jednodielne čelo		•	•	•	•	•
Dvojdielne čelo	•					
Možnosť kombinácie s vencovými lištami alebo rampami	•	•	•	•	•	•
Rozsah výšok korpusu v mm	480 - 1040	350 - 800	300 - 580	do 600 ¹	do 400	240 - 600
Rozsah širok korpusu v mm	do 1800	do 1800	do 1800	do 1800	do 1800 ²	do 1800
Ergonómia						
Dobrá prístupnosť úchytky	•	•	•	•	•	•
Dobry prístup do vnútra skrine	•	•	•	•	•	•
Technológie pohybu						
BLUMOTION	•	•	•	•	•	•
SERVO-DRIVE	•	•	•	•		
TIP-ON				•	• ³	• ³

¹ Z ergonomického hľadiska odporúčame maximálnu výšku korpusu 600 mm. Ak bude dodržaná aj hranica faktora výkonu, môžu sa realizovať aj vyššie výklopy.

² v závislosti od faktora výkonu

³ Nedá sa kombinovať s BLUMOTION.



AVENTOS HF

Skladací výklop

- Ideálny pre vysoké dvojdielne čelá horných skriniek
- Malé priestorové potreby smerom nahor
- Umožňuje aj používanie čiel rôznej výšky



AVENTOS HS

Výkyvný výklop

- Ideálny pre veľké, jednodielne čelá horných skriniek
- Výklop sa vyklápa nad korpus
- Možnosť kombinácie aj s vencovými lištami alebo rampami



AVENTOS HL

Zdvíhací výklop

- Ideálny pre malé, jednodielne čelá vysokých a horných skriniek
- Vhodný na použitie s čelami nad nimi
- Za súvislým čelom zakrýva napr. aj elektrické zariadenia



montáž (video)



Aventos HF (PDF)



montáž (video)



Aventos HS (PDF)



montáž (video)



Aventos HL (PDF)



AVENTOS HK

Výklop

- Ideálny pre ťažké čelá horných skriniek
- Malé priestorové nároky smerom nahor
- Kompletné kovanie



AVENTOS HK-S

Malý výklop

- Ideálny pre malé čelá vysokých a horných skriniek
- Zdvíhací mechanizmus sa optimálne hodí pre malé korpusy, napr. nad chladničkou alebo potravinovou skriňou
- Kompletné kovanie



AVENTOS HK-XS

Malý výklop

- Ideálny pre malé vysoké a horné skrinky
- Aj pre korpusy s menšou svetlou hĺbkou, napr. nad kuchynským odsávačom pár
- Malé kovanie, použiteľné jednostranne i obojstranne



montáž (video)



Aventos HK (PDF)



montáž (video)



Aventos HK-S (PDF)



montáž (video)



Aventos HK-XS (PDF)

DUO / DUO FORTE



Artik. číslo	Názov	Materiál	Povrch. úprava	Kg	!	—
80 01 0 05	DUO 90°	Zn	Ni	3-15 kg	-	200-400
80 00 0 02	DUO-FORTE 90°	Zn	Ni	3-15 kg	-	200-700



DUO návod (PDF)



DUO FORTE návod (PDF)

DUO

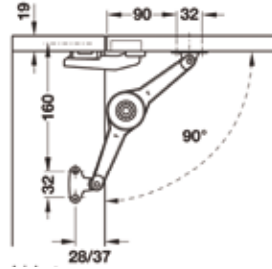

Vyklápanie smerom nahor

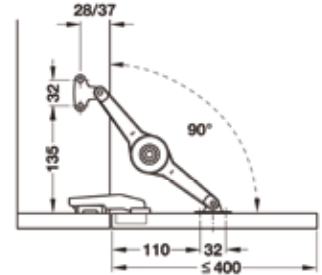

Vyklápanie smerom nadol

DUO-FORTE

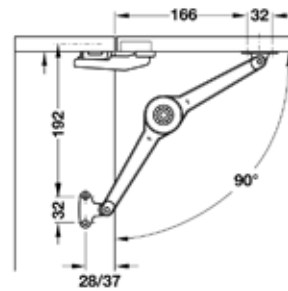

Vyklápanie smerom nahor

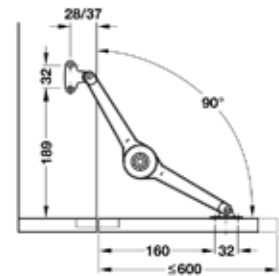

Vyklápanie smerom nadol

MAXI



MAXI návod (PDF)

Artik. číslo	Názov	Materiál	Povrch. úprava	Kg	!	—
80 00 0 07	MAXI A	Zn	Ni	1,1 - 7,1 kg*	-	300 - 1000
80 04 0 03	MAXI B	Zn	Ni	2,0 - 13,7 kg*	-	300 - 1000
80 00 0 06	MAXI C	Zn	Ni	3,6 - 21 kg*	-	300 - 1000
80 00 0 08	MAXI D	Zn	Ni	4,6 - 27,3 kg*	-	300 - 1000

* Pri uhle otvorenia 75°

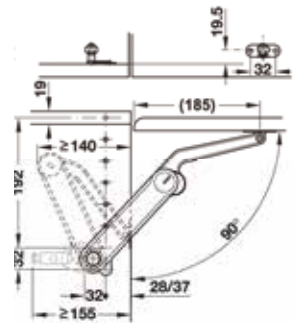
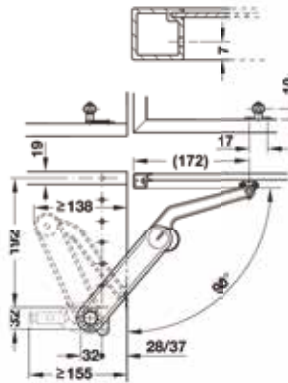

JUNIOR

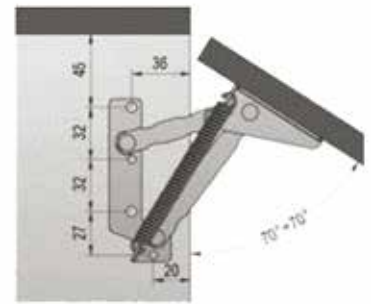
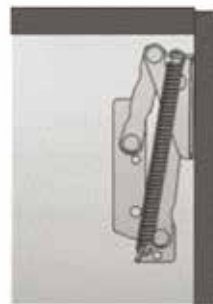

Artik. číslo	Názov	Materiál	Povrch. úprava
16 09 0 5x	JUNIOR-VÝKLOPNÉ KOVANIE	S	Ni



ZÁSUVKOVÉ SYSTÉMY
DRAWER SYSTEMS



Zásuvka ArciTech 94 mm

Prevedenie

Menovitá dĺžka (mm)	Prevedenie	
	strieborná	biela
	zásuvka	zásuvka
270	809 150 613	809 149 261
300	809 150 614	809 149 262
350	809 150 615	809 149 263
400	809 150 616	809 149 264
450	809 150 618	809 149 265
500	809 150 619	809 149 266
550	809 150 620	809 149 268
650	809 150 621	809 149 269

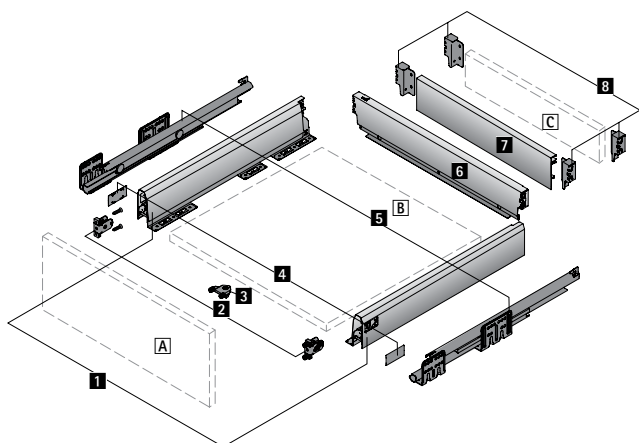

Sada obsahuje

- 1** Bočnica L+P, 1 pár
- 2** Príchyt čela na zalisovanie, 1 pár
- 4** Krytka plastová s logom Hettich, 2 ks

Nutné objednať:

5 výsuv Actro, str. 133

8 sadu držiakov chrbta 94mm (809 150 641 strieborná) alebo (809 149 279 biela)

+ stabilizátor čela (pre šírku zásuvky >600mm) 809 123 080

Zásuvka ArciTech 186 mm s relingom

Prevedenie

Menovitá dĺžka (mm)	Prevedenie			
	strieborná		biela	
	zásuvka	reling	zásuvka	reling
270	809 150 613	809 150 647	809 149 261	809 149 285
300	809 150 614	809 150 648	809 149 262	809 149 286
350	809 150 615	809 150 649	809 149 263	809 149 287
400	809 150 616	809 150 650	809 149 264	809 149 288
450	809 150 618	809 150 652	809 149 265	809 149 289
500	809 150 619	809 150 653	809 149 266	809 149 290
550	809 150 620	809 150 654	809 149 268	809 149 291
650	809 150 621	809 150 656	809 149 269	809 149 292

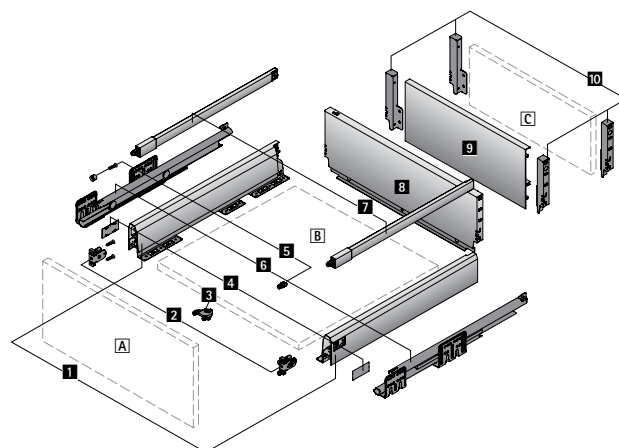

Sada obsahuje

- 1** Bočnica L+P, 1 pár
- 2** Príchyt čela na zalisovanie, 1 pár
- 4** Krytka plastová s logom Hettich, 2 ks
- 5** Príchyt relingu na zalisovanie, 2 ks
- 7** Pozdĺžny reling L+P

Nutné objednať:

6 - výsuv Actro, str. 133

10 - sadu držiakov chrbta 186mm (809 150 643 strieborná) alebo (809 149 281 biela)

3 - stabilizátor čela (pre šírku zásuvky > 600mm) 809 123 080



<https://goo.gl/LgxmSQ>



Zásuvka ArciTech 186mm s DesignSide sklo

Prevedenie

Menovitá dĺžka (mm)	strieborná*		biela*	
	zásuvka	DesignSide sklo	zásuvka	DesignSide sklo
270	809 150 613	809 122 983	809 149 261	809 122 983
300	809 150 614	809 122 984	809 149 262	809 122 984
350	809 150 615	809 122 985	809 149 263	809 122 985
400	809 150 616	809 122 986	809 149 264	809 122 986
450	809 150 618	809 122 987	809 149 265	809 122 987
500	809 150 619	809 122 988	809 149 266	809 122 988
550	809 150 620	809 122 989	809 149 268	809 122 989
650	809 150 621	809 122 990	809 149 269	809 122 990

Zásuvka ArciTech vnútorná

Prevedenie

Šírka korpusu (mm)	strieborná*	biela*	strieborná**	biela**
	čelo pre vnútornú zásuvku 94mm	čelo pre vnútornú zásuvku 94mm	čelo pre vnútornú zásuvku 186mm	čelo pre vnútornú zásuvku 186mm
300	809 122 795	809 122 804	809 122 849	809 122 858
400	809 122 796	809 122 805	809 122 850	809 122 859
450	809 122 797	809 122 806	809 122 851	809 122 860
500	809 122 798	809 122 807	809 122 852	809 122 861
600	809 122 799	809 122 808	809 122 853	809 122 862
800	809 122 800	809 122 809	809 122 854	809 122 863
900	809 122 801	809 122 810	809 122 855	809 122 864
1200	809 122 803	809 122 812	809 122 857	809 122 866

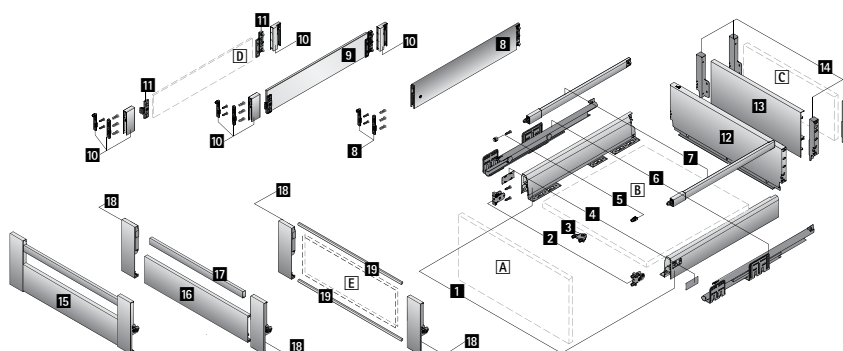

Sada obsahuje

- 1** Bočnica L+P, 1 pár
- 2** Príchyt čela na zalisovanie, 1 pár
- 4** Krytka plastová s logom Hettich, 2 ks
- 9 10** DesignSide L+P s nalepenými spojmi, 1 pár

Nutné objednať:

- + výsuv Actro, str. 133
- + sadu držiakov chrbta 186mm (809 150 643 strieborná) alebo (809 149 281 biela)
- + adaptér DesignSide (809 122 973 strieborná) alebo (809 122 975 biela)
- + stabilizátor čela (pre šírku zásuvky >600mm) 809 123 080

*Sada obsahuje

- 15** čelo pre vnútornú zásuvku bez relingu, 1ks

**Sada obsahuje

- 15** čelo pre vnútornú zásuvku s relingom, 1ks

Nutné objednať:

- + zásuvku ArciTech 94mm alebo 186mm s relingom str., 1 komplet
- + výsuv Actro, str. 133

Výsuv ACTRO - pre zásuvky ArciTech a bok korpusu 18mm

Menovitá dĺžka (mm)	s tlmením (Silent System)*				push (Push to open)	
	Nosnosť 10kg	Nosnosť 40kg	Nosnosť 60kg	Nosnosť 80kg	Nosnosť 40kg	Nosnosť 60kg
270	809 240 884	809 240 887	-	-	809 150 437	-
300	809 240 885	809 240 888	-	-	809 150 439	-
350	809 240 886	809 240 889	-	-	809 150 441	-
400	-	809 240 890	809 240 896	-	-	809 150 442
450	-	809 240 891	809 240 897	-	-	809 150 443
500	-	809 240 893	809 240 898	809 240 901	-	809 150 445
550	-	809 240 894	809 240 899	809 240 902	-	809 150 446
650	-	809 240 895	809 240 900	809 240 903	-	809 150 447

* uvedené výsuvy je možné použiť na:

1. otváranie pomocou úchytky a zatváranie s tlmením
2. otváranie bez úchytky a zatváranie s tlmením (nutné použiť jednotnotku Push to open Silent)



Push to open silent - pre ArciTech

Menovitá dĺžka (mm)	Celková hmotnosť zásuvky (zaťaženej obvyklým obsahom s čelom z DTD 19mm)			
	< 10kg	8 - 20kg	10 - 40kg	20 - 80kg
270 - 350	809 241 038	-	-	-
270 - 650	-	809 241 049	-	-
270 - 650	-	-	809 241 050	-
400 - 650	-	-	-	809 241 051
ACTRO kg	10	40	40	60/80



Sada obsahuje:

- Push to open Silent, 1 pár
- Aktivátor, 1 pár
- Adaptér pre uchytenie voliteľnej prídavnej synchronizácie, 2 ks

Rozsah hmotnosti pre Push to open Silent

< 10kg	8 - 20kg	10 - 40kg	20 - 80kg

Synchronizácia pre Push to open Silent

- doporučené pre korpus >600mm
- pre ArciTech a InnoTech Atira

Artík. číslo	Názov	Materiál	Povrchová úprava
809 236 718	Synchronizačná tyč 2000mm	hliník	elox. hliník
809 221 295	Spojka	plast	šedá

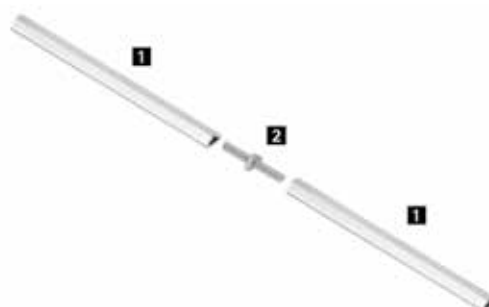

Výsuv QUADRO - pre zásuvky InnoTech/InnoTech Atira a bok korpusu 18mm

Menovitá dĺžka (mm)	s tlmením (Silent System) pre Push To open Silent			s tlmením Silent System*		push (Push to open)	
	Nosnosť 10kg (Quadro V6)	Nosnosť 30kg (Quadro V6)	Nosnosť 50kg (Quadro V6+)	Nosnosť 30kg (Quadro V6)	Nosnosť 50kg (Quadro V6+)	Nosnosť 30kg (Quadro V6)	Nosnosť 50kg (Quadro V6+)
260	809 243 682	809 243 691		800 045 304	-	809 143 517	-
300	809 243 685	809 243 694	809 243 754	809 079 230	809 079 077	809 143 490	809 143 507
350	809 243 688	809 243 697	809 243 757	800 045 305	809 079 079	809 143 491	809 143 508
420		809 243 700	809 243 760	800 045 306	800 048 357	809 143 492	809 143 509
470		809 243 703	809 243 763	800 045 307	800 048 358	809 143 493	809 143 510
520		809 243 706	809 243 766	800 045 308	800 048 359	809 143 494	809 143 435
620	-				800 040 270		809 143 436

* uvedené výsuvy je možné použiť IBA pri otváraní pomocou úchytky a zatváranie s tlmením



Push to open Silent - pre InnoTech

Menovitá dĺžka (mm)	Celková hmotnosť zásuvky (zaťaženej obvyklým obsahom s čelom z DTD 19mm)			
	< 10 kg	8 - 20 kg	10 - 30 kg	20 - 50 kg
260 - 350	809 240 161	-	-	-
260 - 520	-	809 240 162	-	-
260 - 520	-	-	809 240 163	-
300 - 620	-	-	-	809 240 164
QUADRO kg	Quadro V6	Quadro V6	Quadro V6	Quadro V6+



Sada obsahuje:

Push to open Silent, 1 pár

Aktivátor, 1 pár

Adaptér pre uchytanie voliteľnej prídavnej synchronizácie, 2 ks

Rozsah hmotnosti Push to open Silent

< 10 kg	8 - 20 kg	10 - 30 kg	20 - 50 kg
---------	-----------	------------	------------



Zásuvka InnoTech Atira 70mm

Prevedenie

Menovitá dĺžka (mm)	strieborná*	biela*
	zásuvka	zásuvka
260	809 195 081	809 196 129
300	809 195 082	809 196 130
350	809 195 083	809 196 131
420	809 195 084	809 196 132
470	809 195 085	809 196 133
520	809 195 086	809 196 134
620	809 195 087	809 196 135

Zásuvka InnoTech Atira 144 s relingom

Prevedenie

Menovitá dĺžka (mm)	strieborná*		biela*	
	zásuvka	reling	zásuvka	reling
260	809 195 081	809 196 109	809 196 129	809 196 140
300	809 195 082	809 196 110	809 196 130	809 196 141
350	809 195 083	809 196 111	809 196 131	809 196 142
420	809 195 084	809 196 112	809 196 132	809 196 143
470	809 195 085	809 196 113	809 196 133	809 196 144
520	809 195 086	809 196 114	809 196 134	809 196 145
620	809 195 087	809 196 115	809 196 135	809 196 146

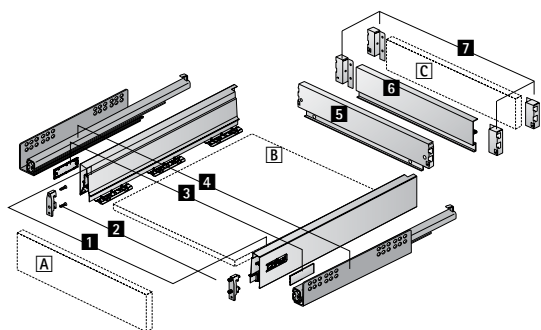

*Sada obsahuje

- 1 Bočnica L+P, 1 pár
- 2 Príchyt čela na zalisovanie, 1 pár
- 3 Krytka plastová s logom Hettich, 2 ks

Nutné objednať:

4 - výsuv Quadro str. 134
7 - sadu držiakov chrbta 70mm (809 195 089 strieborná) alebo (809 916 137 biela)

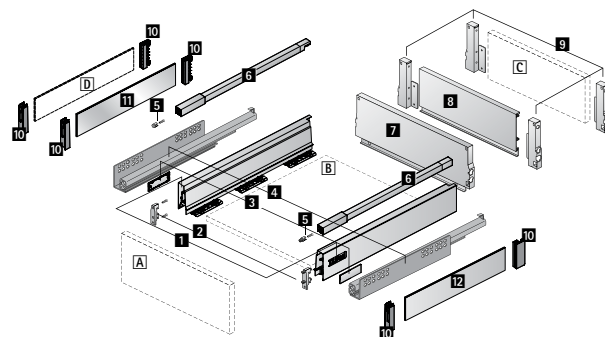

*Sada obsahuje

- 1 Bočnica L+P, 1 pár
- 2 Príchyt čela na zalisovanie, 1 pár
- 3 Krytka plastová s logom Hettich, 2 ks
- 6 pozdĺžny reling L+P, 1 pár
- 5 príchyt relingu na zalisovanie, 2 ks

Nutné objednať:

4 - výsuv Quadro str. 134
9 - sadu držiakov chrbta 144mm (809 196 107 strieborná) alebo (809 196 138 biela)



<https://goo.gl/Y6qf59>



Zásuvka InnoTech Atira 144mm s DesignSide sklo

Prevedenie

Menovitá dĺžka (mm)	strieborná*		biela*	
	zásuvka	DesignSide	zásuvka	DesignSide
260	809 195 081	809 194 797	809 196 129	809 194 804
300	809 195 082	809 194 798	809 196 130	809 194 805
350	809 195 083	809 194 799	809 196 131	809 194 806
420	809 195 084	809 194 800	809 196 132	809 194 807
470	809 195 085	809 194 801	809 196 133	809 194 808
520	809 195 086	809 194 802	809 196 134	809 194 809
620	809 195 087	809 194 803	809 196 135	809 194 810

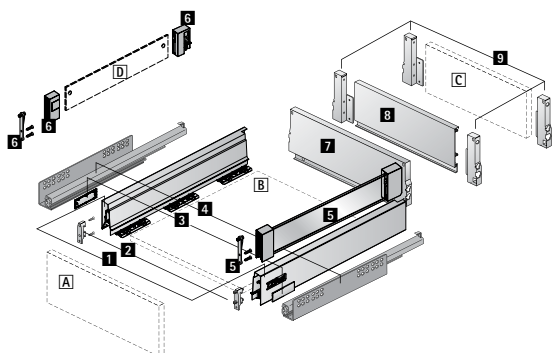

*Sada obsahuje

- 1** Bočnica L+P, 1 pár
- 2** Príchyty čela na zalisovanie, 1 pár
- 3** Krytka plastová s logom Hettich, 2 ks
- 5** DesignSide L+P s adaptérmí, 1 pár
- 6** príchyty čela DesignSide, 2 ks

Nutné objednať:

4 - výsuv Quadro str. 134

9 - sadu držiakov chrbta 144mm (809 196 107 strieborná) alebo (809 196 138 biela)

Zásuvka InnoTech Atira - vnútorná

Prevedenie

Menovitá dĺžka (mm)	strieborná*	biela*	strieborná**	biela*
	čelo pre vnútornú zásuvku 70mm	čelo pre vnútornú zásuvku 70mm	čelo pre vnútornú zásuvku 144mm	čelo pre vnútornú zásuvku 144mm
300	809 194 719	809 194 728	809 194 770	809 194 779
400	809 194 720	809 194 729	809 194 771	809 194 780
450	809 194 721	809 194 730	809 194 772	809 194 781
500	809 194 722	809 194 731	809 194 773	809 194 782
600	809 194 723	809 194 732	809 194 774	809 194 783
800	809 194 724	809 194 733	809 194 775	809 194 784
900	809 194 725	809 194 734	809 194 776	809 194 785
1200	809 194 727	809 194 736	809 194 778	809 194 787

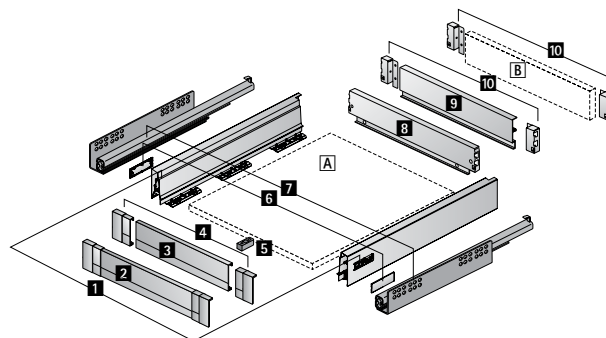

*Sada obsahuje

- 2** čelo pre vnútornú zásuvku bez relingu, 1ks alebo

**Sada obsahuje

- 2** čelo pre vnútornú zásuvku s relingom, 1ks

Nutné objednať:

+ zásuvku InnoTech Atira 70mm alebo 144mm s relingom str., 135 komplet

5 - stabilizátor čela (pre šírku zásuvky >600mm) 809 117 782



Úzka dolná skrinka ArciTech

- výška korpusu max. 750 mm
- šírka korpusu max. 300 mm
- diagonálne osadenie výsuvov ACTRO (P+L)
- celková nosnosť max. 20 kg

Zloženie sady pre zásuvku

- 1 Zásuvka ArciTech 94mm, 1 sada, str. 131
 - 2 Vysoká zásuvka ArciTech 186 mm, 1sada, str. 131
- Výsuv Actro s tlmením Silent System, 1 pár, str. 133

*možnosť aj inej kombinácie

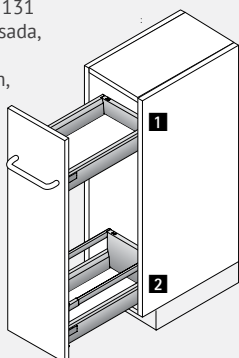

Vysoká skriňa ArciTech

- pre korpusy individuálnej výšky a šírky
- optimálne využitie úložného priestoru
- doporučené šírky korpusu 300 - 600 mm

Zloženie sady pre zásuvku

- 1 Vnútrovná zásuvka ArciTech 94 mm, 1 sada, str. 132
 - 2 Zásuvka ArciTech 186 mm s relingom, 1 sada, str. 131
 - 3 Vnútrovná zásuvka ArciTech 94 mm, 1 sada, str. 132
 - 4 Zásuvka ArciTech 186 mm s relingom, 1 sada, str. 131
- Výsuv Actro s tlmením Silent System, 4 páry, str. 133

*možnosť aj inej kombinácie

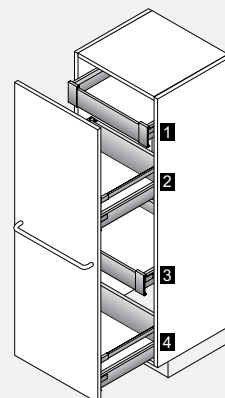

ArciTech (video)
<http://opn.to/a/4a6LD>



Úzka dolná skrinka InnoTech ATIRA

- výška korpusu max. 750 mm
- šírka korpusu max. 300 mm
- diagonálne osadenie výsuvov QUADRO (P+L)
- celková nosnosť max. 20 kg

Zloženie sady pre zásuvku

- 1 Zásuvka InnoTech ATIRA 70mm, 1 sada, str. 135
 - 2 Vysoká zásuvka InnoTech ATIRA 144mm, 1 sada, str. 135
- Výsuv Quadro V6 s tlmením Silent System, 1 pár, str. 134

*možnosť aj inej kombinácie

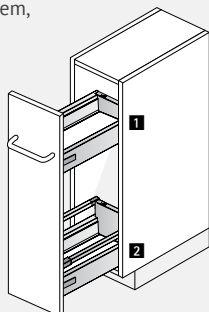

Vysoká skriňa InnoTech ATIRA

- pre korpusy individuálnej výšky a šírky
- optimálne využitie úložného priestoru
- doporučené šírky korpusu 450 - 1200 mm
- doporučený záves s nulovým presahom do svetlosti Sensys 8657i

Zloženie sady pre zásuvku

- 1,2,3 Vnútná zásuvka 100 InnoTech ATIRA 70mm, 1 sada, str. 136
 - 4,5,6 Vnútná vysoká zásuvka 100 InnoTech ATIRA 144mm, 1 sada, str. 136
- Výsuv Quadro V6 s tlmením Silent System, 6 párov, str. 134
- Záves Sensys 8657i, 4 ks, str. 116

*možnosť aj inej kombinácie

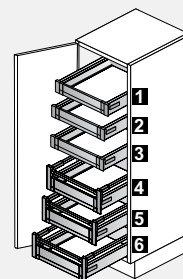

Quadro 4D V6 plnovýsuv, pre hrúbku bokov zásuvky ≤16mm



Quadro 4D V6 (video)



Menovitá dĺžka (mm)	s tlmením (Silent System) pre Push to open Silent**		s tlmením (Silent System)*	push (Push to open)
	Nosnosť 10 kg	Nosnosť 30 kg	Nosnosť 30 kg	Nosnosť 30 kg
250	809 245 377	809 245 382	809 181 288	809 181 303
280	809 245 378	809 245 383	809 181 289	809 181 304
300	809 245 379	809 245 384	809 181 290	809 181 305
320	809 245 380	809 245 385	809 181 291	809 181 306
350	809 245 381	809 245 386	809 181 292	809 181 307
380		809 245 387	809 181 293	809 181 308
400		809 245 388	809 181 294	809 181 309
420		809 245 389	809 181 295	809 181 310
450		809 245 390	809 181 296	809 181 311
480		809 245 391	809 181 297	809 181 312
500		809 245 392	809 181 298	809 181 313
520		809 245 393	809 181 299	809 181 314
550		809 245 394	809 181 300	809 181 315
580		809 245 395	809 181 301	809 181 316
600		809 245 396	809 181 302	809 181 317

* uvedené výsuvy je možné použiť IBA na otváranie pomocou úchytky a zatváranie s tlmením

** k uvedeným výsuvom je potrebné doobjednať spojky a nastavenie sklonu pre drevené zásuvky (art.č. 809 247 529)

uvedené výsuvy je možné použiť AJ BEZ jednotiek Push to open Silent

Push to open Silent - pre Quadro 4D V6

Menovitá dĺžka (mm)	Celková hmotnosť zásuvky (zťaženaj obvyklým obsahom s čelom z DTD 19mm)		
	< 10 kg	8 - 20 kg	10 - 30 kg
260 - 350	809 246 312	-	-
260 - 520	-	809 244 315	-
260 - 520	-	-	809 246 316
300 - 600	-	-	-
QUADRO kg	Quadro 4D V6	Quadro 4D V6	Quadro 4D V6

Rozsah hmotnosti Push to open Silent

< 10 kg	8 - 20 kg	10 - 30 kg
---------	-----------	------------



Sada obsahuje:

jednotka Push to open Silent, 1 pár

aktivátor, 1 pár

adaptér pre uchytenie voliteľnej prídavnej synchronizácie, 2 ks

Synchronizácia pre Push to open Silent

- doporučené pre korpus >600mm

- pre výsuv Quadro 4D

Artik. číslo	Názov	Materiál	Povrchová úprava
809 236 718	Synchronizačná tyč 2000mm	hliník	elox. hliník
809 221 295	Spojka	plast	šedá





spojky

Quadro V6 plnovýsuv, pre hrúbku bokov zásuvky ≤16mm

Menovitá dĺžka (mm)	s tlmením (Silent System)*		push (Push to open)*	
	pravý	ľavý	pravý	ľavý
250	809 135 983		809 135 984	
280	800 045 284		-	
300	800 045 285		809 135 985	
320	800 045 286		809 135 986	
350	800 045 287		809 135 987	
380	800 045 288		809 135 988	
400	800 045 289		809 135 989	
420	800 045 290		809 135 990	
450	800 045 291		809 135 991	
480	800 045 292		809 135 992	
500	800 045 293		809 135 993	
520	800 045 294		809 135 994	
550	800 045 295		809 135 995	
580	800 045 296		809 212 281	
600	800 045 297		809 212 285	

Quadro V6 plnovýsuv, pre hrúbku bokov zásuvky až ≤19mm

Menovitá dĺžka (mm)	s tlmením (Silent System)*		push (Push to open)*	
	pravý	ľavý	pravý	ľavý
300	809 225 673	809 225 674	809 225 734	809 225 735
350	809 225 675	809 225 676	809 225 737	809 225 738
400	809 225 677	809 225 678	809 225 739	809 225 740
450	809 225 729	809 225 730	809 225 741	809 225 742
500	809 225 731	809 225 732	809 225 743	809 225 744

* k uvedeným výsuvom je potrebné doobjednať spojky pre drevené zásuvky (art.č. 809 9144 597)



bez tlmenia



Výsuvy pre drevené zásuvky



s tlmením

Guličkové plnovýsuvy

Menovitá dĺžka (mm)	bez tlmenia	s tlmením				s otváraním
	montáž na bok	montáž na bok so samostatváračím	montáž na bok	montáž na bok	montáž na dno	montáž na bok
		Hettich KA 5632 SC	Hettich KA 4532 SiSy			Hettich KA 4532 P20
250	1662250					
300	1662300	809 180 090	809 114 271	1662301		809 114 281
350	1662350	809 180 131	809 114 273	1662351		809 114 282
400	1662400	809 180 132	809 114 274	1662401	1600105	809 114 283
450	1662450	809 180 133	809 114 275	1662451	1600205	809 114 284
500	1662500	809 180 134	809 114 276	1662501	1600305	809 114 285
550	1662550	809 180 135	809 114 277	1662551		809 114 286
600	1662600	809 180 136	809 114 278	1662601		809 114 288
700	1662700					
800			809 114 280	1662801		809 114 290



Guličkový čiastočný výsuv 17 mm

Menovitá dĺžka (mm)	Prevedenie	
	pozink	
180	16 61 1 80	
215	16 61 2 15	
240	16 61 2 40	
280	16 61 2 80	
310	16 61 3 10	
340	16 61 3 40	
400	16 61 4 00	
450	16 61 4 50	



Kolieskový čiastočný výsuv

Menovitá dĺžka (mm)	Prevedenie	
	biela	čierna
250	16 25 7 82	16 30 7 83
300	16 30 7 82	
350	16 35 7 82	16 35 7 83
400	16 40 7 82	
450	16 45 7 82	16 45 7 83
500	16 50 7 82	
550	16 55 7 82	16 55 8 91
600		16 60 7 83



Zásuvka Metal Box

Menovitá dĺžka v mm	Prevedenie - biela			
	56 mm	86 mm	118 mm	150 mm
270		16 92 8 27		
300		16 92 8 30		16 93 8 30
350		16 92 8 35		
400		16 92 8 40		
450		16 92 8 45	16 00 7 51	16 93 8 45
500	16 92 8 05	16 92 8 50		16 93 8 50
550		16 92 8 55		
650				



Titusoft WD

- určené pre dodatočné tlmenie kolieskových výsuvov

Typ	Obj. číslo	Balenie
Tlmič Titusoft WD	16 00 0 08	1 sada



Západka stlačná

Západka stlačná (video)

- vytvorenie PUSH systému pre závesy a výsuvy bez tlmenia

Typ	Obj. číslo	Balenie
Západka s priamym uchytením	16 00 0 82	1 ks
Západka s priečnym uchytením	16 00 0 75	1 ks



Príbormík OrgaTray 440

Šírka korpusu (v mm)	Upraviteľná šírka príborníka (mm)	Plast strieborný	Plast biely
275	175-200	809 194 930	809 194 961
300	201-250	809 194 931	809 194 962
350	251-300	809 194 932	809 194 963
400	301-350	809 194 933	809 194 964
450	351-400	809 194 934	809 194 965
500	401-450	809 194 935	809 194 966
550	451-500	809 194 936	809 194 967
600	501-600	809 194 937	809 194 968
700	601-700	809 194 938	809 194 969
800	701-800	809 194 939	809 194 970
900	801-900	809 194 940	809 194 971
1000	901-1000	809 194 941	809 194 972
1200	1091-1150	809 194 942	809 194 973



Príbormík OrgaTray 590

Šírka korpusu (v mm)	Upraviteľná šírka príborníka (mm)	Plast strieborný	Plast biely
300	207x462	809 194 886	809 194 897
400	307x462	809 194 887	809 194 898
450	357x462	809 194 888	809 194 899
500	407x462	809 194 889	809 194 900
550	457x550	809 194 890	809 194 901
600	507x462	809 194 891	809 194 902
800	707x462	809 194 892	809 194 903
900	807x462	809 194 893	809 194 904
1000	907x462	809 194 894	809 194 905



Deliace prvky pre OrgaTray 590

Šírka prvku (mm)	Plast strieborný	Plast biely
68	809 204 229	809 204 230
128	809 005 931	809 204 201



Príbormík OrgaTray 500

Šírka korpusu (v mm)	Upraviteľná šírka príborníka (mm)	Plast strieborný	Plast biely
300	201-250	809 044 933	-
400	301-350	809 044 932	-
450	351-400	809 044 931	-
500	401-450	809 044 929	-
600	501-550	809 044 928	-



Protišmyková podložka

Šírka podložky (mm)	Farba šedá
480	16 00 2 80



Systema Top 2000 prinesie poriadok do každého kancelárskeho kontajnera. Praktický modulový systém ponúka množstvo funkčných prvkov, farieb, veľkostí a výbavy. Sortiment Systema Top 2000 je štandardom pre moderné usporiadanie kontajnera. Teraz ho Hettich vo všetkých smeroch ešte vylepšil. Všetko ľahko po ruke vďaka skúsenostiam popredného poskytovateľa systémov. Pomocou rozsiahleho stavebnicového systému sa dá splniť každá individuálna požiadavka na kancelársky nábytok.



Deliace priečky, prepážky a OrgaWelle prinesú poriadok do každej zásuvky.



Zásuvka na písacie potreby: každá ceruzka v pohodlnom dosahu.



Rfektívne využitie úložného priestoru a pekný design na pracovisku: to je DesignSide zo skla.



Rýchlo nájdete každý dokument: so stabilným rámom na závesné zložky je to jednoduché.



OrgaTank usporiada dokumenty aj osobné veci



Dokonale usporiadané do najmenšieho detailu: Systema Top 2000 je individuálna rovnako ako Vaše požiadavky



Plnovýsuv s presahom pre pohodlný prístup ku kompletnému obsahu zásuvky.



Push to open pre otváranie zásuviek bez úchytiak.



Systema Top 2000 (video)

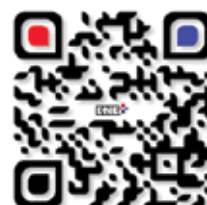

Kancelárske systémy



POSUVNÉ SYSTÉMY
SLIDING SYSTEMS

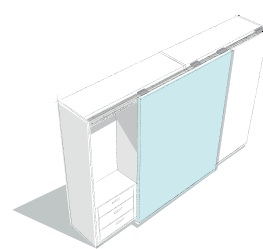
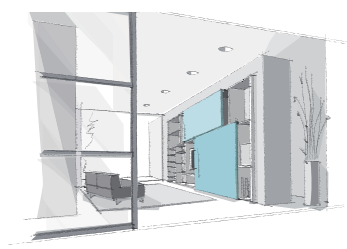
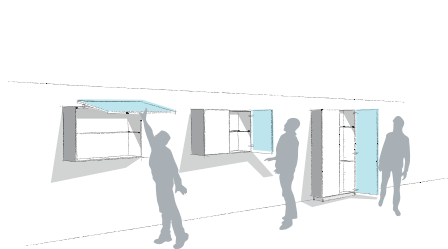

Ergonómia

Výhody posuvných dverí

Silné stránky posuvných dverí sa prejavia pri každodennom používaní. Posuvné dvere vzhľadom k ergonómii a komfortu stoja za uváženie.

A to z dobrých dôvodov:

- otvorené posuvné dvere neprekážajú v úzkych priechodoch medzi nábytkom
- u horných skriniek nehrozí kvôli otvoreným dverám nebezpečenstvo úrazu.

Okrem toho sa dajú posuvné dvere pohodlne obsluhovať bez predkláňania alebo stúpania na špičky.

Design

Tvorba interiéru s posuvnými dverami

Pomocou posuvných dverí je možné zrealizovať modernú, veľkorysú architektúru aj v nábytku. Veľkoplošné dvere umožňujú puristické navrhovanie interiéru. Výhodou moderných systémov pre posuvné dvere sú úzke medzery, ktoré sú navyše vďaka veľkým formátom zredukované na minimum. Komfortné a presné nastavenie zaručuje bezchybný výsledok montáže.

Funkčnosť

Čo musia viesť dobré nábytkové dvere

Pre väčšinu spotrebiteľov sú dôležité funkčné aspekty, najmä pohodlné otváranie a zatváranie.

Výhoda lineárneho pohybu posuvných dverí by mala byť spojená s malou silou, ktorú treba vynaložiť na otvorenie dverí. Veľmi pozitívne je hodnotený taktiež komfort mäkkého a tichého zatvárania s tlmením.

Od perfektného systému posuvných dverí sa ďalej očakáva ľahký chod, spoľahlivosť a dlhá životnosť.

Technik für Möbel



InLine XL

TopLine XL

TopLine L

TopLine M

SlideLine M

WingLine L



Strana	146	147	148	149	150	151
Popis	kovanie pre posuvné dvere s horným nosným vedením pre veľké skrine	kovanie pre posuvné dvere s horným nosným vedením pre veľké skrine	kovanie pre posuvné dvere s horným nosným vedením	kovanie pre posuvné dvere s horným nosným vedením	kovanie pre posuvné dvere s dolným nosným vedením	kovanie pre skladané dvere spojené s bokom, s horným nosným profilom a dolným vodiacim profilom
Počet dverí/krídel*	2	1-4	1-4	1-3	1-2	2 krídla*
Hmotnosť dverí/krídla* max.	60 kg	80 kg	50 kg	35 kg	30 kg	25 kg*
Výška dverí/krídla* max.	2600 mm	2600 mm	2600 mm	2300 mm	2000 mm	2400 mm * 2600 mm **
Šírka dverí/krídla*	750 - 2000 mm	700 - 2000 mm	700 - 1500 mm	500 - 1250 mm	300 - 1800 mm	max. 600 mm*
Hrúbka dverí/krídla*	16 - 25 mm	16, 18, 19, 22, 25, 28, 40, 50 mm	16, 18, 19, 22, 25, 40 mm	16 - 19 mm	15, 16, 18, 19, 22, 25, 38 mm	16 - 25 mm
Tlmenie Silent System	v smere zatvárania a otvárania	v smere zatvárania a otvárania, kolízne tlmenie, dolné tlmenie	v smere zatvárania a otvárania, dolné tlmenie	v smere zatvárania	v smere zatvárania a otvárania, protikolízne tlmenie	v smere otvárania a zatvárania v závislosti od typu mechanizmu

** pri dodržaní hmotnosti krídla a znížení umiestnenia aktivátora s magnetom

InLine XL



- bez rušivých odskokov, sotva viditeľné medzery, fascinujúca veľká plocha
- dvere v jednej rovine môžete pohodlne otvoriť aj bez úchytiak
- pohodlné a presné nastavenie zaručuje bezchybnú montáž s perfektnými medzerami
- maximálne využitie úložného priestoru vďaka otvoreniu dverí bez ich presahu do svetlosti
- rýchla a hospodárna montáž vďaka predmotosvaným celkom
- ani pre veľké dvere nič zložité

Sada na 1 skriňu s 2 dverami so Silent System obsahuje:

- 1 ks nosný profil s 2-mi predmotosvanými nosnými vozíkmi
- 1 ks vodiaci profil
- 2 ks vozík L + P
- 2 ks oblúkový diel pre vodiaci profil
- 1 ks tlmiaca jednotka Silent System
- 4 ks držiak dverí horný, 2x L + 2x P
- 4 ks držiak dverí dolný
- 2 ks hliníkový krycí profil
- 2 ks plastový krycí profil
- Upevňovací materiál

Šírka 1 krídla (v mm)	Max. výška dverí (v mm)	Artik. číslo	Balenie
750 - 819	< 2000	809 148 180	1 sada
820 - 909	< 2000	809 148 201	1 sada
910 - 1044	< 2200	809 148 202	1 sada
1045 - 1199	< 2200	809 148 203	1 sada
1200 - 1299	< 2400	809 148 204	1 sada
1300 - 1499	< 2400	809 148 205	1 sada
1500 - 1599	< 2600	809 148 206	1 sada
1600 - 1799	< 2600	809 116 581	1 sada
1800 - 1899	< 2600	809 155 574	1 sada
1900 - 2000	< 2600	809 155 575	1 sada

Doplňková sada montážnych prvkov

- voliteľná doplnková sada montážnych prvkov
- slúži na skryté uchytenie profilov do korpusu pri skrini vysokej až po strop

Šírka 1 krídla (TB) v mm	Artik. číslo	Balenie
750 - 2000	809 148 562	1 sada

Prípustné formáty dverí

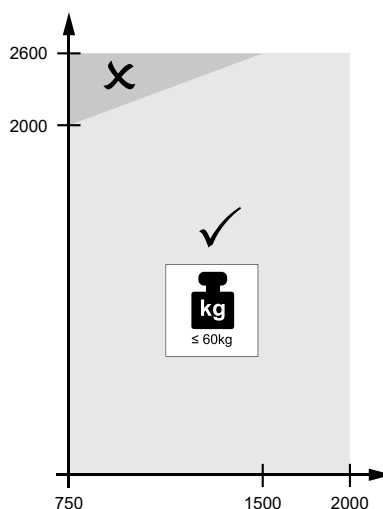

Vyrovnávacie kovanie plastové

- k vyrovnaniu deformovaných nábytkových dverí
- možné použiť aj preventívne proti prehnutiu dverí
- pre hrúbky dverí 16 - 25 mm
- doporučujeme použiť na každé dvere 2 sady

Obj. číslo	Balenie
800 045 198	1 sada

Pre bližšie informácie naskenujte



www.hettich.com/short/e5ec09

TopLine XL



- pomocou Silent System sa ľahko otvorí a mätko zatvorí
- rychlomontáž dverí, tlmenia a profilov znižuje náročnosť montáže a šetrí čas- jednoduchá montáž
- maximálne využitie úložného priestoru vďaka otvoreniu dverí bez ich presahu do svetlosti
- zvládne aj veľkoformátové dvere do 80 kg

Sady kovania pre 2 dvere (nutné kombinovať s tlmením Silent System)

Max. hrúbka dverí (v mm)	2 dvere		
	Predné dvere VPRAVO	+	Zadné dvere VĽAVO
16, 18 resp. 19	809 181 742	+	809 181 744
22	809 183 613	+	809 181 744
28	809 183 615	+	809 181 744
30, 32 resp. 33	809 193 053	+	809 181 744
40	809 183 616	+	809 181 744
50	809 183 617	+	809 181 744
Sada Silent System v smere zatvárania a otvárania	809 169 548		

Prípustné formáty dverí

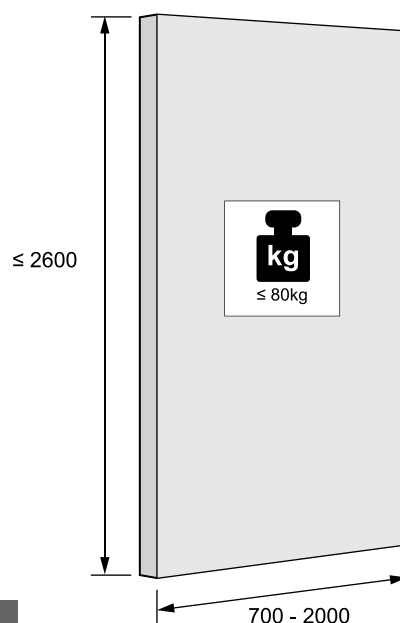

Sady kovania pre 3 dvere (nutné kombinovať s tlmením Silent System)

Max. hrúbka dverí (v mm)	3 dvere				
	Zadné dvere VĽAVO	+	Predné dvere V STREDE	+	Zadné dvere VPRAVO
16, 18 resp. 19	809 181 744	+	809 181 742	+	809 183 533
22	809 181 744	+	809 183 613	+	809 183 533
28	809 181 744	+	809 183 615	+	809 183 533
30, 32 resp. 33	809 181 744	+	809 193 053	+	809 183 533
40	809 181 744	+	809 183 616	+	809 183 533
50	809 181 744	+	809 183 617	+	809 183 533
Sada Silent System v smere zatvárania a otvárania	809 154 933				

Sada profilov LA 10407 (hliník)

Položka	Artik. číslo
3000	809 191 082
4000	809 191 083
6000	809 191 108

Pre bližšie informácie naskenujte



www.hettich.com/short/fa9225

TopLine L



- pomocou Silent System sa ľahko otvorí a mätko zatvorí
- komfortná montáž
- jednoduchá montáž
- dvere bez úchytiiek sa otvoria do plného zákrytu bez predsadenia
- pohodlné nastavenie výšky zavesených dverí

Sady kovania pre 2 dvere (nutné kombinovať s tlmením Silent System)

Max. hrúbka dverí (v mm)	2 dvere		
	Predné dvere VPRAVO	+	Zadné dvere VĽAVO
16	80 926 483	+	809 206 507
19	809 206 500	+	809 206 507
22	809 206 501	+	809 206 507
25	809 206 502	+	809 206 507
40	809 206 503	+	809 206 507
Sada Silent System v smere ZATVÁRANIA	809 182 589		
Sada Silent System v smere OTVÁRANIA	809 182 572		

Sady kovania pre 3 dvere (nutné kombinovať s tlmením Silent System)

Max. hrúbka dverí (v mm)	3 dvere				
	Zadné dvere VĽAVO	+	Predné dvere V STREDE	+	Zadné dvere VPRAVO
16, 18 resp. 19	809 206 507	+	809 206 483	+	809 206 507
22	809 206 507	+	809 206 500	+	809 206 507
28	809 206 507	+	809 206 501	+	809 206 507
30, 32 resp. 33	809 206 507	+	809 206 502	+	809 206 507
40	809 206 507	+	809 206 503	+	809 206 507
Sada Silent System v smere ZATVÁRANIA	809 182 574				
Sada Silent System v smere OTVÁRANIA	809 182 573				

Sada profilov (hliník)

Položka	Artik. číslo
3000	809 184 801
4000	809 184 809
6000	809 212 275

Prípustné formáty dverí

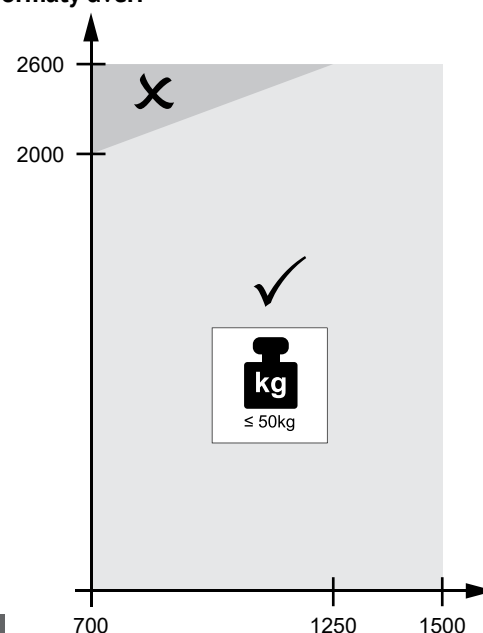

Pre bližšie informácie naskenujte



www.hettich.com/short/8fa9a0

TopLine M



- pomocou Silent System sa ľahko otvorí a ticho zatvorí
- ľahká výmena otváracích dverí za posuvné
- dvere so zapustenými úchytkami sa otvoria do plného zákrytu bez predsadenia
- dolný profil je možné namontovať voliteľne POD alebo PRED dno korpusu

Pre bližšie informácie naskenujte



www.hettich.com/short/8260f3

Sady kovania pre 2 dvere (nutné kombinovať s tlmením Silent System)

Max. hrúbka dverí (v mm)	2 dvere	
	dolné vedenie PRED dnom	dolné vedenie POD dnom
19	809 133 612	809 133 641
Sada Silent System v smere ZATVÁRANIA	809 144 901	

Sady kovania pre 3 dvere (nutné kombinovať s tlmením Silent System)

Max. hrúbka dverí (v mm)	3 dvere	
	dolné vedenie PRED dnom	dolné vedenie POD dnom
19	809 129 577	809 133 642
Sada Silent System v smere ZATVÁRANIA	809 144 902	

Prípustné formáty dverí

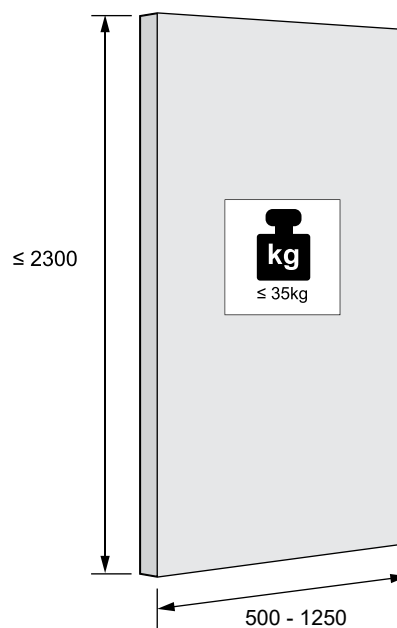

Nosný profil

Dĺžka (v mm)	Hliník	Oceľ
2100	809 131 817	809 138 053
2500	809 131 818	809 138 054
3000	809 131 819	809 138 055

Vodiaci profil (plast)

Dĺžka (v mm)	pre dolné vedenie PRED dnom	pre dolné vedenie POD dnom
2100	809 131 834	809 131 831
2500	809 131 836	809 131 832
3000	809 131 837	809 131 833

SlideLine M



- Silent System umožňuje ľadné a tiché otváranie a zatváranie
- vhodné pre drevené, sklenené alebo dvere s hliníkovým rámom
- jednoduchá montáž
- určené pre obývacie steny a policové systémy, horné kuchynské skrinky, taktiež kúpeľňový či kancelársky nábytok
- pohodlná a rýchla montáž
- možnosť naložených alebo vložených dverí

Sada kovania

- sada kovania so Silent System (tlmenie v smere zatvárania, otvárania a kolízie)
- pre drevené dvere a dvere s hliníkovým rámom 55 mm*

Max. hmotnosť dverí (v kg)	Minimálna šírka dverí (v mm)	
10	450	809 201 921
30	450	809 156 338

Sada kovania

- sada kovania bez Silent System
- pre drevené dvere a dvere s hliníkovým rámom 55 mm*

Max. hmotnosť dverí (v kg)	Minimálna šírka dverí (v mm)	
10	300	809 156 339

Vodiaci profil

- pre naložené dvere

Dĺžka (v mm)	Pre hrúbku materiálu (v mm)	Obj. číslo
2500	15, 16	809 209 223
2500	18, 19	809 209 225
2500	22	809 209 228
2500	25	809 209 230

Vodiaci profil

- pre vložené dvere

Dĺžka (v mm)	2-dráhový profil na prilepenie	2-dráhový profil na priskrutkovanie	1-dráhový profil na zalisovanie
2500	809 227 186	809 227 183	809 227 188

Prípustné formáty dverí

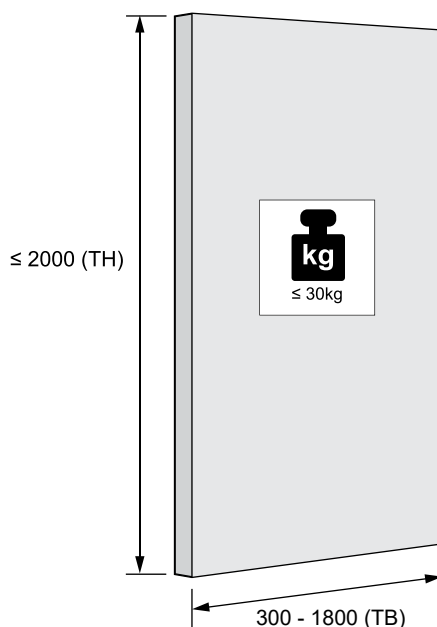

$$TH = (\leq 2 \times TB)$$

Pre bližšie informácie naskenujte



<https://goo.gl/B4i3Mx>

* pre sklenené dvere a dvere s hliníkovým rámom 19 mm, je potrebné objednať sadu príslušných adaptérov

WingLine L



- dokonalý prehľad a prístup až k 6m² plochy skrine

- prvotriedny užívateľský komfort

- optimálne využitie priestoru s minimálnym presahom iba 45mm

- kompletne otvorenie jedným stlačením dverí vďaka Push to move

- pohodlná a rýchla montáž

- efektívnu montáž zvládne jeden človek vďaka inteligentnému príslušenstvu

Pre bližšie informácie naskenujte



<https://goo.gl/BYNNhe>

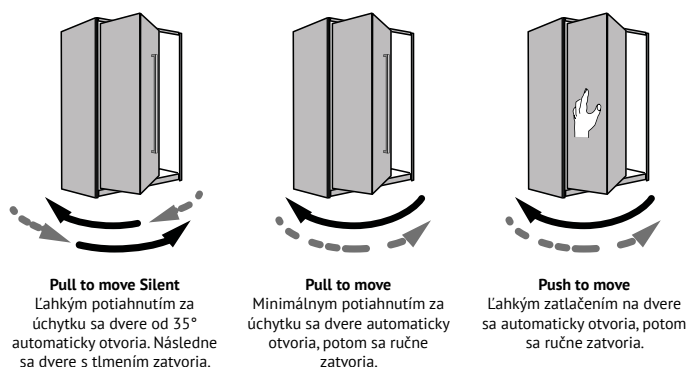

Pull to move Silent
Lahkým potiahnutím za úchytka sa dvere od 35° automaticky otvoria. Následne sa dvere s tlmením zatvoria.

Pull to move
Minimálnym potiahnutím za úchytka sa dvere automaticky otvoria, potom sa ručne zatvoria.

Push to move
Lahkým zatlačením na dvere sa automaticky otvoria, potom sa ručne zatvoria.

Profily

Dĺžka (v mm)	Nosný profil	Vodiaci profil
1200	809 237 916	809 237 989
2400	809 237 917	809 237 990

Sada kovania (nutné kombinovať s tlmiacim mechanizmom)

- pre 1 skládané dvere s 2 krídlami

Hmotnosť krídla max. (v kg)	Spodné vedenie	Pull to move Silent		Pull to move		Push to move	
		L'AVÉ	PRAVÉ	L'AVÉ	PRAVÉ	L'AVÉ	PRAVÉ
25	ÁNO	809 237 852	809 237 890	809 237 880	809 237 881	809 237 880	809 237 881
12	ÁNO	809 237 882	809 237 906	809 237 905	809 237 904	809 237 905	809 237 904
12 bez dolného vedenia	NIE	809 237 903	809 237 902	809 237 901	809 237 900	809 237 901	809 237 900
*doporučené závesy		Sensys 8645i str. 114		Sensys 8675 str. 114		Sensys 8675 str. 114	

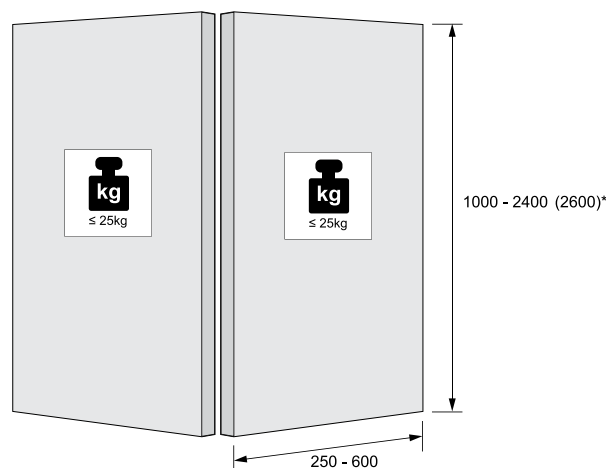

* pri dodržaní hmotnosti krídla a znížení umiestnenia aktivátora s magnetom

Tlmiaci mechanizmus

- pre 1 skládané dvere s 2 krídlami

Výkonnosť trieda	Pull to move Silent		Pull to move		Push to move	
	L'AVÉ	PRAVÉ	L'AVÉ	PRAVÉ	L'AVÉ	PRAVÉ
ľahká	809 238 120	809 238 119	809 238 117	809 238 118	809 238 102	809 238 113
stredná	809 238 121	809 238 124	809 238 115	809 238 116	809 238 051	809 238 101
ťažká	809 238 123	809 238 122	809 238 125	80 923 114	809 238 052	809 238 053

KOVANIE SEVROLL - 18



DTD/sklo *

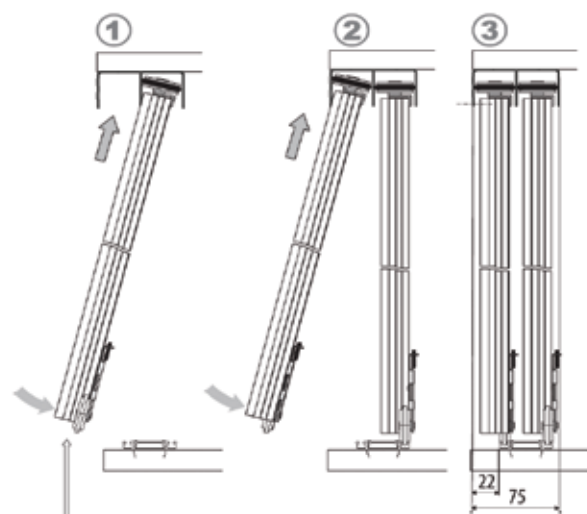

Otvory vyvrtané vrtakom $\varnothing 3$ mm je treba dodatočne frézovať z vnútornej strany vedenia, vrtakom $\varnothing 7$ mm.

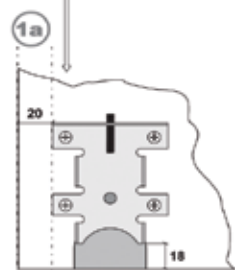

K: L

POZOR: pri montáži pevných častí je veľmi dôležité, aby osa K bola rovnobežná s osou L (KIIL)

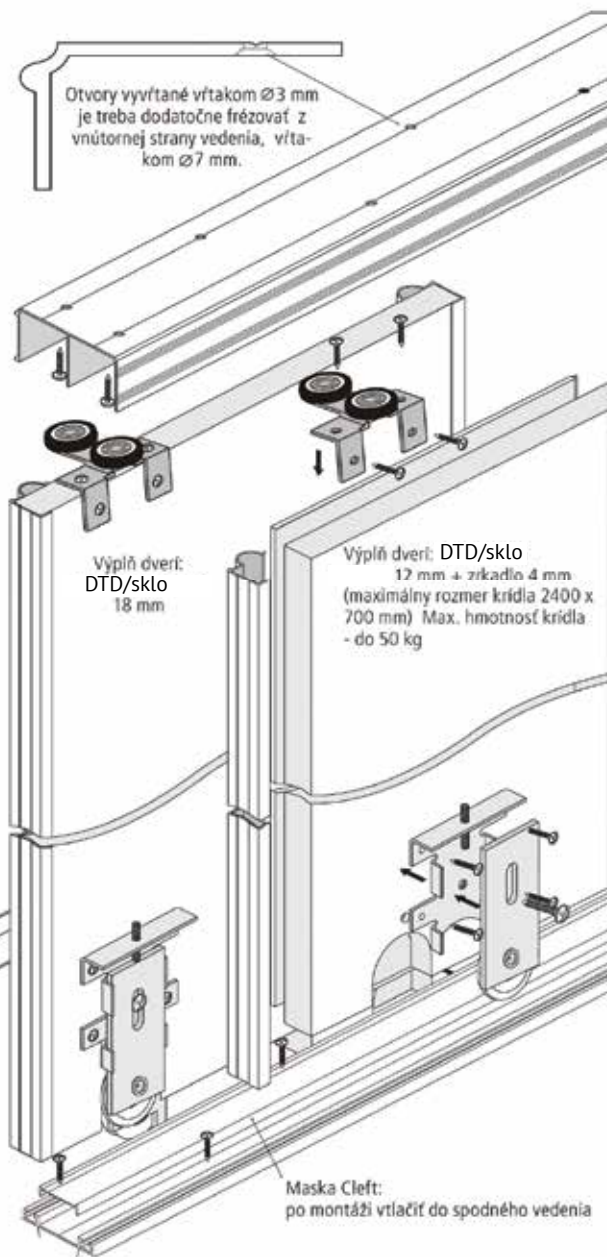
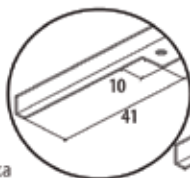
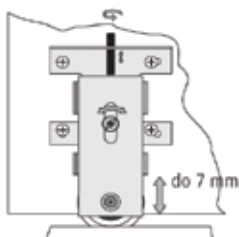

MADLO ALFA 18



MADLO ERGO 18



MADLO FOCUS 18



Dĺžka v mm	Artik. číslo	Povrch. úprava	Balenie
2700	16 00 2 08	Crn	1 ks

Dĺžka v mm	Artik. číslo	Povrch. úprava	Balenie
2700	16 00 1 73	Crn	1 ks

Dĺžka v mm	Artik. číslo	Povrch. úprava	Balenie
2700	16 00 0 09	Crn	1 ks

* Používajte bezpečnostné sklo alebo zrkadlo. Prípadne zabezpečte potrebnou fóliou.

Vozíky

- na každé dvere je potrebné použiť sadu vozíkov t.j. 2ks

Typ vozíka	Artik. číslo	Balenie
Horný vozík s ložiskom	16 00 0 19	sada
Spodný vozík s ložiskom	16 00 0 18	sada

Tlmenie

- na každé dvere je potrebné použiť 1ks tlmenia a horný vozík 1ks
- v sade 2ks

Tlmenie	Artik. číslo	Balenie
Tlmenie pre dvere 25 - 50 kg	16 00 0 48	sada

Protiprachové štetiny

Štetina (v mm)	Artik. číslo	Balenie
Dorazová 4,8 x 4 - samolepiaca	16 00 0 24	bm
Dorazová 4,8 x 4 - nasúvacia	16 00 0 44	bm
Dorazová 6,7 x 4 - samolepiaca	16 00 0 57	bm
Medzidverová 6,7 x 12 - samolepiaca	16 00 0 25	bm

Vodiace profily

- v povrchovej úprave Crm

Dĺžka (v mm)	Horný	Spodný
1700	16 00 0 11	16 00 0 15
2350	16 00 0 13	16 00 0 16
3000	16 00 0 26	16 00 0 27
4050	16 00 0 14	16 00 0 17

Ostatné profily

- v povrchovej úprave Crm

Dĺžka (v mm)	Krycí profil "Maska Cleft"	Uholník Mini	Spojovací profil "H"	Spojovací profil "T"
1700	16 00 0 54	16 00 0 21	-	-
2350	16 00 0 55	16 00 0 33	-	-
3000	16 00 0 56	16 00 0 22	16 00 0 23	16 00 6 81
4050	16 00 0 47	-	-	-

KOVANIE UNIPOS



Typ	Obj. číslo				Balenie
	biela	béžová	hnedá	čierna	
Profil 1200 mm	16 17 0 10	16 17 0 30	16 17 0 20	16 17 0 90	1 ks
Spodné vedenie	16 17 0 12	16 17 0 32	16 17 0 22	16 17 0 92	1 ks
Horné vedenie	16 17 0 11	16 17 0 31	16 17 0 21	16 17 0 91	1 ks

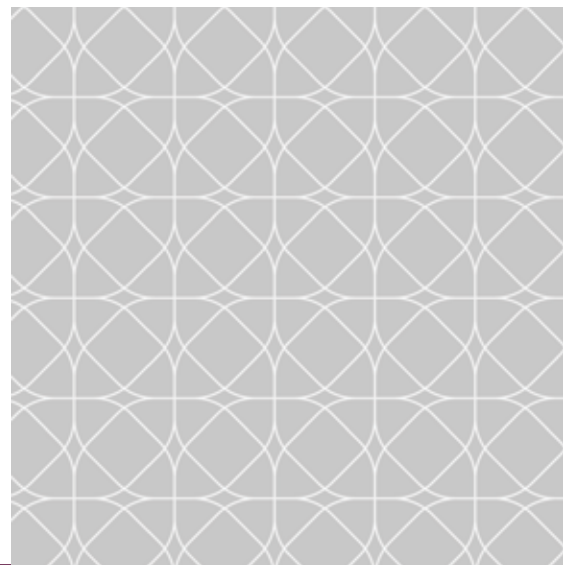
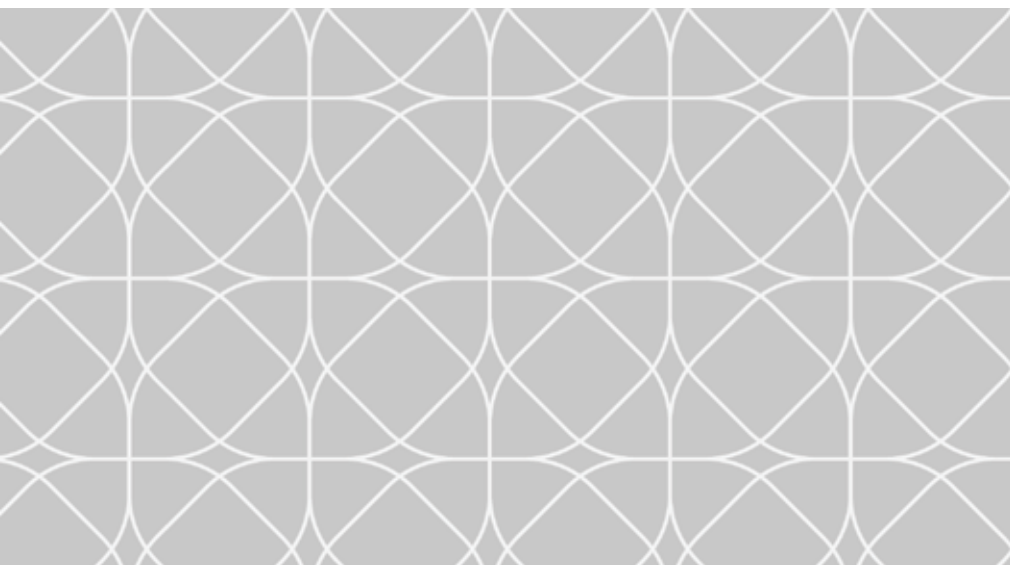

*DRÔTENÝ PROGRAM
KITCHEN PARTS*

VÝSUVNÝ KŮŠ guličkový plnovýsuv



Artik. číslo	Název	Materiál	Povrch. úprava	105	450	550
19 00 0 12	VÝSUVNÝ KŮŠ	S	Cr			

VÝSUVNÝ KŮŠ - výsuv Quadro Hettich



Artik. číslo	Název	Materiál	Povrch. úprava	110	270	550
19 00 3 02	VÝSUVNÝ KŮŠ BOČNÝ 150	S	Cr	110	270	550
19 00 4 02	VÝSUVNÝ KŮŠ BOČNÝ 150	S	Cr	110	425	525
19 00 0 33	VÝSUVNÝ KŮŠ BOČNÝ 150 - plné dno	S	Cr	110	425	525
19 00 4 62	VÝSUVNÝ KŮŠ BOČNÝ 200	S	Cr	168	425	525
19 00 0 23	ODDELOVAČ PŘE KŮŠ 150					

VÝSUVNÝ KŮŠ - výsuv Quadro Hettich



Artik. číslo	Název	Materiál	Povrch. úprava	260/268	425	525
19 00 0 13	VÝSUVNÝ KŮŠ 30	S	Cr	260/268	425	525
19 00 0 14	VÝSUVNÝ KŮŠ 40	S	Cr	360/368	425	525
19 00 0 15	VÝSUVNÝ KŮŠ 45	S	Cr	410/418	425	525
19 00 0 16	VÝSUVNÝ KŮŠ 50	S	Cr	460/468	425	525
19 00 0 17	VÝSUVNÝ KŮŠ 60	S	Cr	560/568	425	525

CARGO MAXI



Artik. číslo	Název	Materiál	Povrch. úprava	500	300	1710-1910
-	CARGO MAXI 5-policový 30	S	Cr	500	300	1710-1910
-	CARGO MAXI 5-policový 40	S	Cr	500	400	1710-1910
-	CARGO MAXI 5-policový 50	S	Cr	500	500	1710-1910
-	CARGO MAXI 5-policový 60	S	Cr	500	600	1710-1910
-	CARGO MAXI 6-policový 30	S	Cr	500	300	1910-2110
-	CARGO MAXI 6-policový 40	S	Cr	500	400	1910-2110
-	CARGO MAXI 6-policový 50	S	Cr	500	500	1910-2110
-	CARGO MAXI 6-policový 60	S	Cr	500	600	1910-2110

OTOČNÝ KŮŠ



Artik. číslo	Název	Materiál	Povrch. úprava	∅	635-850
19 10 3 34	OTOČNÝ KŮŠ 3/4, ∅ 600	S	C, Cr	595	635-850
19 10 3 36	OTOČNÝ KŮŠ 3/4, ∅ 750	S	C, Cr	745	635-850
19 00 0 28	OTOČNÝ KŮŠ 1/2, ∅ 750	S	C, Cr	745	635-850
19 10 3 3x	OTOČNÝ KŮŠ 1/2, ∅ 820	S	C, Cr	815	635-850

KŮŠ NA TOPÁNKY



Artik. číslo	Název	Materiál	Povrch. úprava	555	252	335
19 10 8 03	KŮŠ NA TOPÁNKY	S	C	555	252	335

MAGIC CORNER



Artik. číslo	Názov	Materiál	Povrch. úprava	mm	mm	mm
19 10 3 0x	VÝSUVNÝ KÔŠ MAGIC CORNER 800	S	Cr	660	500	570
19 10 3 0x	VÝSUVNÝ KÔŠ MAGIC CORNER 1000	S	Cr	710	500	570
19 10 3 0x	VÝSUVNÝ KÔŠ MAGIC CORNER 1200	S	Cr	920	500	570

KÔŠ NA BIELIZEŇ



Artik. číslo	Názov	Materiál	Povrch. úprava	mm	mm	mm
19 00 0 51	KÔŠ NA BIELIZEŇ 30	S	Cr	255	255	600
19 00 1 51	KÔŠ NA BIELIZEŇ 40	S	Cr	255	335	600
19 00 2 51	KÔŠ NA BIELIZEŇ 50	S	Cr	255	435	600

ODKVAPKÁVAČ DO SKRINKY 900



Artik. číslo	Názov	Materiál	Povrch. úprava	mm	mm
19 13 3 00	ODKVAPKÁVAČ DO SKRINKY 900	Al,S,P	Cr,Crm	866	290

ODKVAPKÁVAČ DO SKRINKY 600



Artik. číslo	Názov	Materiál	Povrch. úprava	mm	mm
19 13 3 02	ODKVAPKÁVAČ DO SKRINKY 600	x	x	565	290

KONZOLA BAROVÉHO PULTU



Artik. číslo	Názov	Materiál	Povrch. úprava	mm
89 00 1 4x	KONZOLA BAROVÉHO PULTU KOLMÁ	S	Cr,Crm,li	200

KONZOLA BAROVÉHO PULTU



Artik. číslo	Názov	Materiál	Povrch. úprava	mm	mm
89 00 x 0x	KONZOLA BAROVÉHO PULTU ŠIKMÁ	S	Cr,Crm,Nim	50	250
89 00 x 0x	KONZOLA BAROVÉHO PULTU KOLMÁ	S	Cr,Crm,Nim	50	250

KONZOLA BAROVÉHO PULTU



Artik. číslo	Názov	Materiál	Povrch. úprava	mm
89 00 1 3x	KONZOLA BAROVÉHO PULTU KOLMÁ	S	Cr,Crm,li	200

KONZOLA BAROVÉHO PULTU



Artik. číslo	Názov	Materiál	Povrch. úprava	mm
89 00 1 xx	KONZOLA BAROVÉHO PULTU ŠIKMÁ	S	Cr,Crm,li	200

UPEVNENIE K PRACOVNEJ DOSKE



Artik. číslo	Názov	Materiál	Povrch. úprava	∅		
19 31 8 4x	UPEVNENIE K PRACOVNEJ DOSKE	S	Cr	53/69		14

KRYCIA OBJÍMKA



Artik. číslo	Názov	Materiál	Povrch. úprava	∅		
19 31 8 6x	KRYCIA OBJÍMKA	S, P	Cr	50/66	-	24

UPEVNENIE DOLNÉ



Artik. číslo	Názov	Materiál	Povrch. úprava	∅		
19 31 8 1x	UPEVNENIE DOLNÉ	S	Cr	50/90	-	27

UPEVŇOVACIA OBJÍMKA



Artik. číslo	Názov	Materiál	Povrch. úprava	∅		
19 31 8 5x	UPEVŇOVACIA OBJÍMKA	S	Cr	50/66	-	20

KRYTKA NA STĹP



Artik. číslo	Názov	Materiál	Povrch. úprava	∅		
19 31 8 8x	KRYTKA NA STĹP	S	Cr	50/66	-	23

KÔŠ NA STĹP CENTRÁLNY

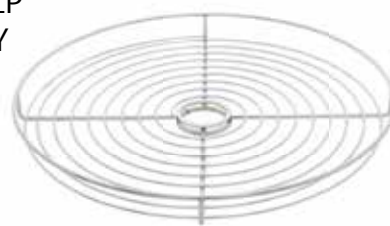

Artik. číslo	Názov	Materiál	Povrch. úprava	∅		
19 31 9 0x	KÔŠ NA STĹP CENTRÁLNY ∅ 350	S	Cr	350		34
19 31 9 5x	KÔŠ NA STĹP CENTRÁLNY ∅ 450	S	Cr	450		34

KÔŠ NA STĹP BOČNÝ



Artik. číslo	Názov	Materiál	Povrch. úprava	∅		
19 31 9 1x	KÔŠ NA STĹP BOČNÝ ∅ 350	S	Cr	350	-	34
19 31 9 6x	KÔŠ NA STĹP BOČNÝ ∅ 450	S	Cr	450	-	34

POLICA NA STĹP SKLENÁ

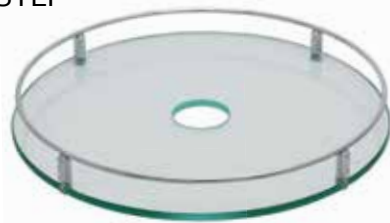

Artik. číslo	Názov	Materiál	Povrch. úprava	∅		
19 31 9 2x	POLICA NA STĹP SKLENÁ	S	Cr	350	-	39
19 31 9 7x	POLICA NA STĹP SKLENÁ	S	Cr	450	-	39

POLICA NA STĹP DREVENÁ



Artik. číslo	Názov	Materiál	Povrch. úprava	∅		
19 31 9 3x	POLICA NA STĹP DREVENÁ	S, W	Cr	350	-	45
19 31 9 8x	POLICA NA STĹP DREVENÁ	S, W	Cr	450	-	45

KÔŠ NA STĹP NA POHÁRE

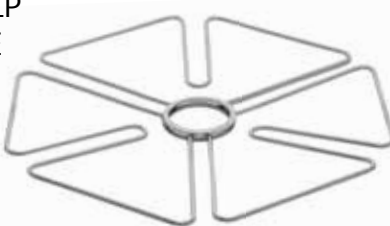

Artik. číslo	Názov	Materiál	Povrch. úprava	∅		
19 31 9 4x	KÔŠ NA STĹP NA POHÁRE	S	Cr	350	-	4

STĽP



Artik. číslo	Názov	Materiál	Povrch. úprava	∅		
19 31 5 1x	STĽP ∅ 50/3000 mm	S	Cr	50	-	3000

KRYT NA UPEVNENIE HORNÉ



Artik. číslo	Názov	Materiál	Povrch. úprava	∅		
19 31 8 7x	KRYT NA UPEVNENIE HORNÉ	S	Cr	50/66	-	82

UPEVNENIE BOČNÉ K STĽPU



Artik. číslo	Názov	Materiál	Povrch. úprava	∅		
19 31 8 3x	UPEVNENIE BOČNÉ K STĽPU	S	Cr	50	245	66

UPEVNENIE HORNÉ



Artik. číslo	Názov	Materiál	Povrch. úprava	∅		
19 31 8 2x	UPEVNENIE HORNÉ	S, P	-	50	-	-



KÔŠ NA ODPAD AUTOMAT



Artik. číslo	Názov	Materiál	Povrch. úprava		∅	
19 10 8 08	KÔŠ NA ODPAD AUTOMAT	P	šedá	-	277	345
19 00 0 10	KÔŠ NA ODPAD AUTOMAT	P	I	-	277	345

SPOJKA



Artik. číslo	Názov	Materiál	Povrch. úprava	∅			
19 01 3 04	SPOJKA	P	čierna	13	25	-	

KONCOVKA RETRO



Artik. číslo	Názov	Materiál	Povrch. úprava	∅			
19 01 3 02	KONCOVKA RETRO	Zn, P	Cr	24	-	-	

ÚCHYTKA RETRO



Artik. číslo	Názov	Materiál	Povrch. úprava	∅			
19 01 3 01	ÚCHYTKA RETRO	Zn	Cr	17/25	45	25	-

HÁČIK



Artik. číslo	Názov	Materiál	Povrch. úprava	∅			
19 01 3 03	HÁČIK	S	Cr	-	-	-	-

MADLO 90°



Artik. číslo	Názov	Materiál	Povrch. úprava	∅			
19 01 3 90	MADLO 90°	S	Cr	16	-	-	

MADLO



Artik. číslo	Názov	Materiál	Povrch. úprava	∅			
19 01 3 00	MADLO	S	Cr	16	1000	-	-
19 01 3 60	MADLO	S	Cr	16	600	-	-

DRŽIAK NA KUCHYNSKÉ DOPLNKY



Artik. číslo	Názov	Materiál	Povrch. úprava	∅			
19 12 3 11	DRŽIAK NA KUCHYNSKÉ DOPLNKY	S	Cr	112	125	240	

DRŽIAK NA KRÁJACIU DOSKU



Artik. číslo	Názov	Materiál	Povrch. úprava				
19 12 3 12	DRŽIAK NA KRÁJACIU DOSKU	S	Cr	80	80	145	

DRŽIAK NA POHÁRE VEĽKÝ



Artik. číslo	Názov	Materiál	Povrch. úprava				
19 12 3 27	DRŽIAK NA POHÁRE VEĽKÝ	S	Cr	450	200	100	

DRŽIAK NA POHÁRE MALÝ



Artik. číslo	Názov	Materiál	Povrch. úprava				
19 12 3 25	DRŽIAK NA POHÁRE MALÝ	S	Cr	154	200	100	

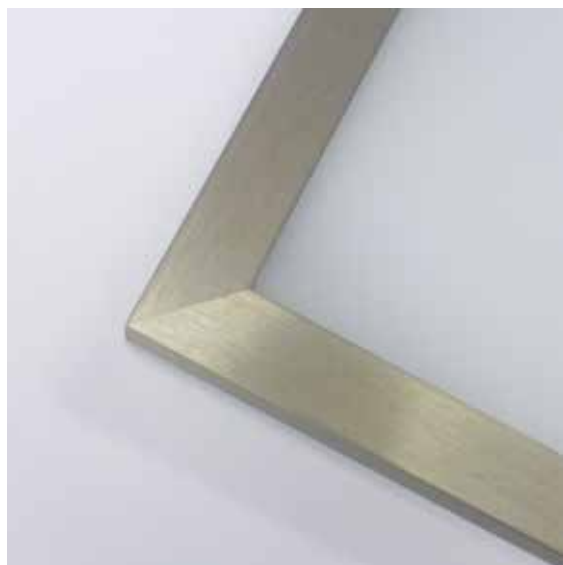

HLINÍKOVÉ RÁMIKY A PROFILY
ALUMINIUM FRAMES

R-1



Artik. číslo	Názov	Materiál	Povrch. úprava	Min. rozmer	Max. rozmer
*	R-1	Al	Crn, li, čierna	150	2500

R-2

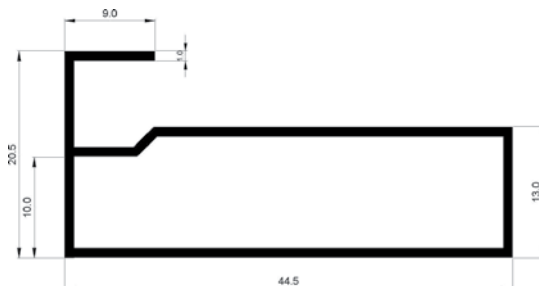

Artik. číslo	Názov	Materiál	Povrch. úprava	Min. rozmer	Max. rozmer
*	R-2	Al	Crn	150	2500

R-3



Artik. číslo	Názov	Materiál	Povrch. úprava	Min. rozmer	Max. rozmer
*	R-3	Al	Crn	150	2500

R-4

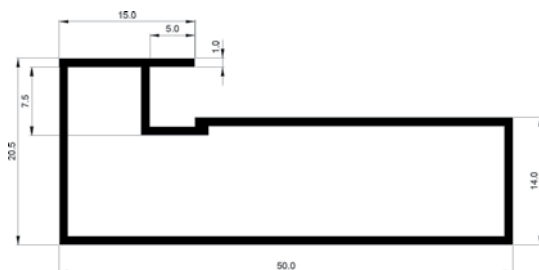

Artik. číslo	Názov	Materiál	Povrch. úprava	Min. rozmer	Max. rozmer
*	R-4	Al	Crn, li, čierna	150	2500

R-5



Artik. číslo	Názov	Materiál	Povrch. úprava	Min. rozmer	Max. rozmer
*	R-5	Al	Crn, čierna	150	2500

R-6

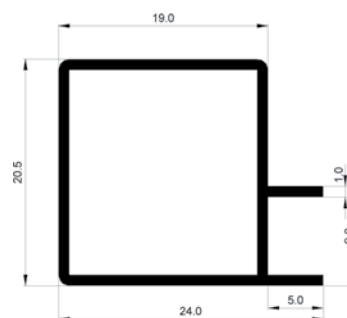

Artik. číslo	Názov	Materiál	Povrch. úprava	Min. rozmer	Max. rozmer
*	R-6	Al	Crn	150	2500

R-7

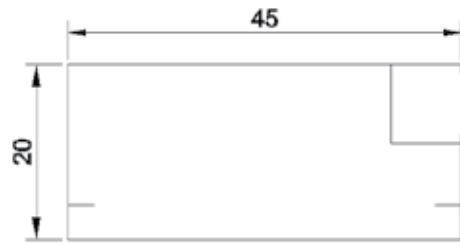

Artik. číslo	Název	Materiál	Povrch. úprava	Min. rozmer	Max. rozmer
*	R-1	Al	Crn, li, čierna	150	2500

R-10

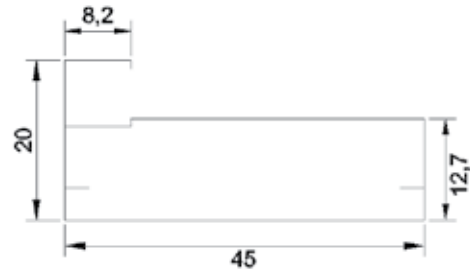

Artik. číslo	Název	Materiál	Povrch. úprava	Min. rozmer	Max. rozmer
*	R-1	Al	Crn, li, čierna	150	2500

R-50

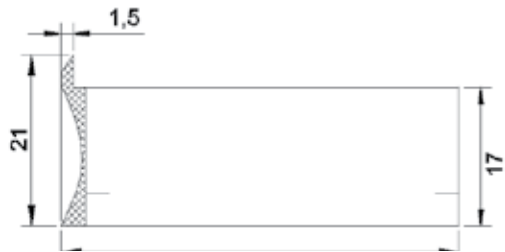

Artik. číslo	Název	Materiál	Povrch. úprava	Min. rozmer	Max. rozmer
*	R-1	Al	Crn, li, čierna	150	2500

R-55

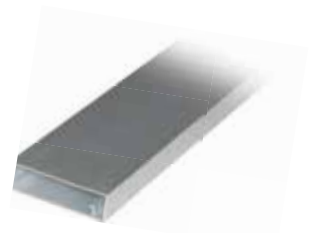

Artik. číslo	Název	Materiál	Povrch. úprava	Min. rozmer	Max. rozmer
*	R-1	Al	Crn, li, čierna	150	2500

Profil 40x40



Artik. číslo	Název	Materiál	Povrch. úprava	Min. rozmer	Max. rozmer
*	Profil 40x40	Al	Crn	150	2500
*	Profil 60x60	Al	Crn	150	2500

Profil Ø 60



Artik. číslo	Název	Materiál	Povrch. úprava	Min. rozmer	Max. rozmer
*	Profil Ø 60	Al	Crn	150	2500

Profil Gomera



Artik. číslo	Název	Materiál	Povrch. úprava	Min. rozmer	Max. rozmer
*	Profil Gomera	Al	C	-	2500

Profil FAB



Artik. číslo	Název	Materiál	Povrch. úprava	Min. rozmer	Max. rozmer
*	Profil FAB	Al	C	-	2500

HLINÍKOVÝ PROFIL

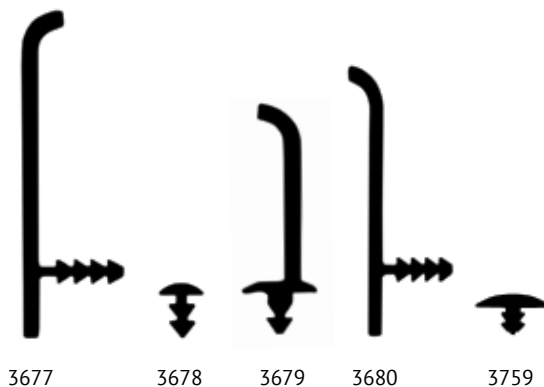

Artik. číslo	Názov	Materiál	Povrch. úprava	2000	12	39
16 17 1 10	Hliníkový profil 3677/2000mm	Al	Crn	2000	12	39
16 17 1 11	Hliníkový profil 3678/2000mm	Al	Crn	2000	9	27
16 17 1 12	Hliníkový profil 3679/2000mm	Al	Crn	2000	5	7
16 17 1 13	Hliníkový profil 3680/2000mm	Al	Crn	2000	13	32
16 17 1 16	Hliníkový profil 3759/2000mm	Al	Crn	2000	8	5

SKLO

ral 1013	ral 1015	ral 1023	ral 1236	ral 2001	ral 3004
Lacobel	Lacobel	Lacobel	Lacobel	Lacobel	Lacobel

ral 4007	ral 7000	ral 7013	ral 7035	ral 8017	ral 9003
Lacobel	Lacobel	Lacobel	Lacobel	Lacobel	Lacobel

ral 9005	ral 9006	ral 9007	ral 9010	ref 1164	ref 1586
Lacobel	Lacobel	Lacobel	Lacobel	Lacobel	Lacobel

ref 2232	ref 0337	fialová	ružová	strieborná	bronzová
Lacobel	Lacobel	Lacobel 4M01	Lacobel RAL 4406	Zrkadlo	Zrkadlo

grafitová	grafitová	bezfarebný	hnedá	piesková
Zrkadlo	Zrkadlo Clearvision	FLOAT	FLOAT	FLOAT



Mastercarre



Lacomat

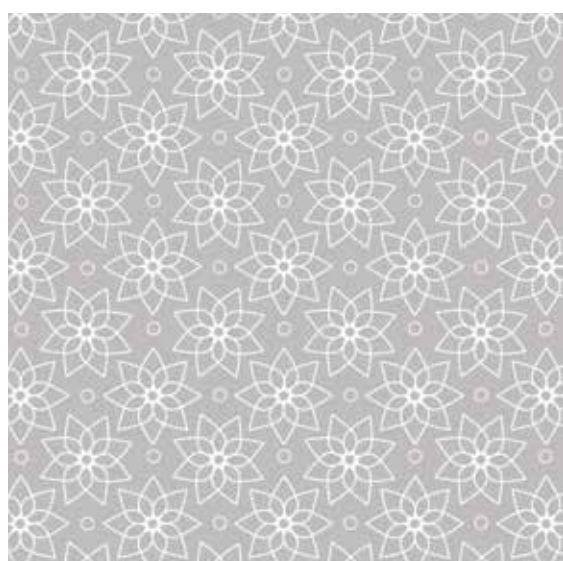
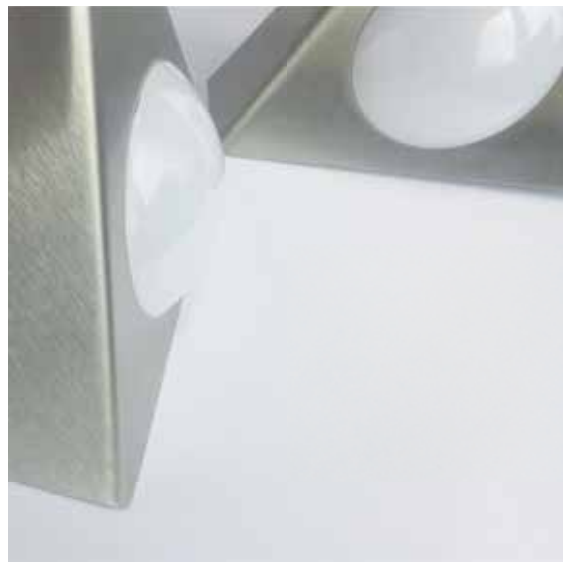
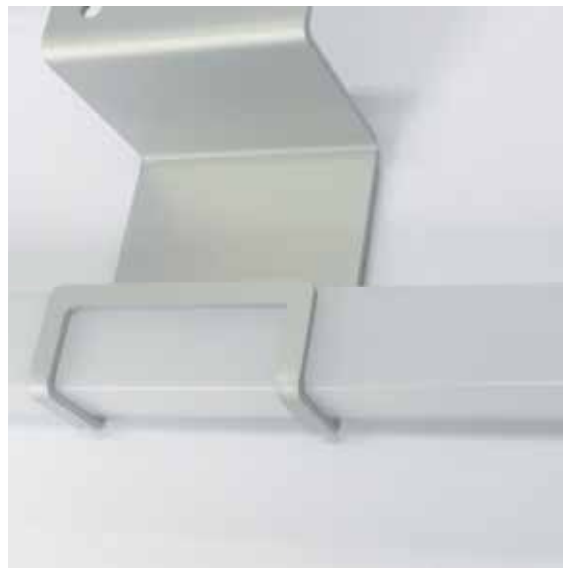











LED OSVETLENIE

LED LIGHTS

LED pásiky samolepiace

-60 LED/m resp. 120LED/m, napätie: 12V, vyžarovací uhol 120°
-základné balenie 5m, deliteľnosť 5cm, resp. 2,5 cm

	Príkon	Svietivosť	Šírka	Farba svetla	Kód
 gélové krytie: IP 65, SMD 3528	4,8 W/m	240-300lm/m	10mm	<div style="display: flex; flex-direction: column; gap: 5px;"> <div>■ modrá (465-470nm)</div> <div>■ žltá (590-595nm)</div> <div>■ zelená (515-520nm)</div> <div>■ červená (625-630nm)</div> </div>	8900085 8900087 8900086 8900088
 gélové krytie: IP 65, SMD 5050	11,8 W/m	520-600lm/m	10mm	■ RGB	8900082
 krytie: IP 20, SMD 3528	4,8 W/m	420-480lm/m	8mm	<div style="display: flex; flex-direction: column; gap: 5px;"> <div> denná biela (5500-6500K)</div> <div> teplá biela (2900-3200K)</div> </div>	8900064 8900063
 gélové krytie: IP 65, SMD 3528	4,8 W/m	420-480lm/m	10mm	<div style="display: flex; flex-direction: column; gap: 5px;"> <div> denná biela (5500-6500K)</div> <div> teplá biela (2900-3200K)</div> </div>	8900150 8900149
 krytie IP 20, SMD 3014	6 W/m	680-720lm/m	8mm	 denná biela (5500-6500K)	8900195
 krytie: IP 20, SMD 3528, 120LED/m	9,6 W/m	820-860lm/m	10mm	<div style="display: flex; flex-direction: column; gap: 5px;"> <div> denná biela (5500-6500K)</div> <div> teplá biela (2900-3200K)</div> </div>	8900060 8900059
 krytie IP20, SMD 3328	14 W/m	1430-1500lm/m	8mm	<div style="display: flex; flex-direction: column; gap: 5px;"> <div> denná biela (5500-6500K)</div> <div> teplá biela (2900-3200K)</div> </div>	8900196 8900197
 vysoká svietivosť, krytie: IP 20, SMD 5050	14,4 W/m	1160-1280lm/m	10mm	<div style="display: flex; flex-direction: column; gap: 5px;"> <div> denná biela (5500-6500K)</div> <div> teplá biela (2900-3200K)</div> </div>	8900061 8900148
 krytie: IP 20, SMD 5630	18 W/m	2520-2700lm/m	10mm	<div style="display: flex; flex-direction: column; gap: 5px;"> <div> denná biela (5500-6500K)</div> <div> teplá biela (2900-3200K)</div> </div>	8900091 8900132
 krytie IP20, SMD 3328, 120LED/m	24 W/m	2850-3000lm/m	10mm	<div style="display: flex; flex-direction: column; gap: 5px;"> <div> denná biela (5500-6500K)</div> <div> teplá biela (2900-3200K)</div> </div>	8900198 8900199

LED pásiky samolepiace

-60 LED/m resp. 120 LED/m, napätie: 24V, vyžarovací uhol 120°
-základné balenie 5m, deliteľnosť 5cm

Príkon Svietivosť Šírka Farba svetla Kód



krytie IP20, SMD 3328

14 W/m

1430-1500lm/m

8mm

denná biela
(5500-6500K)

[8900190](#)

teplá biela
(2900-3200K)

[8900191](#)



krytie IP20, SMD 5730

18 W/m

2520-2700lm/m

10mm

denná biela
(5500-6500K)

[8900192](#)



krytie IP20, SMD 3328, 120 LED/m

24 W/m

2850-3000lm/m

8mm

denná biela
(5500-6500K)

[8900193](#)

teplá biela
(2900-3200K)

[8900194](#)

Zdroje pre LED

Adaptér spínaný

Parametre

Typ

Kód



12V/6W/0,5A

SYS AC/DC

[8900072](#)

12V/12W/1,0A

SYS AC/DC

[8900073](#)

12V/24W/2,08A

SYS AC/DC

[8900074](#)

Spínaný zdroj

Parametre

Typ

Kód



12V/12W/1A

APV-12-12

[8900071](#)

12V/18W/1,5A

LPH 18W

[8900119](#)

12V/25W/2,1A

APV-25-12

[8900070](#)

12V/35W/2,91A

LPV 35W

[8900069](#)

12V/60W/5,0A

LPV 60W

[8900068](#)

12V/100W/8,33A

LPV 100W

[8900067](#)



24V/25W/1,05A

APV-25-24

[8900242](#)

24V/60W/2,5A

LPV 60W

[8900243](#)

24V/100W/4,2A

LPV 100W

[8900244](#)

Spínaný zdroj

Parametre

Typ

Kód

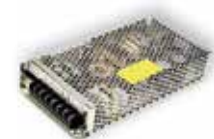

12V/100W/8,3A

RS-100-12

[8900152](#)

12V/150W/12,5A

RS-150-12

[8900155](#)

24V/200W/8,3A

RSP-200-24

[8900245](#)

Profily pre LED

Profil SURFACE

Kryty do profilu SURFACE



Pás krycí číry, naklapávací, dĺžka 2m [8900130](#)

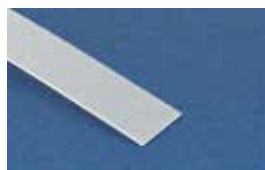

Pás krycí námraza, nasúvací, dĺžka 2m [8900066](#)



Pás krycí číry, nasúvací, dĺžka 2m [8900090](#)

Profil pre LED, vrchná montáž, dĺžka 2m/ks, al. elox [8900050](#)



Koncovka profilu plastová [8900056](#)



Príchytko lišty oceľová [8900127](#)

Profil GROOVE

Kryty do profilu GROOVE

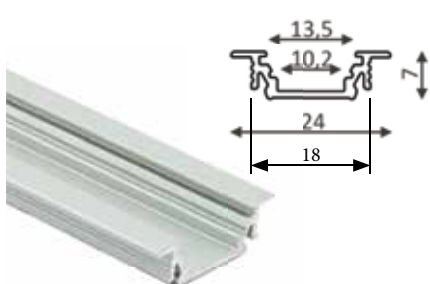

Pás krycí číry, naklapávací, dĺžka 2m [8900130](#)



Pás krycí námraza, nasúvací, dĺžka 2m [8900066](#)



Pás krycí číry, nasúvací, dĺžka 2m [8900090](#)

Profil pre LED k zafrézovaniu, dĺžka 2m/ks, al. elox [8900049](#)



Koncovka profilu plastová [8900055](#)

Profil CORNER

Kryty do profilu CORNER

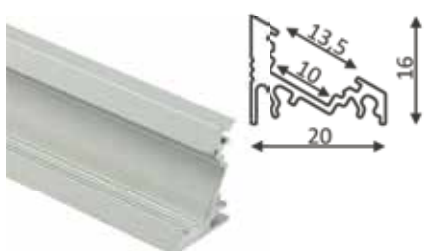

Pás krycí číry, naklapávací, dĺžka 2m [8900130](#)

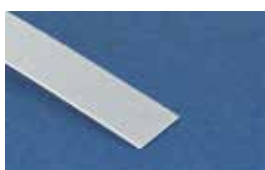

Pás krycí námraza, nasúvací, dĺžka 2m [8900066](#)



Pás krycí číry, nasúvací, dĺžka 2m [8900090](#)

Profil pre LED rohový (uhol 30° alebo 60°), vrchná montáž, dĺžka 2m/ks, al. elox [8900048](#)



Koncovka profilu plastová [8900053](#)



Príchytko lišty oceľová [8900127](#)

Profil SLIM

Kryt do profilu SLIM

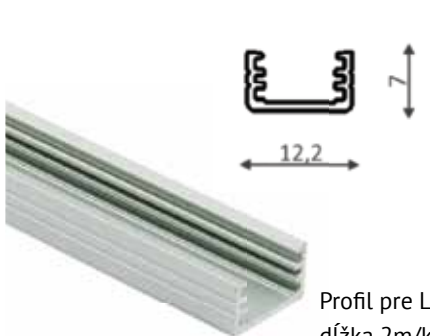

Pás krycí námraza, nasúvací, dĺžka 2m [8900092](#)



Koncovka profilu plastová [8900099](#)

Profil pre LED, vrchná mont., aj k zafrézovaniu, dĺžka 2m/ks, al. elox [8900098](#)

Profil MIKRO

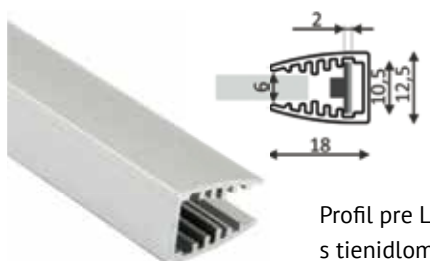

Koncovka profilu plastová [8900057](#)

Profil pre LED, pre sklo 6mm (sklenenej police) s tienidlom, dĺžka 2m/ks, al. elox [8900052](#)

Profil SQUARE-HM

Kryty do profilu SQUARE-HM

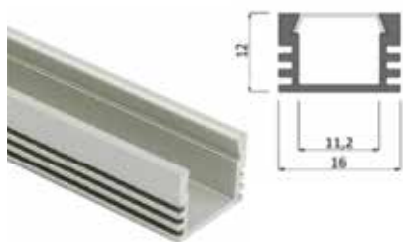

Pás krycí číry, naklapávací, dĺžka 2m [8900093](#)



Pás krycí námraza, naklapávací, dĺžka 2m [8900095](#)



Pás krycí mliečny, naklapávací, dĺžka 2m [8900076](#)

Profil pre LED, vrchná montáž, dĺžka 2m/ks, al. elox [8900106](#)



Koncovka profilu plastová, bez otvoru [8900107](#), s otvorom na kábel [8900108](#)



Príchytka lišty oceľová [8900182](#)

Profil SQUARE-FR

Kryty do profilu SQUARE-FR

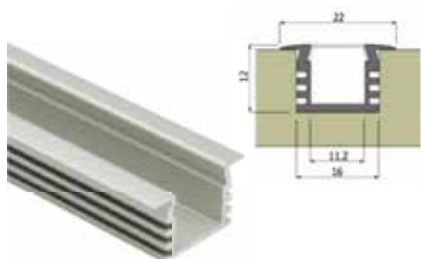

Pás krycí číry, naklapávací, dĺžka 2m [8900093](#)



Pás krycí námraza, naklapávací, dĺžka 2m [8900095](#)



Pás krycí mliečny, naklapávací, dĺžka 2m [8900076](#)

Profil pre LED, k zafrézovaniu, dĺžka 2m/ks, al. elox [8900109](#)



Koncovka profilu plastová, bez otvoru [8900110](#), s otvorom na kábel [8900111](#)

Profil FLAT-HM

Kryty do profilu FLAT-HM



Pás krycí číry, naklapávací, dĺžka 2m [8900093](#)



Pás krycí námraza, naklapávací, dĺžka 2m [8900095](#)



Pás krycí mliečny, naklapávací, dĺžka 2m [8900076](#)

Profil pre LED, vrchná montáž, dĺžka 2m/ks, al. elox [8900163](#)



Koncovka profilu plastová, bez otvoru [8900164](#), s otvorom na kábel [8900165](#)



Príchytka lišty oceľová [8900182](#)

Profil ANGLE 45

Kryty do profilu ANGLE 45



Pás krycí číry, naklapávací, dĺžka 2m [8900093](#)



Pás krycí námraza, naklapávací, dĺžka 2m [8900095](#)



Pás krycí mliečny, naklapávací, dĺžka 2m [8900076](#)

Profil pre LED, rohový (uhol 45°), dĺžka 2m/ks, al. elox [8900112](#)



Koncovka profilu plastová, bez otvoru [8900113](#), s otvorom na kábel [8900114](#)



Príchytka lišty oceľová [8900183](#)

Profil FLAT-FR

Kryty do profilu FLAT-FR

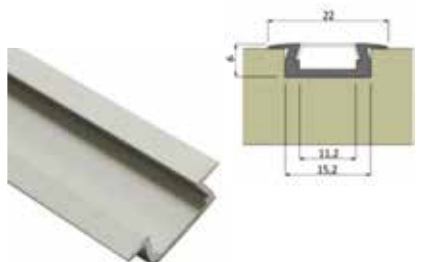

Pás krycí číry, naklapávací, dĺžka 2m [8900093](#)



Pás krycí námraza, naklapávací, dĺžka 2m [8900095](#)



Pás krycí mliečny, naklapávací, dĺžka 2m [8900076](#)

Profil pre LED, k zafrézovaniu, dĺžka 2m/ks, al. elox [8900166](#)



Koncovka profilu plastová, bez otvoru [8900167](#), s otvorom na kábel [8900168](#)

Profil SQUARE 2-HM

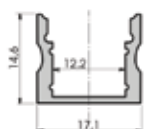

Profil pre LED, vrchná montáž,
dĺžka 2m/ks, al. elox [8900210](#)



Koncovka profilu plastová, bez otvoru
[8900226](#), s otvorom na kábel [8900227](#)

Profil SQUARE 2-FR

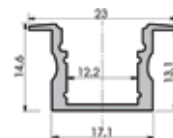
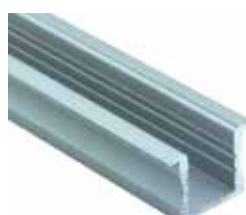

Profil pre LED, k zafrézovaniu,
dĺžka 2m/ks, al. elox [8900246](#)



Koncovka profilu plastová, bez otvoru
[8900228](#), s otvorom na kábel [8900229](#)

Profil FLAT 2-HM

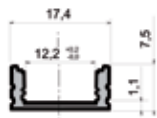

Profil pre LED, vrchná montáž,
dĺžka 2m/ks, al. elox [8900212](#)



Koncovka profilu plastová, bez otvoru
[8900222](#), s otvorom na kábel [8900223](#)

Profil FLAT 2-FR

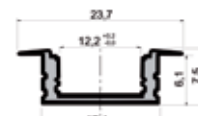

Profil pre LED, k zafrézovaniu,
dĺžka 2m/ks, al. elox [8900211](#)



Koncovka profilu plastová, bez otvoru
[8900224](#), s otvorom na kábel [8900225](#)

Profil ANGLE 2-45

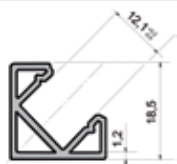

Profil pre LED, rohový (uhol 45°)
dĺžka 2m/ks, al. elox [8900213](#)



Koncovka profilu plastová, bez otvoru
[8900230](#), s otvorom na kábel [8900235](#)

Profil FLUO

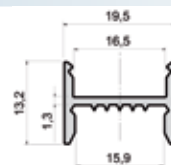

Profil pre LED, vrchná montáž,
dĺžka 2m/ks, al. elox [8900214](#)



Koncovka profilu plastová, bez otvoru
[8900186](#), s otvorom na kábel [8900187](#)

Kryty do profilu SQUARE 2-HM, SQUARE 2-FR, FLAT 2-HM, FLAT 2-FR



Pás krycí číry, naklapávací,
dĺžka 2m [8900216](#)



Pás krycí námraza, nakla-
pávací, dĺžka 2m [8900217](#)



Pás krycí mliečny, nakla-
pávací, dĺžka 2m [8900218](#)



Pás krycí mliečny, nakla-
pávací, dĺžka 2m [8900219](#)

Kryt do profilu FLUO, oblý



Pás krycí mliečny, nakla-
pávací, dĺžka 2m [8900220](#)



Koncovka profilu plastová, bez otvoru
[8900188](#) s otvorom na kábel [8900189](#)

Ovládače pre RGB pásiky

Jednotka pre riadenie LED RGB-IR

[8900156](#)



Výstupná hodnota: max 12V/72W
IR diaľkové ovládanie (infračervené)
24 tlačidiel

Jednotka pre riadenie LED RGB-IR

[8900159](#)



Výstupná hodnota: max 12V/72W
IR diaľkové ovládanie (infračervené)
44 tlačidiel

Jednotka pre riadenie LED RGB-RF

[8900157](#)



Výstupná hodnota: max 12V/144W
RF diaľkové ovládanie (rádiofrekvencné)-
-dosah až 20m, 11 programov

Stmievateľ pre LED s IF diaľkovým ovládaním 8A-jednokanálový

-vstupné napätie: 12V
-požiadavok na príkon nezaťaženého modulu: 1W
-výstupné hodnoty: 12V/96W (8A) max.
[8900169](#)



Miniatúrny spínač pre LED pásiky do profilov

Stmievateľ/spínač pre LED pásiky k zastaveniu do profilov, s mikrotlačítkom-12V, [8900116](#)

-prevádzka v dvoch režimoch
-napájacie napätie: 10-15V DC
-maximálny prúd: 10A (120W)
-rozsah regulácie: 0-100 %
-rozmery: 10x28x6mm



Spínacia jednotka pre senzory

-určené pre senzory: ND TC SO, ND TC SM a ND TC SD
-vstupné napätie: 12V DC
-max. zaťaženie: 12V/144W
-počet vstupov: 2
[8900123](#)



Senzor na mávnutie ND TC SM [8900122](#)

-reaguje na pohyb, prvý pohyb rozsvieti, druhým pohybom zhasne
-čelná, aj bočná montáž
-dĺžka kábla: 2m
-príslušenstvo: adaptér pre bočnú montáž



Senzor pre posuvné dvere ND TC SO [8900171](#)



-reaguje na odkrytie čidla, odkrytie rozsvieti, zakrytie zhasne
-čelná, aj bočná montáž
-dĺžka kábla: 2m
-príslušenstvo: adaptér pre bočnú montáž

Senzor dotykový ND TC SD [8900172](#)



-reaguje na dotyk, prvý dotyk rozsvieti, druhý zhasne
-čelná, aj bočná montáž
-dĺžka kábla: 2m
-príslušenstvo: adaptér pre boč. montáž

Svietidlá, lišty a LED tuby

Názov	Príkon/Napätie	Svietivosť	Farba svetla	Povrchová úprava	Kód
LLT 7	3,8 W/12 V DC	205 - 228 lm	<input type="checkbox"/> studená biela <input type="checkbox"/> teplá biela	INOX, hliník	NEW
OML9	3,8 W/12 V DC		<input type="checkbox"/> studená biela <input type="checkbox"/> teplá biela	hliník	NEW
OML2	3,8 W/12 V DC	227 - 255 lm	<input type="checkbox"/> studená biela <input type="checkbox"/> teplá biela	chróm, nikel brús.	NEW
OML5	1 W/10 V DC	21 - 23 lm	<input type="checkbox"/> studená biela <input type="checkbox"/> teplá biela	hliník	NEW
KL3	0,24 W/12 V DC		<input type="checkbox"/> studená biela <input type="checkbox"/> teplá biela	Zrkadlo (INOX)	NEW
LN1	5,8 W/12 V DC		<input type="checkbox"/> studená biela <input type="checkbox"/> teplá biela	hliník	NEW
LL2	3,4 W/12 V DC 4,8 W/12 V DC 7,7 W/12 V DC	207 - 230 lm 288 - 320 lm 441 - 490 lm	<input type="checkbox"/> studená biela <input type="checkbox"/> teplá biela	hliník	NEW
LL3	5,0 W/12 V DC 10,1 W/12 V DC 20,9 W/12 V DC	243 - 270 lm 486 - 540 lm 1008 - 1120 lm	<input type="checkbox"/> studená biela <input type="checkbox"/> teplá biela	hliník	NEW

Príslušenstvo



Napájací zdroj **ZOL19**
12V/1.6A/19W
[NEW](#)



Napájací zdroj **ZOL6**
10V/0.6A/6W
[NEW](#)



Bezkontaktný vypínač **S01**
Napájanie/max. výkon:
12V/24W 24V/30W
[NEW](#)



Spínač **LT1**
Povrchová úprava: INOX
230V/16A
[NEW](#)



Vypínač okrúhly kolískový **R13**
Farebné prevedenie: čierna/biela/
hneda
[NEW](#)



Zásuvka **GT1**
Povrchová úprava: INOX
230V/16A
[NEW](#)

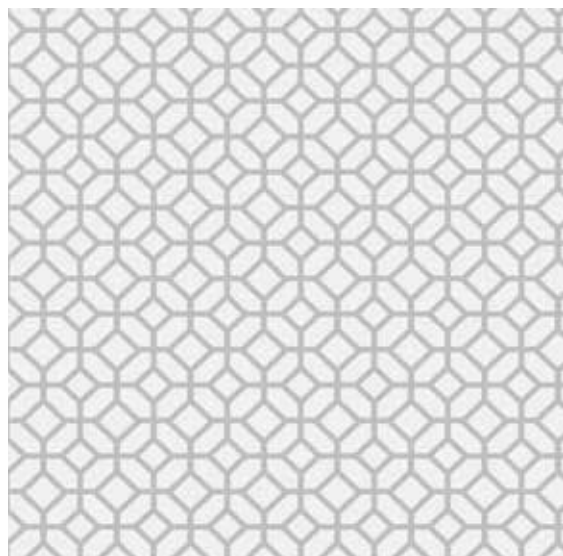
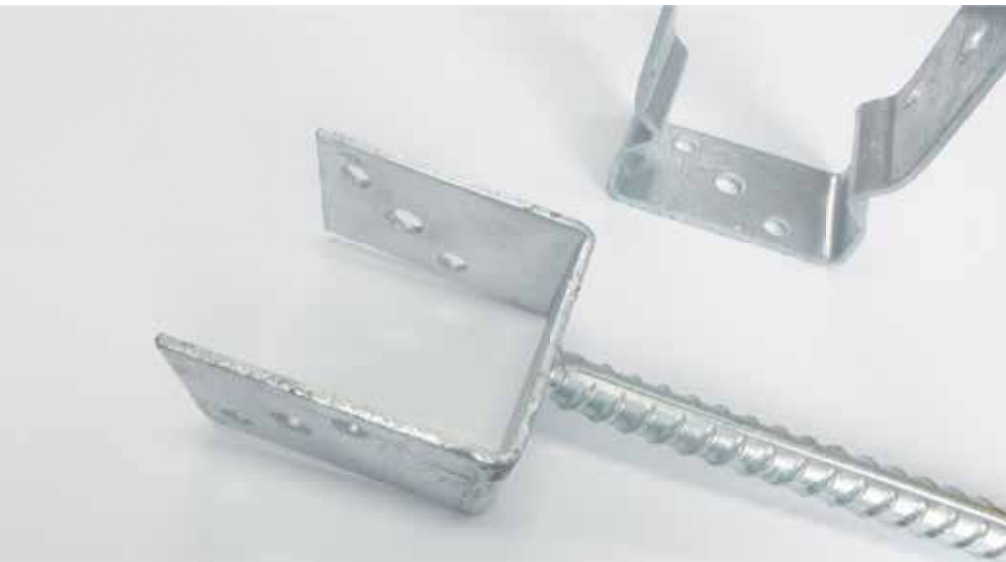
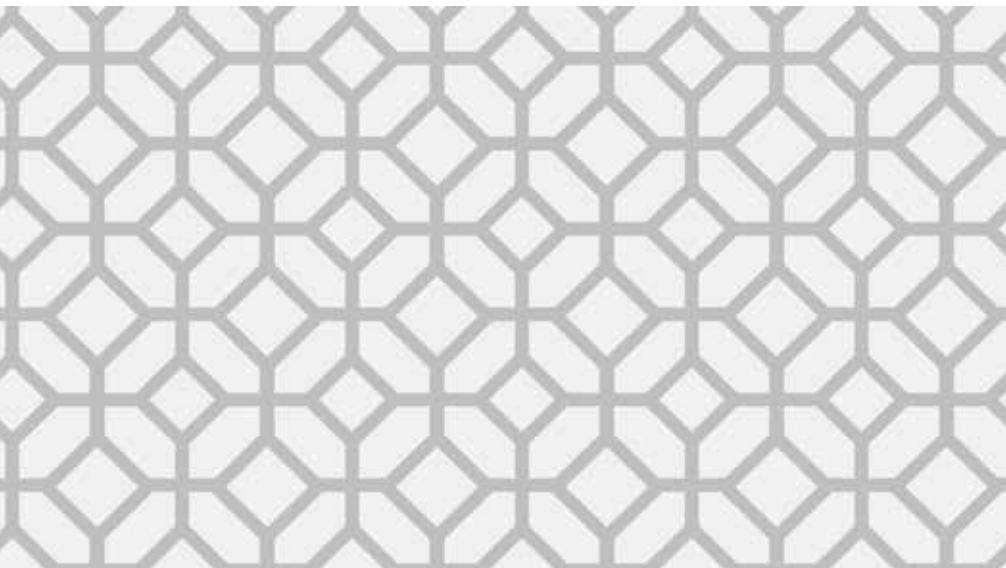

TESÁRSKE KOVANIE
CARPENTRY FITTINGS

UHOLNÍK NEPRAVIDELNÝ



Artik. číslo	Názov	Materiál	Povrch. úprava	Rozmer - hrúbka
930181041	UHOLNÍK NEPRAVIDELNÝ	S	Zn	40x80/60-3
930181042	UHOLNÍK NEPRAVIDELNÝ	S	Zn	40x120/60-3
930181043	UHOLNÍK NEPRAVIDELNÝ	S	Zn	40x160/60-3
930181044	UHOLNÍK NEPRAVIDELNÝ	S	Zn	40x200/60-4

UHOLNÍK MALÝ BEZ PRELISU



Artik. číslo	Názov	Materiál	Povrch. úprava	Rozmer - hrúbka
930181021	UHOLNÍK MALÝ BEZ PRELISU	S	Zn	35x50/50-2
930181022	UHOLNÍK MALÝ BEZ PRELISU	S	Zn	45x60/60-2
930181023	UHOLNÍK MALÝ BEZ PRELISU	S	Zn	55x70/70-2
930181024	UHOLNÍK MALÝ BEZ PRELISU	S	Zn	65x90/90-2,5
930181025	UHOLNÍK MALÝ BEZ PRELISU	S	Zn	90x105/105-3
930181031	UHOLNÍK MALÝ BEZ PRELISU	S	Zn	40x70/70-3
930181032	UHOLNÍK MALÝ BEZ PRELISU	S	Zn	40x110/110-3

UHOLNÍK VEĽKÝ BEZ PRELISU



Artik. číslo	Názov	Materiál	Povrch. úprava	Rozmer - hrúbka
930181001	UHOLNÍK VEĽKÝ BEZ PRELISU	S	Zn	40x40/40-2
930181002	UHOLNÍK VEĽKÝ BEZ PRELISU	S	Zn	60x40/40-2
930181003	UHOLNÍK VEĽKÝ BEZ PRELISU	S	Zn	40x60/60-2
930181004	UHOLNÍK VEĽKÝ BEZ PRELISU	S	Zn	60x60/60-2
930181005	UHOLNÍK VEĽKÝ BEZ PRELISU	S	Zn	80x60/60-2
930181006	UHOLNÍK VEĽKÝ BEZ PRELISU	S	Zn	40x80/80-2
930181007	UHOLNÍK VEĽKÝ BEZ PRELISU	S	Zn	60x80/80-2
930181008	UHOLNÍK VEĽKÝ BEZ PRELISU	S	Zn	80x80/80-2
930181009	UHOLNÍK VEĽKÝ BEZ PRELISU	S	Zn	100x80/80-2
930181010	UHOLNÍK VEĽKÝ BEZ PRELISU	S	Zn	120x80/80-2
930181011	UHOLNÍK VEĽKÝ BEZ PRELISU	S	Zn	100x100/100-2
930181012	UHOLNÍK VEĽKÝ BEZ PRELISU	S	Zn	160x100/100-3

UHOLNÍK S VEĽKÝM PRELISOM



Artik. číslo	Názov	Materiál	Povrch. úprava	Rozmer - hrúbka
930181051	UHOLNÍK S VEĽKÝM PRELISOM	S	Zn	35x50/50-2
930181052	UHOLNÍK S VEĽKÝM PRELISOM	S	Zn	45x60/60-2
930181053	UHOLNÍK S VEĽKÝM PRELISOM	S	Zn	55x70/70-2
930181054	UHOLNÍK S VEĽKÝM PRELISOM	S	Zn	65x90/90-2,5
930181055	UHOLNÍK S VEĽKÝM PRELISOM	S	Zn	90x105/105-3

ROHOVNÍK



Artik. číslo	Názov	Materiál	Povrch. úprava	Rozmer - hrúbka
930181081	ROHOVNÍK	S	Zn	85x85/32-2
930181082	ROHOVNÍK	S	Zn	130x130/32-2
930181083	ROHOVNÍK	S	Zn	170x170/33-2

DOSKA SPOJOVACIA "T"



Artik. číslo	Názov	Materiál	Povrch. úprava	Rozmer - hrúbka
930181161	DOSKA SPOJOVACIA "T"	S	Zn	160x98x45-2

DOSKA SPOJOVACIA



Artik. číslo	Názov	Materiál	Povrch. úprava	Rozmer - hrúbka
930181101	DOSKA SPOJOVACIA	S	Zn	35x100-2
930181102	DOSKA SPOJOVACIA	S	Zn	45x120-2
930181103	DOSKA SPOJOVACIA	S	Zn	55x140-2
930181104	DOSKA SPOJOVACIA	S	Zn	65x180-2,5
930181105	DOSKA SPOJOVACIA	S	Zn	90x200-3
930181121	DOSKA SPOJOVACIA	S	Zn	30x70-1,5
930181122	DOSKA SPOJOVACIA	S	Zn	40x200-2
930181123	DOSKA SPOJOVACIA	S	Zn	60x120-2
930181124	DOSKA SPOJOVACIA	S	Zn	60x300-2
930181125	DOSKA SPOJOVACIA	S	Zn	80x160-2
930181126	DOSKA SPOJOVACIA	S	Zn	80x300-2
930181127	DOSKA SPOJOVACIA	S	Zn	120x200-2
930181128	DOSKA SPOJOVACIA	S	Zn	120x280-2
930181129	DOSKA SPOJOVACIA	S	Zn	160x300-2
930181130	DOSKA SPOJOVACIA	S	Zn	160x380-2
930181111	DOSKA SPOJOVACIA ÚZKA	S	Zn	40x100-3
930181112	DOSKA SPOJOVACIA ÚZKA	S	Zn	40x140-3
930181113	DOSKA SPOJOVACIA ÚZKA	S	Zn	40x220-3

UHOLNÍK S MALÝM PRELISOM



Artik. číslo	Názov	Materiál	Povrch. úprava	Rozmer - hrúbka
930181061	UHOLNÍK S MALÝM PRELISOM	S	Zn	30x35/35-1,5
930181062	UHOLNÍK S MALÝM PRELISOM	S	Zn	70x35/35-1,5
930181063	UHOLNÍK S MALÝM PRELISOM	S	Zn	120x35/35-1,5
930181064	UHOLNÍK S MALÝM PRELISOM	S	Zn	40x53/53-1,5
930181065	UHOLNÍK S MALÝM PRELISOM	S	Zn	100x53/53-1,5
930181066	UHOLNÍK S MALÝM PRELISOM	S	Zn	140x53/53-1,5
930181067	UHOLNÍK S MALÝM PRELISOM	S	Zn	50x70/70-1,5



KLINEC KONVEKNÝ 4x40 - 90 (mm)

DOSKA STYČNÍKOVÁ

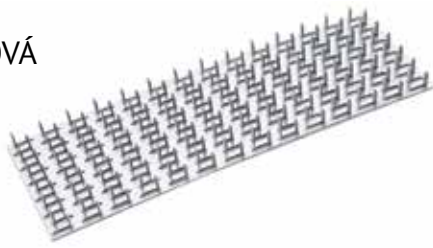

Artik. číslo	Názov	Materiál	Povrch. úprava	Rozmer - hrúbka
930181151	DOSKA STYČNÍKOVÁ	S	Zn	24x60-1
930181152	DOSKA STYČNÍKOVÁ	S	Zn	54x90-1
930181153	DOSKA STYČNÍKOVÁ	S	Zn	70x168-1,5
930181154	DOSKA STYČNÍKOVÁ	S	Zn	105x210-1,5
930181155	DOSKA STYČNÍKOVÁ	S	Zn	24x105-1
930181156	DOSKA STYČNÍKOVÁ	S	Zn	24x210-1
930181157	DOSKA STYČNÍKOVÁ	S	Zn	72x210-1
930181158	DOSKA STYČNÍKOVÁ	S	Zn	35x126-1,5
930181159	DOSKA STYČNÍKOVÁ	S	Zn	126x252-1,5
930181160	DOSKA STYČNÍKOVÁ OBOJSTRANNÁ	S	Zn	35x84-1,5

BULLDOG-SPOJKA ZUBOVÁ



Artik. číslo	Názov	Materiál	Povrch. úprava	Rozmer - hrúbka
930181201	BULLDOG-SPOJKA ZUBOVÁ	S	Zn	50/17-1
930181202	BULLDOG-SPOJKA ZUBOVÁ	S	Zn	75/23-1,3
930181203	BULLDOG-SPOJKA ZUBOVÁ	S	Zn	95/36-1,5

SPOJKA KROKVOVÁ



Artik. číslo	Názov	Materiál	Povrch. úprava	Rozmer - hrúbka
930181171	SPOJKA KROKVOVÁ PRAVÁ	S	Zn	130x32,5-3
930181172	SPOJKA KROKVOVÁ ĽAVÁ	S	Zn	130x32,5-3
930181173	SPOJKA KROKVOVÁ PRAVÁ	S	Zn	170x32,5-3
930181174	SPOJKA KROKVOVÁ ĽAVÁ	S	Zn	170x32,5-3
930181175	SPOJKA KROKVOVÁ PRAVÁ	S	Zn	210x32,5-3
930181176	SPOJKA KROKVOVÁ ĽAVÁ	S	Zn	210x32,5-3

NOSNÍK TRÁMOVÝ -PAPUČA



Artik. číslo	Názov	Materiál	Povrch. úprava	Rozmer - hrúbka
930181181	NOSNÍK TRÁMOVÝ-PAPUČA	S	Zn	60x120-2
930181182	NOSNÍK TRÁMOVÝ-PAPUČA	S	Zn	80x80-2
930181183	NOSNÍK TRÁMOVÝ-PAPUČA	S	Zn	80x100-2
930181184	NOSNÍK TRÁMOVÝ-PAPUČA	S	Zn	80x120-2
930181185	NOSNÍK TRÁMOVÝ-PAPUČA	S	Zn	80x140-2
930181186	NOSNÍK TRÁMOVÝ-PAPUČA	S	Zn	80x160-2
930181187	NOSNÍK TRÁMOVÝ-PAPUČA	S	Zn	80x180-2
930181188	NOSNÍK TRÁMOVÝ-PAPUČA	S	Zn	100x100-2
930181192	NOSNÍK TRÁMOVÝ-PAPUČA	S	Zn	120x120-2
930181194	NOSNÍK TRÁMOVÝ-PAPUČA	S	Zn	140x140-2

PÁS ZAVETROVACÍ



Artik. číslo	Názov	Materiál	Povrch. úprava	Rozmer - hrúbka
930181221	PÁS ZAVETROVACÍ	S	Zn	40x1m-2
930181222	PÁS ZAVETROVACÍ	S	Zn	40x50m-2

PÁS ZÁVESNÝ



Artik. číslo	Názov	Materiál	Povrch. úprava	Rozmer - hrúbka
930181231	PÁS ZÁVESNÝ	S	Zn	12x10m-0,7
930181232	PÁS ZÁVESNÝ	S	Zn	17x10m-0,7

PÁS MONTÁŽNY



Artik. číslo	Názov	Materiál	Povrch. úprava	Rozmer - hrúbka
930181211	PÁS MONTÁŽNY	S	Zn	12x3m-0,7
930181212	PÁS MONTÁŽNY	S	Zn	12x10m-0,7

PÄTKA ŠTVORCOVÁ



Artik. číslo	Názov	Materiál	Povrch. úprava	Rozmer - hrúbka
930180251	PÄTKA ŠTVORCOVÁ	S	Zn	70x70x150-3
930180252	PÄTKA ŠTVORCOVÁ	S	Zn	90x90x150-3
930180253	PÄTKA ŠTVORCOVÁ	S	Zn	100x100x150-3



VRUT - ZAPUSTENÁ HLAVA 8x80 - 300 (mm)

PÄTKA "U" NA PRISKRUTKOVANIE



Artik. číslo	Názov	Materiál	Povrch. úprava	Rozmer - hrúbka
930180172	PÄTKA "U" S PRELISOM	S	Zn	80x80x120-4
930180173	PÄTKA "U" S PRELISOM	S	Zn	100x100x120-4
930180174	PÄTKA "U" S PRELISOM	S	Zn	120x120x120-4
930180175	PÄTKA "U" S PRELISOM	S	Zn	140x120x120-4
930180181	PÄTKA "U" S PRELISOM ÚZKA	S	Zn	70x60x150-5
930180182	PÄTKA "U" S PRELISOM ÚZKA	S	Zn	80x60x150-5
930180183	PÄTKA "U" S PRELISOM ÚZKA	S	Zn	90x60x150-5
930180184	PÄTKA "U" S PRELISOM ÚZKA	S	Zn	100x60x150-5
930180185	PÄTKA "U" S PRELISOM ÚZKA	S	Zn	120x60x150-5
930180191	PÄTKA "U" ŠIROKÁ ROVNÁ	S	Zn	60x60x120-4
930180192	PÄTKA "U" ŠIROKÁ ROVNÁ	S	Zn	80x80x120-4
930180193	PÄTKA "U" ŠIROKÁ ROVNÁ	S	Zn	100x100x120-4
930180194	PÄTKA "U" ŠIROKÁ ROVNÁ	S	Zn	120x120x120-4

PÄTKA "U" NA ZABETÓNOVANIE



Artik. číslo	Názov	Materiál	Povrch. úprava	Rozmer dosky / rozmer kolíka
930180101	PÄTKA "U"	S	Zn	60x60x125/ø16x250
930180102	PÄTKA "U"	S	Zn	80x80x125/ø16x250
930180103	PÄTKA "U"	S	Zn	100x100x125/ø16x250
930180104	PÄTKA "U"	S	Zn	120x120x125/ø20x250
930180105	PÄTKA "U"	S	Zn	140x120x125/ø20x250
930180111	PÄTKA "U" ÚZKA	S	Zn	60x60x100/ø18x200
930180112	PÄTKA "U" ÚZKA	S	Zn	70x60x100/ø18x200
930180113	PÄTKA "U" ÚZKA	S	Zn	80x60x100/ø18x200
930180114	PÄTKA "U" ÚZKA	S	Zn	90x60x100/ø18x200
930180115	PÄTKA "U" ÚZKA	S	Zn	100x60x100/ø18x200
930180116	PÄTKA "U" ÚZKA	S	Zn	120x60x100/ø18x200
930180117	PÄTKA "U" ÚZKA	S	Zn	140x60x100/ø18x200
930180141	PÄTKA "U" S PRELISOM	S	Zn	60x60x125/ø16x250
930180142	PÄTKA "U" S PRELISOM	S	Zn	80x80x125/ø16x250
930180143	PÄTKA "U" S PRELISOM	S	Zn	100x100x125/ø16x250
930180144	PÄTKA "U" S PRELISOM	S	Zn	120x120x125/ø20x250
930180145	PÄTKA "U" S PRELISOM	S	Zn	140x120x125/ø20x250

PÄTKA "T" VÝŠKOVO NASTAVITELNÁ



Artik. číslo	Názov	Materiál	Povrch. úprava	Hrúbka dosky	Rozmer dosky / rozmer kolíka
930180171	PÄTKA "T"-VÝŠK. NASTAV.	S	Zn	8	80x100x110/120-180/M20
930180151	PÄTKA "T" NA ZABETÓN.	S	Zn	-	70x70x130/ø20x200
930180152	PÄTKA "T" NA ZABETÓN.	S	Zn	8	90x90x130/ø20x200

PÄTKA S PEVNOU DOSKOU VÝŠKOVO NASTAVITELNÁ



Artik. číslo	Názov	Materiál	Povrch. úprava	Rozmer dosky / rozmer kolíka
930180001	PÄTKA S PEVNOU DOSKOU	S	Zn	110x110/M24x200
930180002	PÄTKA S PEVNOU DOSKOU	S	Zn	110x110/M24x250
930180003	PÄTKA S PEVNOU DOSKOU	S	Zn	110x110/M24x330
930180004	PÄTKA S PEVNOU DOSKOU	S	Zn	80x80/M16x100
930180005	PÄTKA S PEVNOU DOSKOU	S	Zn	80x80/M16x160
930180006	PÄTKA S PEVNOU DOSKOU	S	Zn	80x80/M20x200
930180007	PÄTKA S PEVNOU DOSKOU	S	Zn	80x80/M24x200
930180008	PÄTKA S PEVNOU DOSKOU	S	Zn	80x80/M24x250
930180009	PÄTKA S PEVNOU DOSKOU	S	Zn	160x160/M27x250
930180031	PÄTKA S PEV. DOS. +DLHÁ MATICA	S	Zn	100x100/120-180/M20

PÄTKA S VOLNOU DOSKOU VÝŠKOVO NASTAVITELNÁ



Artik. číslo	Názov	Materiál	Povrch. úprava	Rozmer dosky / rozmer kolíka
930180012	PÄTKA S VOLNOU DOSKOU	S	Zn	80x80/M16x160
930180013	PÄTKA S VOLNOU DOSKOU	S	Zn	80x80/M20x200
930180015	PÄTKA S VOLNOU DOSKOU	S	Zn	80x80/M24x250
930180021	PÄTKA S VOLNOU DOSKOU	S	Zn	110x110/M24x200
930180022	PÄTKA S VOLNOU DOSKOU	S	Zn	110x110/M24x250

PÄTKA "U" 2D VÝŠKOVO NASTAVITELNÁ



Artik. číslo	Názov	Materiál	Povrch. úprava	Rozmer dosky / rozmer kolíka
930180160	PÄTKA "U" 2D NASTAVITELNÁ	S	Zn	80x80-160x120/120-180/M20

HROT KOTVIACI -DO ZEME



Artik. číslo	Názov	Materiál	Povrch. úprava	Rozmer - hrúbka
930180311	HROT KOTVIACI ŠTVORCOVÝ	S	Zn	50x50x150x600-2
930180312	HROT KOTVIACI ŠTVORCOVÝ	S	Zn	70x70x150x750-2
930180313	HROT KOTVIACI ŠTVORCOVÝ	S	Zn	90x90x150x750-2
930180314	HROT KOTVIACI ŠTVORCOVÝ	S	Zn	100x100x150x900-2
930180315	HROT KOTVIACI ŠTVORCOVÝ	S	Zn	120x120x150x900-2
930180301	HROT KOTVIACI VALCOVÝ	S	Zn	ø80x150x750-2
930180302	HROT KOTVIACI VALCOVÝ	S	Zn	ø100x150x750-2
930180303	HROT KOTVIACI VALCOVÝ	S	Zn	ø120x150x900-2



VRUT - TANIEROVÁ HLAVA 8x80 - 300 (mm)

INFORMAČNÉ SAMOLEPKY A PLASTOVÉ TABULE



Typ	šírka	výška
Samolepiaca fólia	105	37



Typ	šírka	výška
Samolepiaca fólia	148	210



Typ	šírka	výška
Samolepiaca fólia	150	100



Typ	šírka	výška
Samolepiaca fólia	150	150



Typ	šírka	výška
Samolepiaca fólia	150	50



Typ	šírka	výška
Samolepiaca fólia	150	75



Typ	šírka	výška
Samolepiaca fólia	105	37



Typ	šírka	výška
Samolepiaca fólia	80	150



Typ	šírka	výška
Samolepiaca fólia	210	80



Typ	šírka	výška
Samolepiaca fólia	52	74



Typ	šírka	výška
Plast	210	297



Typ	šírka	výška
Plast	210	297



Typ	šírka	výška
Samolepiaca fólia	210	297



Typ	šírka	výška
Plast	210	297



Typ	šírka	výška
Plast	210	297



Typ	šírka	výška
Plast	210	297



Typ	šírka	výška
Plast	210	297



Typ	šírka	výška
Samolepiaca fólia	148	210



Typ	šírka	výška
Samolepiaca fólia	297	210



Typ	šírka	výška
Plast	297	210



Typ	šírka	výška
Plast	297	210



Typ	šírka	výška
Plast	210	297



Typ	šírka	výška
Samolepiaca fólia	210	297



Typ	šírka	výška
Plast	210	297



Typ	šírka	výška
Samolepiaca fólia	210	148



Typ	šírka	výška
Plast	297	210



Typ	šírka	výška
Plast	297	210

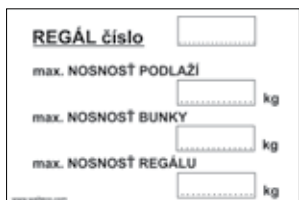

Typ	šírka	výška
Samolepiaca fólia	150	100

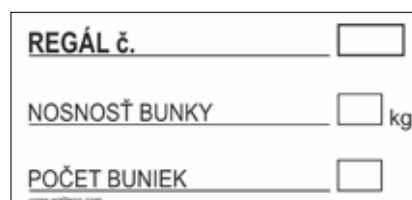

Typ	šírka	výška
Samolepiaca fólia	95	45



Typ	šírka	výška
Samolepiaca fólia	210	148



Typ	šírka	výška
Samolepiaca fólia	210	297



Typ	šírka	výška
Plast	210	297



Typ	šírka	výška
Plast	210	297



Typ	šírka	výška
Samolepiaca fólia	210	297



Typ	šírka	výška
Plast	297	210
Plast	210	148



Typ	šírka	výška
Samolepiaca fólia inverzná	210	148

OTVORENÉ
ZATVORENÉ

Typ	šírka	výška
Plast	300	100

HLAVNÝ UZÁVER
PLYNU

Typ	šírka	výška
Samolepiaca fólia	210	80

HLAVNÝ UZÁVER
VODY

Typ	šírka	výška
Samolepiaca fólia	210	80

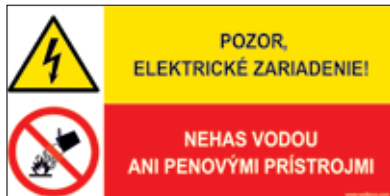

Typ	šírka	výška
Samolepiaca fólia	150	75
Samolepiaca fólia	75	50



Typ	šírka	výška
Plast	210	148



Typ	šírka	výška
Samolepiaca fólia	105	150



Typ	šírka	výška
Samolepiaca fólia	290	100



Typ	šírka	výška
Samolepiaca fólia	290	100



Typ	šírka	výška
Samolepiaca fólia	290	100



Typ	šírka	výška
Samolepiaca fólia	105	74



Typ	šírka	výška
Plast	210	148



Typ	šírka	výška
Samolepiaca fólia	210	148

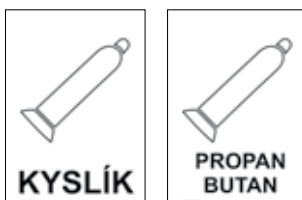

Typ	šírka	výška
Samolepiaca fólia	148	210

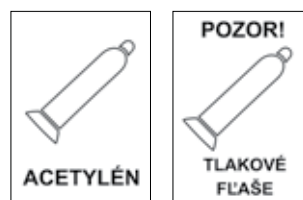

Typ	šírka	výška
Samolepiaca fólia	148	210



Typ	šírka	výška
Samolepiaca fólia	210	148



Typ	šírka	výška
Samolepiaca fólia	210	148



Typ	šírka	výška
Plast	297	210



Typ	šírka	výška
Plast	210	148



www.knkplus.sk

marketing@knkplus.sk

trade@knkplus.sk

+421 917 979 003

+421 484 142 583

Obchodný zástupca *(západné a stredné Slovensko)*

tel.: +421 918 182 367

Obchodný zástupca *(východné Slovensko)*

tel.: +421 917 334 872